



Frictional Connections

Product Catalogue



Certified to
DIN ISO 9001:2015

STÜWE®

STÜWE[®]

Frictional connections –

Equipment that connects

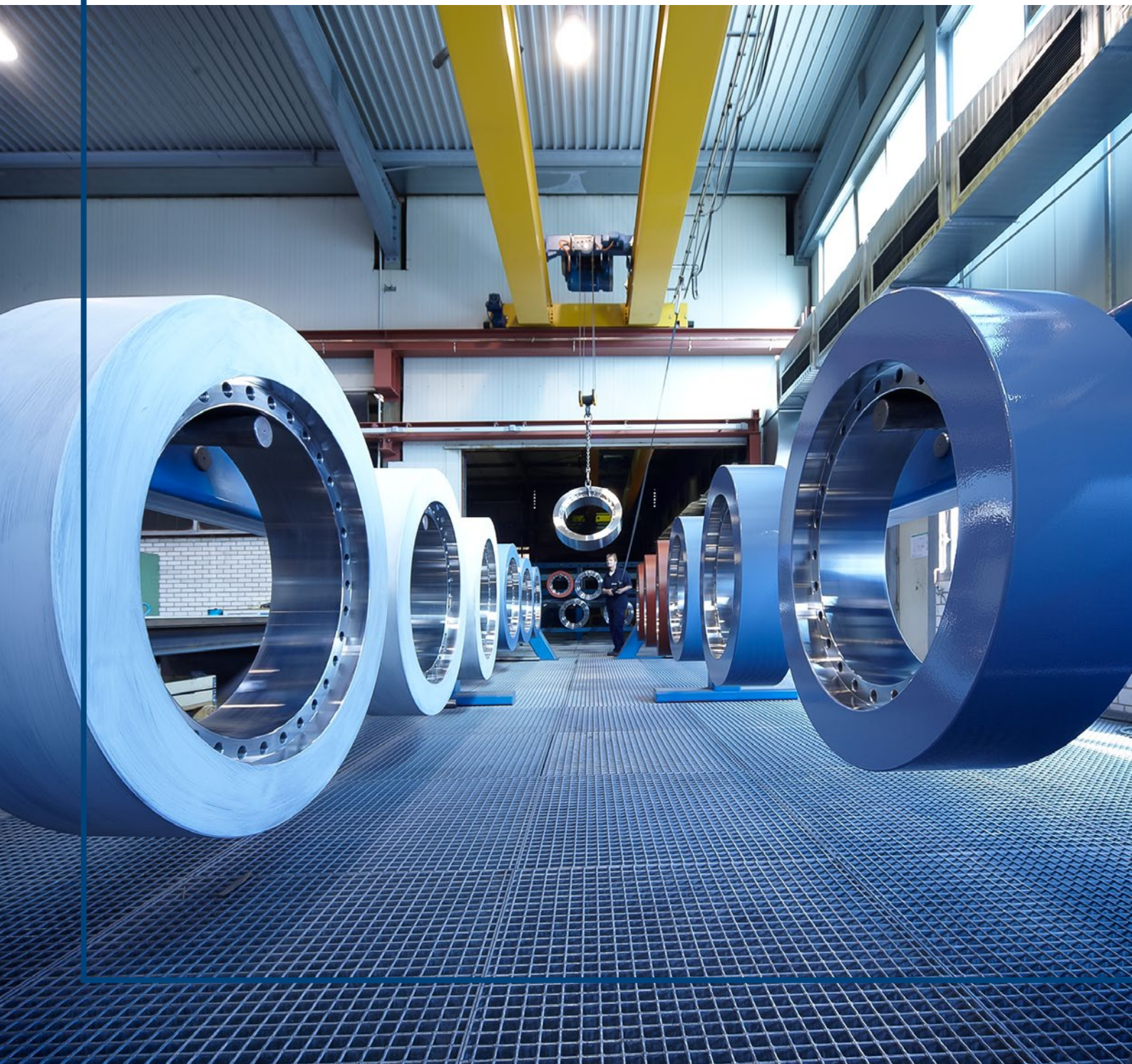

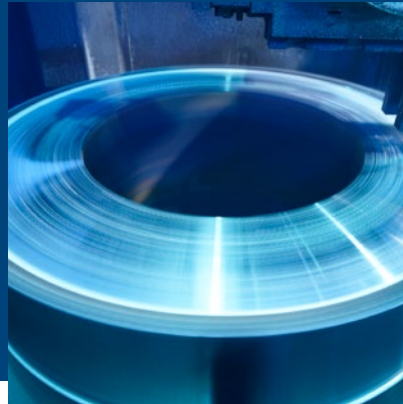

High Performance

- Safe transmission at torques of up to 18 000 000 Nm
- Suited for shaft diameters from 8 mm up to over 1000 mm
- Quick and easy, space-saving installation and non-destructive removal
- No frictional corrosion
- Compact design
- Normal surface qualities of shafts & hubs
- May be used as an application-related assembly
- May be fastened using bolts or hydraulic systems

The Benefits

STÜWE® frictional connections can be easily and non-destructively installed and removed – unlike friction-type connections which are joined either thermally or by other means. The clearance fits between a shaft and hub or between a hub and a “STÜWE® disc” enable easy installation and removal. Renowned companies throughout the world appreciate the benefits of our products.

Certified Quality

You are guaranteed a top-class service from us not only through our highly-qualified employees but also due to our state-of-the-art production facilities and consistent optimisation of our operating processes.

As an ISO 9001-certified company, we have everything under control, from the goods-inwards inspection of our materials up to the final inspection of our precision products. The latest inspection procedures and, not least, great care guarantee you a consistently high level of quality, safety and service life for each and every frictional connection. On request all STÜWE® products may be supplied with marine classification inspection.

Company Description

STÜWE® GmbH & Co. KG, located in Hattingen in the Ruhr district of Germany, is a globally leading manufacturer of frictional shaft-hub connections. We develop and produce top-quality, highly specialised frictional connections for especially demanding applications. Renowned companies throughout the world appreciate the benefits of our products and have placed their trust for many years in our expertise and the long service life of our products. That binds us in our common goals. Shrink discs, locking units, shaft couplings, flange couplings, cardan shaft couplings and special customised products form just a fraction of our company’s comprehensive product portfolio.

Benefit today from powerfully-driven equipment that is Made in Germany.

STÜWE[®]

Contents



General information	P. 06
Product Overview	P. 06
Areas of Application	P. 08
Technical Specification	P. 09

(Two-part) Shrink Disc Type HSD – mechanical	P. 14
General information	P. 15
Series	P. 16
Special solutions	P. 39

(Three-part) Shrink Disc Type SD	P. 42
General information	P. 43
Series	P. 44
Special solutions	P. 49

Shrink Disc Type HYD – hydraulic	P. 52
General information	P. 53
Series	P. 54
Special solutions	P. 60

Shrink Disc Type SDG, SDGH	P. 62
General information	P. 63
Series	P. 64
Special solutions	P. 73

External Locking Unit Type AS	P. 74
General information	P. 75
Series	P. 76
Special solutions	P. 85

Shaft Coupling Type WK, WKL	P. 88
General information	P. 89
Series	P. 90
Special solutions	P. 97

Flange Coupling Type FKH, FKHA, FKD – mechanical	P. 102
General information	P. 103
Series	P. 104
Special solutions	P. 109

Flange Coupling Type FKHYD – hydraulic	P. 118
General information	P. 119
Series	P. 120
Special solutions	P. 123

Cardan Shaft Connecting Flange Type GF	P. 124
General information	P. 125
Series	P. 126
Special solutions	P. 131

Internal Locking Unit Type IS	P. 134
General information	P. 135
Series	P. 136
Special solutions	P. 149

Services (Engineering, Job Order Production, ...)	P. 151
--	---------------



General information

Product Overview

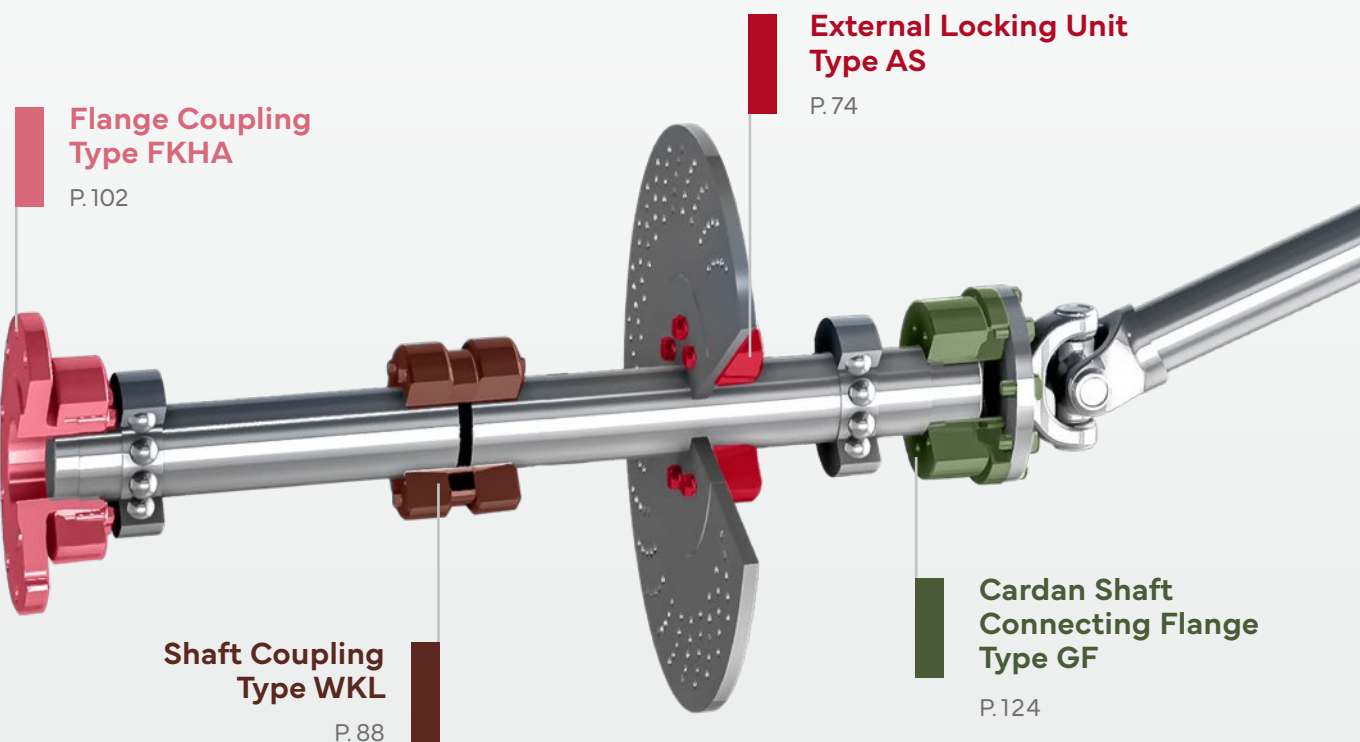

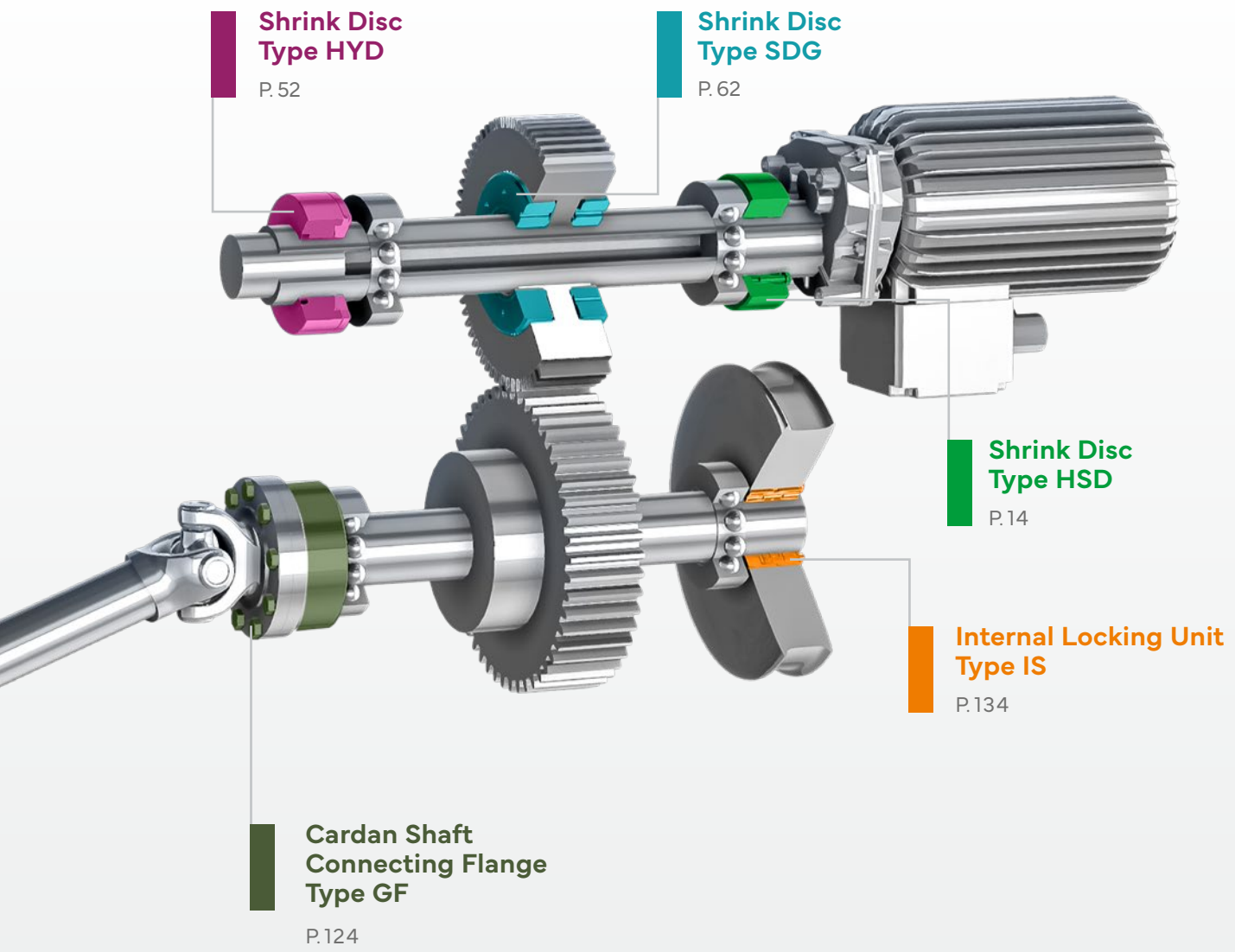

**Shrink Disc
Type HYD**

P. 52

**Shrink Disc
Type SDG**

P. 62

**Shrink Disc
Type HSD**

P. 14

**Internal Locking Unit
Type IS**

P. 134

**Cardan Shaft
Connecting Flange
Type GF**

P. 124

General information

Areas of Application

STÜWE® frictional connections are versatile in their use. They can be used in practically all powertrains and in many other applications. The individual sizes range from just a few mm up to more than 1000 mm, with transmission torques of a few Nm up to more than 18 000 000 Nm.

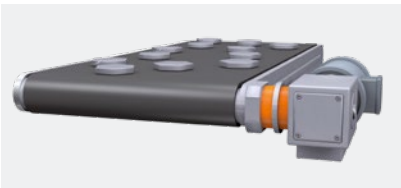

Belt drives

- Flange coupling for the connection of a gear motor with a drive shaft

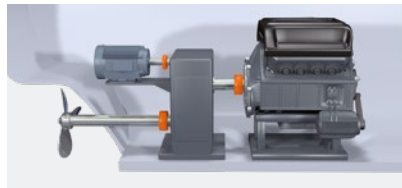

- Locking units for main engine couplings and shaft couplings in marine drives



Crushing equipment

- A shock-resistant connection between the motor and rollers in crushing equipment

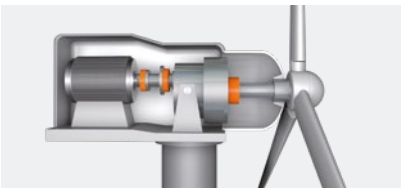

Wind turbines

- Shaft-hub connection on the slow and quick sides in wind turbines



Rolling mill equipment

- Suited for alternating torques and impact loading in reversing operation of a rolling mill

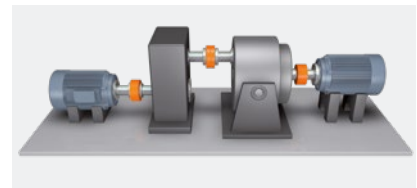

Test beds

- Possible applications in test bed equipment, also with hydraulic tensioning

Further areas of use:

- Fixing of brake discs
- Fixing of slip-on gears to a shaft
- Fixing of couplings in such as printing presses, agitators
- Axial fixing of mechanical seals
- Fixing of paddle wheels in tailings facilities
- Fixing of water wheels
- Fixing of flywheels
- Fixing of shafts in such as weaving machines or other precision mechanics applications

General information

Technical Specifications

$$\left(\frac{d_w \cdot P_{ax}}{2} \right)^2$$

Maximum transmissible torque M_t

The transmissible torque or the transmissible axial load is dependent on the coefficient of friction in the compression joint transmitting the load, the fitting tolerance, the clamping length and the shaft diameter. The catalogue value is based on an assumed coefficient of friction, the maximum possible fitting tolerance and $P_{ax} = 0$ for a given shaft diameter and for a solid shaft.

Coefficient of friction

The coefficient of friction of dry and grease free surface (steel/steel) ranges from 0.15 to 0.33. The transmissible torques of the external locking STÜWE® discs are calculated using a value of $\mu_w = 0.15$.

Calculations may be made using higher coefficients of friction where there is special surface treatment. In addition, the surfaces must be carefully de-greased. Coefficients of friction of about $\mu_w = 0.2$ are achieved. The transmissible torque can thus be increased accordingly.

Fit clearance

The torque calculation takes into account the maximum fitting tolerance and surface roughness. If the actual fitting tolerance is tighter, then the transmissible torque consequently increases. On the other

hand, the transmissible torque reduces if the fitting tolerance is larger than that given in the catalogue.

Shaft diameter

The shaft diameter range for every frictional connection is specified in the product tables. If a shaft diameter is selected which is between two given values, the transmissible torque may then be found with sufficient accuracy by interpolation. (Larger shaft diameters can be chosen if hub material permits. The transmissible torques can be extrapolated.

Axial load „ P_{ax} “

The maximum transmissible axial load (for $M_t = 0$ Nm) may be calculated from the maximum transmissible torque (for $P_{ax} = 0$ kN):

$$P_{ax, max} = M_{t, list} \cdot \frac{2}{d_w}$$

Transmission of torque combined with axial load

If torsional and axial loads are to be transmitted simultaneously, use the following equation:

$$M_t'' = \sqrt{M_{t, list}^2 - \left(\frac{d_w \cdot P_{ax}}{2} \right)^2}$$

M_t'' is the torque reduced by axial load P_{ax} .

General information

Technical Specifications

Hub material

Steel, cast steel or nodular cast iron with a yield strength of at least 360 N/mm² can be used as material for a hub. On assemblies which also have to transmit also bending moments (rotating bending) the hub should be of heat-treatable steel like 42CrMo4 or higher quality cast steel or nodular cast iron.

Grey cast iron can be used for assemblies where negligible bending moments occur. The hub thickness must be selected to be greater than normal in such cases.

Material

All frictional connections are offered in 42CrMo4 as standard. In

addition, our products are available in 1.4122 and in 1.4462. It must be noted that in these cases other torques may be transmitted. Depending on the combination of materials, an inspection by our Design department will be necessary.

Surface quality

The surface roughness (Rt) of the shaft and hub should be below 16 µm (turning on a lathe is sufficient).

Lubricant

Conical surfaces are greased with a MoS₂ lubricant (a combination of bonding coating and paste). The locking bolts are lubricated with bolt lubricants ($\mu=0.1$).

Locking bolts

All units are equipped with commercial available hexagonal bolts DIN EN ISO 4014/4017, quality 10.9 or 12.9. More exact specifications may be found in each of the tables for a particular type.

Alternatively, hexagonal socket head bolts to DIN EN ISO 4762 may also be used and ordered.

From a locking bolt size of M16 upwards high-strength washers are additionally used.

General information

Arrangement and Calculation

(Two-part) Shrink Disc Type HSD – Mechanical

When tensioning the shrink disc, multidirectional stresses occur in the hub. Tangential and radial stress can be calculated by using the following equation for the thick-walled pipes (axial stress can be neglected). Maximum stress occurs on the internal fibre of a hub

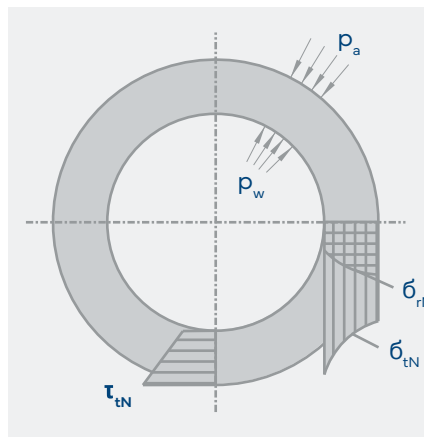

$$\sigma_t = \frac{p_w \left(1 + \left(\frac{d_w}{d} \right)^2 \right) - 2 \cdot p_a}{1 - \left(\frac{d_w}{d} \right)^2}$$

$$\sigma_r = -p_w$$

Comparative stress can be calculated using the maximum distortion energy theory:

$$\sigma_v = \sqrt{\sigma_t^2 + \sigma_r^2 - \sigma_t \cdot \sigma_r + 3\tau^2}$$

Pressure p_w determined by means of equation (with the maximum transmissible torque M_t).

$$p_w = \frac{2 \cdot M_t}{\pi \cdot d_w^2 \cdot l \cdot \mu_w}$$

General information

Arrangement and Calculation

Internal Locking Unit Type IS

The hubs are expanded due to the pressure of the locking units. So that no plastic deformation occurs as a result of the expansion, the external diameter of the hub D_N must be selected to be of a sufficiently large size. The following conditional equation derived from the equation for thick-walled pipes under internal pressure can be used to calculate the outside diameter with sufficient accuracy:

$$D_N \geq D \cdot \sqrt{\frac{\sigma_{0.2N} + p_N \cdot C}{\sigma_{0.2N} - p_N \cdot C}}$$

Whereby

- $\sigma_{0.2N}$ Yield strengths of the hub
- p_N hub bore pressure
- C is a factor which takes into account the width of the hub over the locking unit
- $C = 1$ for hubs which are as wide as the locking unit
- $C = 0.6$ for hubs which are twice as wide as the locking unit

Regardless of the hub width, the yield strength of the hub material should always be higher than the applied pressure p_N .

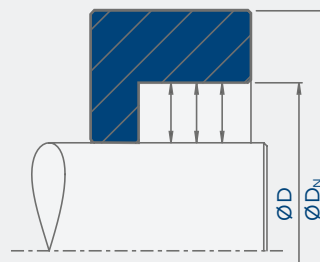

When type IS locking units are used in hollow shafts, the following format which can be derived from the equations for thick-walled tubes may be used for the determination of the maximum permissible drill hole size d_i in a hollow shaft:

$$d_i \leq d \cdot \sqrt{\frac{\sigma_{0.2S} - 2 \cdot p_s \cdot C}{\sigma_{0.2S}}}$$

The hole diameter d_i can be increased by the use of a supporting sleeve.

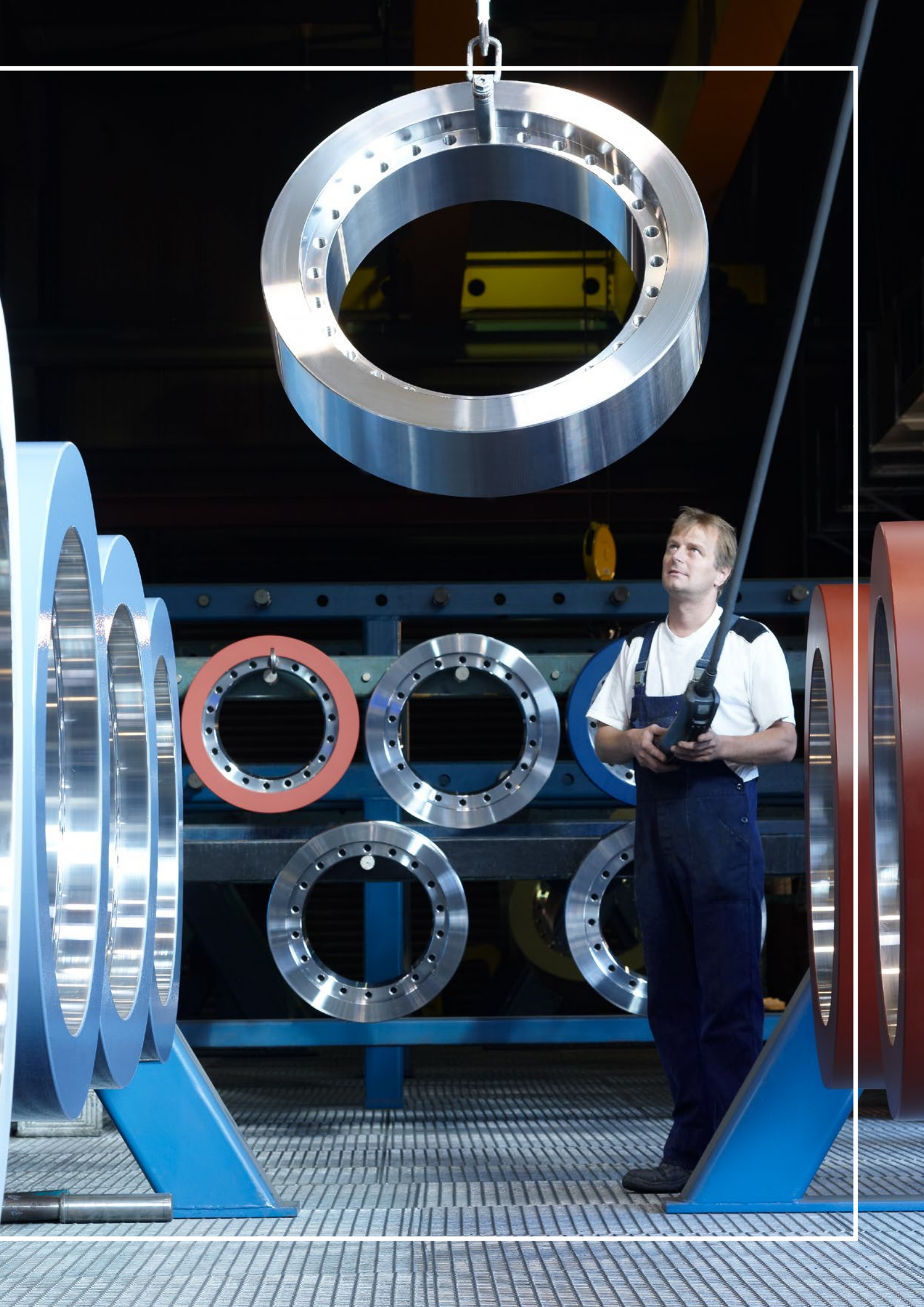

STÜWE[®]



Shrink Disc

Type HSD – Mechanical



Shrink Disc Type HSD

General Information

Application Description

Shrink discs are detachable machine elements for the connection of a hub to a shaft. The two-part path-controlled frictional connection is maintenance-free and dirt-resistant due to its press fit and is very versatile in its use. The cost-effective and high-quality mechanical shrink discs are supplied by STÜWE® in many different variants.

Areas of Use



Driveline technology



Steel- & rolling mill equipment



Crushing equipment

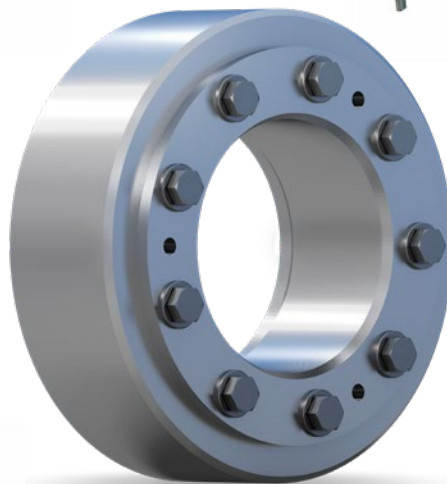

Conveying equipment



Agitation & mixing equipment



Wind turbines

Shrink Disc

Type HSD – Series

Description	Shaft diameter	Transmissible torque	Features
HSD 20	20 - 250 mm	0.15 - 18.3 kNm	Low torques
HSD 21	110 - 730 mm	16 - 4033 kNm	Average torques
HSD 22	9 -1050 mm	0.02 -16493 kNm	High torques
HSD 23	100 -1050 mm	26 -19684 kNm	Very high torques
HSD 81	38 -1050 mm	1.5 -19958 kNm	As series 22 but with 20 - 30 % higher torque capacity
HSD 83	100 -1050 mm	30 - 23811 kNm	As series 23 but with 20 - 30 % higher torque capacity
HSD 20 - 1.4122	20 - 250 mm	0.08 - 9.14 kNm	Low torques, rust-and acid-proof
HSD 20 - 1.4462	20 - 250 mm	0.06 - 6.84 kNm	Low torques, rust-and acid-proof

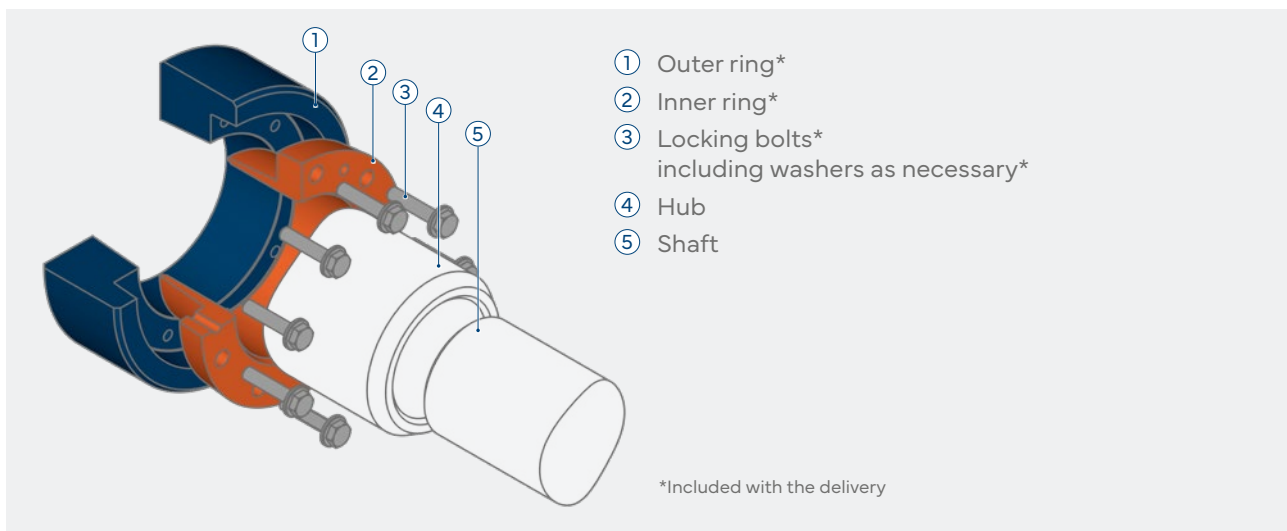

All types may be protected against environmental influences by zinc and nickel coating or by a paint which has an appropriate corrosion protection class. We are able to achieve both desired colours which conform with the RAL colour range and products with lubricants in accordance with NSF H1. More detailed information on this may be found in this catalogue on page 151.

Shrink Disc Type HSD Series 20

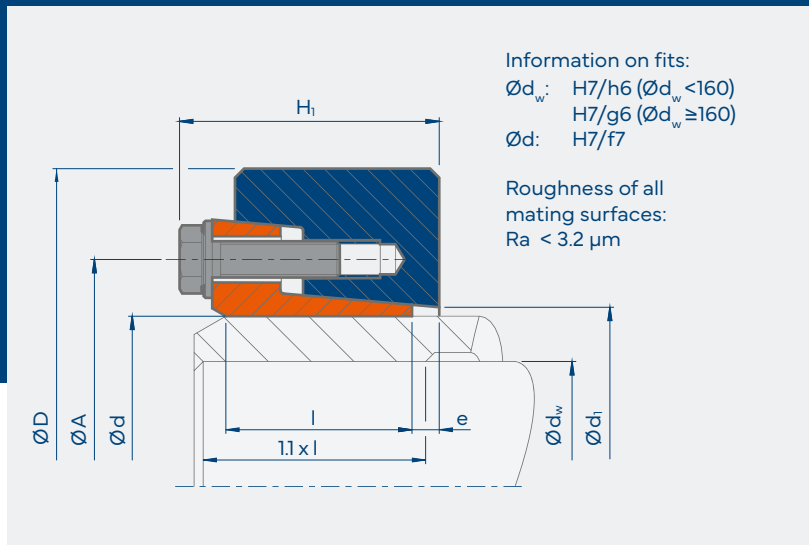

Code

- M_t Maximum transmissible torque of a shrink disc for $P_{ax} = 0$
- P_{ax} Maximum transmissible axial load of a shrink disc for $M_t = 0$
- M_a Required tightening torque of the locking bolts (see also "Installation and Removal Instructions")

Dimensions H_1 and e apply to untightened units.

Shrink Disc Type HSD – Series 20

Type	d mm	d_w mm	M_t kNm	P_{ax} kN	M_a Nm	B*	D mm	l mm	H_1 mm	A mm	d_1 mm	e mm	kg
HSD 24 - 20	24	20	0.15	15	12	6 x M6	50	11.5	17	38	25.5	1.5	0.2
		21	0.17	17									
		22	0.21	19									
HSD 29 - 20	29	25	0.22	18	12	6 x M6	58	12.5	18	44	32	1.5	0.2
		26	0.25	19									
		27	0.29	21									
HSD 35 - 20	34	29	0.22	15	12	5 x M6	64	12.5	18	52	39	1.5	0.2
		35	0.25	16									
		32	0.31	19									
HSD 40 - 20	38	34	0.28	16	12	6 x M6	69	12.2	18	55	43	1.6	0.3
		40	0.31	18									
		36	0.34	19									
HSD 46 - 20	46	38	0.41	22	12	6 x M6	80	13	23	62	49	2.5	0.4
		47	0.50	25									
		42	0.60	28									
HSD 51 - 20	51	44	0.55	25	12	8 x M6	86	13	23	67	54	2.6	0.5
		45	0.60	27									
		47	0.70	30									
HSD 56 - 20	55	48	0.57	24	12	8 x M6	90	13	23	72	59	3	0.5
		56	0.66	26									
		57	0.76	29									
HSD 61 - 20	61	53	0.68	26	12	8 x M6	96	13	24	76	64	3	0.6
		55	0.79	29									
		57	0.90	32									
HSD 66 - 20	65	58	0.74	26	12	8 x M6	100	13	24	82	69	3	0.6
		66	0.85	28									
		62	0.97	31									

*Locking bolts: standard DIN EN ISO 4014/4017 Grade 10.9, alternative DIN EN ISO 4762 Grade 10.9
 M16 and upwards with washers: DIN EN ISO 7416

When ordering please state: (Type x $\text{Ø}d$) e.g. HSD 35 - 20 x 34

Shrink Disc Type HSD – Series 20

Type	d mm	d _w mm	M _t kNm	P _{ax} kN	M _a Nm	B*	D mm	l mm	H ₁ mm	A mm	d ₁ mm	e mm	kg
HSD 73 - 20	70	63	0.94	30	29	9 x M8	115	18	30	94	77	3	1.2
	72	65	1.07	33									
	73	68	1.29	38									
HSD 78 - 20	76	68	1.21	36	29	9 x M8	120	18	30	100	82	3	1.2
	78	70	1.36	39									
		72	1.52	42									
HSD 83 - 20	81	73	1.24	34	29	9 x M8	125	18	30	104	87	3	1.3
	83	75	1.38	37									
		77	1.54	40									
HSD 88 - 20	86	78	1.47	38	29	9 x M8	130	18	30	110	92	3	1.4
	88	80	1.62	40									
		82	1.78	43									
HSD 93 - 20	93	83	1.63	39	29	9 x M8	135	18	31	114	97	3	1.4
	94	85	1.80	42									
		87	1.97	45									
HSD 98 - 20	96	88	1.72	39	29	9 x M8	140	18	31	120	102	3	1.5
	98	90	1.89	42									
		92	2.07	45									
HSD 103 - 20	103	93	2.13	46	29	10 x M8	145	18	31	124	107	3.5	1.5
		95	2.31	49									
		97	2.50	52									
HSD 108 - 20	106	98	2.16	44	29	10 x M8	150	18	31	128	112	3.5	1.6
	108	100	2.34	47									
		102	2.53	50									
HSD 115 - 20	112	103	2.34	45	29	10 x M8	160	22	35	134	118	3.5	2.1
	115	105	2.54	48									
		108	2.86	53									
HSD 120 - 20	118	108	2.82	52	29	10 x M8	164	22	35	140	124	3.5	2.1
	120	110	3.03	55									
		113	3.37	60									
HSD 125 - 20	125	113	2.94	52	29	12 x M8	169	22	35	144	129	3.5	2.2
		115	3.16	55									
		118	3.49	59									
HSD 130 - 20	130	118	3.15	53	29	12 x M8	174	22	35	150	134	3.5	2.2
		120	3.37	56									
		123	3.71	60									
HSD 135 - 20	135	123	3.57	58	29	12 x M8	179	22	35	154	139	3.5	2.3
		125	3.81	61									
		128	4.19	66									
HSD 140 - 20	138	128	3.93	61	29	12 x M8	184	22	36	160	144	4	2.4
	140	130	4.18	64									
		132	4.44	67									
HSD 145 - 20	145	133	4.39	66	29	12 x M8	189	22	36	164	149	4	2.5
		135	4.65	69									
		137	4.92	72									
HSD 150 - 20	150	138	4.89	71	29	12 x M8	194	22	36	170	154	4	2.5
		140	5.16	74									
		142	5.44	77									
HSD 160 - 20	160	146	4.86	67	29	12 x M8	204	22	35	180	164	4	2.6
		150	5.39	72									
		152	5.67	75									
HSD 170 - 20	166	156	5.20	67	29	12 x M8	214	22	35	190	174	4	3.0
	170	160	5.73	72									
		162	6.01	74									

*Locking bolts: standard DIN EN ISO 4014/4017 Grade 10.9, alternative DIN EN ISO 4762 Grade 10.9
M16 and upwards with washers: DIN EN ISO 7416

When ordering please state: (Type x Ød) e.g. HSD 108 - 20 x 106

Shrink Disc Type HSD – Series 20

Type	d mm	d _w mm	M _t kNm	P _{ax} kN	M _a Nm	B*	D mm	l mm	H ₁ mm	A mm	d ₁ mm	e mm	kg
HSD 182 - 20	182	166	7.62	92	29	14 x M8	230	25	41	206	188	5	3.9
		170	8.35	98									
		172	8.73	101									
HSD 192 - 20	189	176	8.35	95	29	14 x M8	240	25	41	216	198	5	3.9
		192	9.09	101									
		182	9.47	104									
HSD 202 - 20	197	186	8.88	95	29	15 x M8	250	25	41	224	208	5.5	4.6
		198	9.67	102									
		202	10.08	105									
HSD 212 - 20	212	196	9.74	99	29	15 x M8	260	25	41	234	218	5.5	4.4
		200	10.55	106									
		202	10.97	109									
HSD 222 - 20	220	206	10.83	105	29	16 x M8	270	25	42	244	228	5.7	4.9
		222	11.66	111									
		212	12.09	114									
HSD 232 - 20	230	216	14.40	133	29	16 x M8	280	25	42	254	238	5.7	5.0
		232	15.35	140									
		222	15.83	143									
HSD 242 - 20	242	226	15.27	135	29	16 x M8	290	25	42	264	248	5.7	5.0
		230	16.22	141									
		232	16.72	144									
HSD 252 - 20	252	234	15.98	137	29	16 x M8	300	25	42	274	258	6	5.2
		238	16.94	142									
		240	17.44	145									
HSD 262 - 20	262	244	16.84	138	29	18 x M8	310	25	42	286	268	6	5.6
		248	17.80	144									
		250	18.30	146									

Further sizes on request, subject to technical changes.

*Locking bolts: standard DIN EN ISO 4014/4017 Grade 10.9, alternative DIN EN ISO 4762 Grade 10.9
M16 and upwards with washers: DIN EN ISO 7416

When ordering please state: (Type x Ød) e.g. HSD 192 - 20 x 192

Shrink Disc Type HSD Series 21

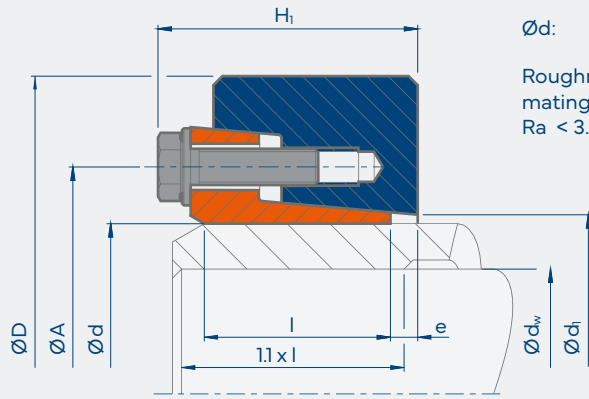

Information on fits:
 $\varnothing d_w$: H7/h6 ($\varnothing d_w < 160$)
 H7/g6 ($\varnothing d_w \geq 160$)
 $\varnothing d$: H7/f7

Roughness of all mating surfaces:
 $R_a < 3.2 \mu\text{m}$

Code

- Mt** Maximum transmissible torque of a shrink disc for $P_{ax} = 0$
- Pax** Maximum transmissible axial load of a shrink disc for $M_t = 0$
- Ma** Required tightening torque of the locking bolts (see also "Installation and Removal Instructions")

Dimensions H1 and e apply to untightened units.

Type	d mm	d _w mm	M _t kNm	P _{ax} kN	M _a Nm	B*	D mm	l mm	H ₁ mm	A mm	d ₁ mm	e mm	kg
HSD 140 - 21	140	110	16	298	100	9 x M12	215	38	52	164	143	6.5	6.4
		120	20	341									
		130	25	385									
HSD 155 - 21	155	130	26	398	100	15 x M12	245	38	52	184	164	6.5	8.7
		160	28	420									
		140	31	443									
HSD 165 - 21	165	135	29	432	160	12 x M14	263	43	58	200	174	6.2	11.4
		170	32	456									
		145	35	480									
HSD 175 - 21	175	145	36	497	160	12 x M14	275	43	59	208	184	7.2	12.2
		180	39	522									
		155	42	547									
HSD 185 - 21	185	155	50	645	160	16 x M14	290	51	68	220	195	8.2	16
		190	54	675									
		165	58	704									
HSD 195 - 21	195	165	68	822	160	15 x M14	320	51	68	230	204	8.2	20.6
		200	73	855									
		180	83	922									
HSD 220 - 21	220	180	80	892	240	16 x M16	340	55	79	254	227	10	23.6
		190	91	962									
		200	103	1032									
HSD 240 - 21	240	200	103	1026	240	16 x M16	370	55	80	274	247	11	27.6
		210	115	1095									
		220	128	1165									
HSD 260 - 21	260	220	132	1197	240	18 x M16	405	55	80	294	266	11	33.5
		230	146	1271									
		240	161	1344									
HSD 280 - 21	280	230	160	1392	470	15 x M20	430	65	93	320	288	12	44.1
		240	177	1473									
		250	194	1555									

*Locking bolts: standard DIN EN ISO 4014/4017 Grade 10.9, alternative DIN EN ISO 4762 Grade 10.9
 M16 and upwards with washers: DIN EN ISO 7416

When ordering please state: (Type x $\varnothing d$) e.g. HSD 185 - 21 x 190

Shrink Disc Type HSD – Series 21

Type	d mm	d _w mm	M _t kNm	P _{ax} kN	M _a Nm	B*	D mm	l mm	H ₁ mm	A mm	d ₁ mm	e mm	kg
HSD 300 - 21	300	250	191	1529	470	16 x M20	460	65	94	340	308	13	50.2
		260	209	1610									
		270	228	1691									
HSD 320 - 21	320	270	243	1804	470	20 x M20	485	77	106	364	327	13	64.5
		280	265	1894									
		290	288	1986									
HSD 340 - 21	340	280	274	1958	470	20 x M20	520	77	106	384	347	13	75
		290	297	2050									
		300	322	2143									
HSD 360 - 21	360	300	356	2373	470	20 x M20	570	89	122	410	368	13	113
		310	384	2476									
		330	443	2686									
HSD 390 - 21	390	330	438	2654	470	24 x M20	590	89	123	440	398	14	114
		340	469	2759									
		350	501	2865									
HSD 420 - 21	420	350	624	3564	820	18 x M24	630	120	160	470	427	21	166
		360	665	3697									
		370	709	3831									
HSD 440 - 21	440	370	778	4203	820	20 x M24	660	132	174	494	448	21	203
		380	826	4350									
		390	877	4497									
HSD 460 - 21	460	390	852	4370	820	20 x M24	690	132	174	516	468	21	222
		400	903	4514									
		410	955	4658									
HSD 480 - 21	480	410	1086	5298	820	24 x M24	720	152	194	540	487	23	274
		420	1147	5461									
		430	1210	5626									
HSD 500 - 21	500	420	1137	5415	820	24 x M24	745	152	197	560	508	24	293
		430	1200	5581									
		450	1331	5914									
HSD 530 - 21	530	450	1376	6114	1210	24 x M27	790	166	209	594	540	20	359
		460	1446	6287									
		480	1592	6635									
HSD 560 - 21	560	480	1578	6576	1210	28 x M27	830	166	211	626	570	22	393
		490	1653	6748									
		510	1809	7093									
HSD 590 - 21	590	510	1873	7344	1210	24 x M27	880	172	219	658	599	26	452
		520	1957	7526									
		540	2131	7891									
HSD 620 - 21	620	540	2097	7768	1210	24 x M27	930	172	222	690	629	28	516
		550	2186	7948									
		570	2368	8309									
HSD 660 - 21	660	570	2426	8511	1640	24 x M30	990	182	235	734	670	29	619
		580	2522	8696									
		610	2823	9255									
HSD 700 - 21	700	610	2772	9088	1640	24 x M30	1040	182	234	774	710	28	694
		620	2874	9271									
		640	3084	9638									
HSD 750 - 21	750	640	3104	9700	1640	28 x M30	1100	192	246	826	760	30	777
		650	3214	9888									
		680	3555	10456									
HSD 800 - 21	800	680	3443	10128	1640	28 x M30	1150	192	248	876	809	32	819
		700	3673	10495									
		730	4033	11049									

Further sizes on request, subject to technical changes.

*Locking bolts: standard DIN EN ISO 4014/4017 Grade 10.9, alternative DIN EN ISO 4762 Grade 10.9
M16 and upwards with washers: DIN EN ISO 7416

When ordering please state: (Type x Ød) e.g. HSD 660 - 21 x 660

Shrink Disc Type HSD Series 22

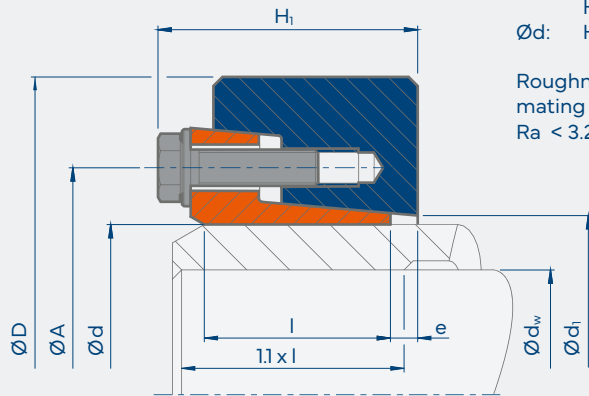

Information on fits:
 $\varnothing d_w$: H7/h6 ($\varnothing d_w < 160$)
 H7/g6 ($\varnothing d_w \geq 160$)
 $\varnothing d$: H7/f7

Roughness of all mating surfaces:
 $R_a < 3.2 \mu\text{m}$

Code

- M_t Maximum transmissible torque of a shrink disc for $P_{ax} = 0$
- P_{ax} Maximum transmissible axial load of a shrink disc for $M_t = 0$
- M_a Required tightening torque of the locking bolts (see also "Installation and Removal Instructions")

Dimensions H_1 and e apply to untightened units.

Type	d mm	d _w mm	M _t kNm	P _{ax} kN	M _a Nm	B*	D mm	l mm	H ₁ mm	A mm	d ₁ mm	e mm	kg
HSD 12 - 22	12	9	0.02	5	12	3 x M6	35	10	16	24	13	2	0.1
		10	0.04	8									
HSD 14 - 22	14	11	0.03	6	12	3 x M6	38	10	16	26	15	2	0.1
		12	0.05	9									
HSD 16 - 22	16	13	0.07	10	12	3 x M6	41	13.5	20	28	17	2.5	0.1
		14	0.09	13									
HSD 18 - 22	18	15	0.08	11	12	4 x M6	44	13.5	20	30	19	2.5	0.1
		16	0.11	14									
HSD 20 - 22	20	17	0.15	18	12	4 x M6	47	13.5	20	32	21	2.5	0.2
		18	0.18	20									
HSD 24 - 22	24	19	0.16	17	12	5 x M6	50	14	23	36	26	2.5	0.2
		20	0.20	20									
		22	0.28	25									
HSD 30 - 22	30	24	0.27	23	12	6 x M6	60	16	26	44	32	3	0.4
		25	0.32	25									
		26	0.36	28									
HSD 36 - 22	36	28	0.49	35	29	5 x M8	72	18	29	52	38	3.4	0.5
		30	0.61	41									
		33	0.82	50									
HSD 44 - 22	44	34	0.69	41	29	6 x M8	80	20	33	61	47	4.7	0.7
		35	0.77	44									
		36	0.84	47									

*Locking bolts: standard DIN EN ISO 4014/4017 Grade 10.9, alternative DIN EN ISO 4762 Grade 10.9
 M16 and upwards with washers: DIN EN ISO 7416

When ordering please state: (Type x Ød) e.g. HSD 44 - 22 x 42

Shrink Disc Type HSD – Series 22

Type	d mm	d _w mm	M _t kNm	P _{ax} kN	M _a Nm	B*	D mm	l mm	H ₁ mm	A mm	d ₁ mm	e mm	kg
HSD 50 - 22	50	38	1.10	58	29	8 x M8	90	22	34	68	53	4.4	0.9
		40	1.29	65									
		42	1.50	71									
HSD 55 - 22	55	42	1.23	59	29	8 x M8	100	23	36	72	58	4.4	1.2
		45	1.53	68									
		48	1.86	78									
HSD 62 - 22	62	48	1.67	70	29	9 x M8	110	23	36	80	66	4.4	1.4
		60	1.89	76									
		52	2.12	81									
HSD 68 - 22	68	50	1.87	75	29	9 x M8	115	23	36	86	72	4.4	1.4
		55	2.45	89									
		60	3.12	104									
HSD 75 - 22	75	55	2.33	85	58	10 x M10	138	25	40	100	79	4.6	2.5
		60	3.02	101									
		65	3.80	117									
HSD 80 - 22	80	60	3.19	106	58	10 x M10	141	25	40	104	84	4.6	2.5
		65	4.00	123									
		70	4.90	140									
HSD 90 - 22	90	65	5.4	166	58	10 x M10	155	30	46	114	94	5.1	3.5
		85	6.5	187									
		75	7.8	208									
HSD 100 - 22	100	70	6.0	171	58	12 x M10	170	34	51	124	104	5.1	4.7
		95	7.2	192									
		80	8.5	213									
HSD 110 - 22	110	80	10.0	249	100	12 x M12	185	39	59	137	114	5.5	6.3
		105	11.7	275									
		90	13.6	302									
HSD 120 - 22	120	85	11.9	280	100	12 x M12	197	42	63	147	124	6.5	7.4
		115	13.8	307									
		95	15.9	334									
HSD 125 - 22	125	90	14.4	319	100	12 x M12	215	42	63	152	129	6.5	9.3
		95	16.5	347									
		100	18.7	375									
HSD 135 - 22	135	95	18.1	382	160	10 x M14	230	46	69	165	139	7.2	11.5
		130	20.6	412									
		110	26.0	473									
HSD 140 - 22	140	100	19.6	392	160	12 x M14	230	46	70	172	146	8.2	11.1
		105	22.1	421									
		115	27.6	481									
HSD 155 - 22	155	110	26.5	482	160	12 x M14	263	50	74	186	159	8.7	15.9
		150	29.5	514									
		125	36.1	578									
HSD 165 - 22	165	120	37.3	622	240	12 x M16	290	56	85	198	169	9	22.2
		160	41.2	659									
		135	49.6	734									
HSD 175 - 22	175	130	45	692	240	12 x M16	300	56	85	208	179	9	23.3
		170	49	730									
		145	58	805									
HSD 185 - 22	185	140	64	916	240	16 x M16	320	71	102	222	191	10	33.3
		180	70	961									
		155	82	1053									
HSD 200 - 22	200	150	80	1073	240	16 x M16	340	71	102	238	206	10	36.9
		195	87	1120									
		190	100	1216									

*Locking bolts: standard DIN EN ISO 4014/4017 Grade 10.9, alternative DIN EN ISO 4762 Grade 10.9
M16 and upwards with washers: DIN EN ISO 7416

When ordering please state: (Type x Ød) e.g. HSD 200 - 22 x 195

Shrink Disc Type HSD – Series 22

Type	d mm	d _w mm	M _t kNm	P _{ax} kN	M _a Nm	B*	D mm	l mm	H ₁ mm	A mm	d ₁ mm	e mm	kg
HSD 220 - 22	220	160	103	1283	470	15 x M20	370	93	121	270	230	12	51.5
		170	119	1395									
		180	136	1509									
HSD 240 - 22	240	170	122	1439	470	16 x M20	405	95	124	288	248	12	63.9
		180	140	1555									
		200	179	1790									
HSD 260 - 22	260	190	163	1715	470	15 x M20	430	105	136	306	268	14	77.5
		200	184	1842									
		220	231	2099									
HSD 280 - 22	280	210	215	2051	470	16 x M20	460	114	146	328	288	16	94.7
		220	240	2186									
		240	295	2458									
HSD 300 - 22	300	220	270	2456	820	16 x M24	485	123	158	354	309	16	112
		230	300	2605									
		250	363	2906									
HSD 320 - 22	320	240	301	2511	820	18 x M24	520	125	159	380	328	14	133
		250	332	2655									
		270	398	2945									
HSD 340 - 22	340	250	390	3118	820	18 x M24	570	134	171	402	349	16	177
		260	427	3283									
		280	506	3617									
HSD 350 - 22	350	270	493	3649	820	20 x M24	580	140	178	414	365	16	190
		280	535	3825									
		290	580	4001									
HSD 360 - 22	360	270	496	3676	820	20 x M24	590	140	179	416	369	17	194
		280	539	3852									
		300	631	4206									
HSD 380 - 22	380	290	585	4034	1210	18 x M27	640	146	188	444	388	19	244
		300	632	4215									
		310	681	4397									
HSD 390 - 22	390	290	640	4411	1210	18 x M27	645	146	189	454	398	20	243
		300	691	4605									
		320	799	4996									
HSD 420 - 22	420	320	742	4640	1210	18 x M27	670	167	210	490	428	20	286
		330	797	4829									
		350	912	5209									
HSD 440 - 22	440	340	945	5557	1210	21 x M27	710	174	219	506	448	22	339
		350	1009	5764									
		370	1143	6181									
HSD 460 - 22	460	360	1104	6133	1210	21 x M27	745	174	222	534	470	25	375
		370	1174	6345									
		390	1320	6771									
HSD 480 - 22	480	380	1300	6843	1640	20 x M30	770	192	239	552	488	22	437
		390	1378	7066									
		410	1541	7516									
HSD 500 - 22	500	400	1496	7478	1640	21 x M30	800	192	241	572	509	24	470
		410	1581	7711									
		430	1759	8180									
HSD 530 - 22	530	430	1930	8976	1640	24 x M30	845	213	266	606	540	29	576
		440	2031	9234									
		460	2243	9752									
HSD 560 - 22	560	450	2097	9318	1640	24 x M30	900	213	264	632	568	27	660
		460	2201	9572									
		480	2420	10081									

*Locking bolts: standard DIN EN ISO 4014/4017 Grade 10.9, alternative DIN EN ISO 4762 Grade 10.9
M16 and upwards with washers: DIN EN ISO 7416

When ordering please state: (Type x Ød) e.g. HSD 280 - 22 x 280

Shrink Disc Type HSD – Series 22

Type	d mm	d _w mm	M _t kNm	P _{ax} kN	M _a Nm	B*	D mm	l mm	H ₁ mm	A mm	d ₁ mm	e mm	kg
HSD 590 - 22	590	470	2593	11032	1640	28 x M30	950	230	287	664	598	32	821
		480	2715	11314									
		500	2970	11881									
HSD 620 - 22	620	500	2904	11616	1640	28 x M30	960	254	310	706	630	30	872
		520	3169	12190									
		540	3447	12767									
HSD 660 - 22	660	530	3329	12562	2210	24 x M33	1020	260	320	748	670	34	1004
		550	3614	13140									
		570	3911	13722									
HSD 700 - 22	700	560	3804	13585	2210	28 x M33	1080	260	318	780	710	32	1141
		580	4109	14169									
		600	4427	14756									
HSD 750 - 22	750	600	4801	16004	2210	32 x M33	1150	278	344	846	760	38	1346
		620	5157	16636									
		650	5716	17589									
HSD 800 - 22	800	640	5620	17562	2210	30 x M33	1230	296	376	900	814	52	1646
		660	6012	18219									
		700	6839	19541									
HSD 850 - 22	850	650	5942	18282	2850	30 x M36	1300	315	386	950	860	43	1942
		700	6994	19983									
		730	7669	21011									
HSD 900 - 22	900	700	6967	19905	2850	32 x M36	1350	332	413	990	920	51	2142
		730	7640	20930									
		760	8345	21961									
HSD 950 - 22	950	750	8295	22121	2850	36 x M36	1400	360	438	1050	970	50	2425
		780	9041	23182									
		820	10088	24606									
HSD 1000 - 22	1000	800	9568	23920	2850	36 x M36	1460	380	461	1100	1020	53	2740
		830	10380	25013									
		860	11228	26111									
HSD 1050 - 22	1050	850	11241	26449	2850	36 x M36	1520	400	481	1150	1070	53	3078
		880	12135	27579									
		920	13383	29092									
HSD 1100 - 22	1100	900	13045	28990	2850	40 x M36	1570	430	511	1200	1120	53	3438
		930	14023	30156									
		960	15038	31328									
HSD 1200 - 22	1200	940	12902	27452	2850	40 x M36	1630	460	541	1300	1220	53	3566
		1000	14803	29606									
		1050	16493	31415									

Further sizes on request, subject to technical changes.

*Locking bolts: standard DIN EN ISO 4014/4017 Grade 10.9, alternative DIN EN ISO 4762 Grade 10.9
M16 and upwards with washers: DIN EN ISO 7416

When ordering please state: (Type x Ød) e.g. HSD 750 - 22 x 750

Shrink Disc Type HSD Series 23

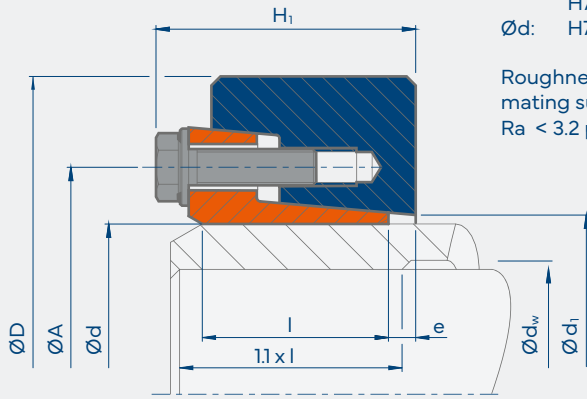

Information on fits:
 $\varnothing d_w$: H7/h6 ($\varnothing d_w < 160$)
 H7/g6 ($\varnothing d_w \geq 160$)
 $\varnothing d$: H7/f7

Roughness of all
 mating surfaces:
 $R_a < 3.2 \mu\text{m}$

Code

- M_t Maximum transmissible torque of a shrink disc for $P_{ax} = 0$
- P_{ax} Maximum transmissible axial load of a shrink disc for $M_t = 0$
- M_a Required tightening torque of the locking bolts (see also "Installation and Removal Instructions")

Dimensions H_1 and e apply to untightened units.

Type	d mm	d _w mm	M _t kNm	P _{ax} kN	M _a Nm	B*	D mm	l mm	H ₁ mm	A mm	d ₁ mm	e mm	kg
HSD 140 - 23	140	100	26	523	240	8 x M16	230	60	89	174	144	10	13.6
	135	105	30	562									
		115	37	641									
HSD 155 - 23	155	110	36	646	240	9 x M16	263	66	95	194	160	11	19.8
	150	115	40	687									
		125	48	772									
HSD 165 - 23	165	120	50	828	240	12 x M16	290	72	102	200	169	10	27.7
	160	125	55	877									
		135	66	977									
HSD 175 - 23	175	130	61	943	240	12 x M16	300	72	103	210	179	11	29
	170	135	67	993									
		145	79	1094									
HSD 185 - 23	185	140	89	1269	470	12 x M20	320	92	122	232	190	12	40.1
	180	145	96	1330									
		155	113	1455									
HSD 200 - 23	200	150	104	1391	470	12 x M20	340	92	125	246	204	15	44.5
	195	155	113	1453									
		165	130	1577									
HSD 220 - 23	220	160	127	1591	470	15 x M20	370	117	148	266	225	14	65.3
		165	137	1661									
		180	169	1876									
HSD 240 - 23	240	170	157	1847	470	16 x M20	405	122	154	286	245	15	81.6
		180	180	1996									
		200	230	2300									
HSD 260 - 23	260	190	230	2424	470	18 x M20	430	136	171	306	266	17	101
		200	260	2600									
		220	325	2957									
HSD 280 - 23	280	210	306	2918	820	16 x M24	460	148	185	334	286	16	126
		220	342	3105									
		240	418	3485									

*Locking bolts: standard DIN EN ISO 4014/4017 Grade 10.9, alternative DIN EN ISO 4762 Grade 10.9
 M16 and upwards with washers: DIN EN ISO 7416

When ordering please state: (Type x $\varnothing d$) e.g. HSD 240 - 23 x 240

Shrink Disc Type HSD – Series 23

Type	d mm	d _w mm	M _t kNm	P _{ax} kN	M _a Nm	B*	D mm	I mm	H ₁ mm	A mm	d ₁ mm	e mm	kg
HSD 300 - 21	300	250	191	1529	470	16 x M20	460	65	94	340	308	13	50.2
		260	209	1610									
		270	228	1691									
HSD 320 - 21	320	270	243	1804	470	20 x M20	485	77	106	364	327	13	64.5
		280	265	1894									
		290	288	1986									
HSD 340 - 21	340	280	274	1958	470	20 x M20	520	77	106	384	347	13	75
		290	297	2050									
		300	322	2143									
HSD 360 - 21	360	300	356	2373	470	20 x M20	570	89	122	410	368	13	113
		310	384	2476									
		330	443	2686									
HSD 390 - 21	390	330	438	2654	470	24 x M20	590	89	123	440	398	14	114
		340	469	2759									
		350	501	2865									
HSD 420 - 21	420	350	624	3564	820	18 x M24	630	120	160	470	427	21	166
		360	665	3697									
		370	709	3831									
HSD 440 - 21	440	370	778	4203	820	20 x M24	660	132	174	494	448	21	203
		380	826	4350									
		390	877	4497									
HSD 460 - 21	460	390	852	4370	820	20 x M24	690	132	174	516	468	21	222
		400	903	4514									
		410	955	4658									
HSD 480 - 21	480	410	1086	5298	820	24 x M24	720	152	194	540	487	23	274
		420	1147	5461									
		430	1210	5626									
HSD 500 - 21	500	420	1137	5415	820	24 x M24	745	152	197	560	508	24	293
		430	1200	5581									
		450	1331	5914									
HSD 530 - 21	530	450	1376	6114	1210	24 x M27	790	166	209	594	540	20	359
		460	1446	6287									
		480	1592	6635									
HSD 560 - 21	560	480	1578	6576	1210	28 x M27	830	166	211	626	570	22	393
		490	1653	6748									
		510	1809	7093									
HSD 590 - 21	590	510	1873	7344	1210	24 x M27	880	172	219	658	599	26	452
		520	1957	7526									
		540	2131	7891									
HSD 620 - 21	620	540	2097	7768	1210	24 x M27	930	172	222	690	629	28	516
		550	2186	7948									
		570	2368	8309									
HSD 660 - 21	660	570	2426	8511	1640	24 x M30	990	182	235	734	670	29	619
		580	2522	8696									
		610	2823	9255									
HSD 700 - 21	700	610	2772	9088	1640	24 x M30	1040	182	234	774	710	28	694
		620	2874	9271									
		640	3084	9638									
HSD 750 - 21	750	640	3104	9700	1640	28 x M30	1100	192	246	826	760	30	777
		650	3214	9888									
		680	3555	10456									
HSD 800 - 21	800	680	3443	10128	1640	28 x M30	1150	192	248	876	809	32	819
		700	3673	10495									
		730	4033	11049									

Further sizes on request, subject to technical changes.

*Locking bolts: standard DIN EN ISO 4014/4017 Grade 10.9, alternative DIN EN ISO 4762 Grade 10.9
M16 and upwards with washers: DIN EN ISO 7416

When ordering please state: (Type x Ød) e.g. HSD 660 - 21 x 660

Shrink Disc Type HSD Series 81

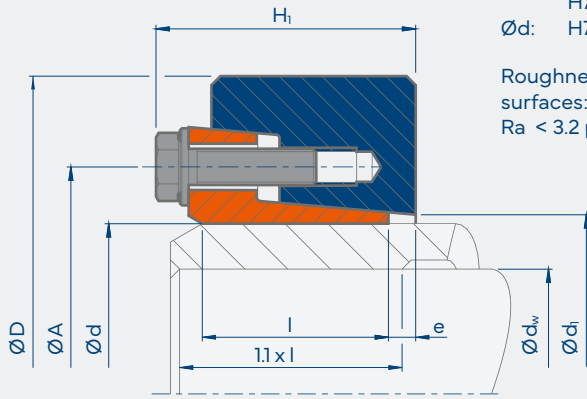

Information on fits:
 $\varnothing d_w$: H7/h6 ($\varnothing d_w < 160$)
 H7/g6 ($\varnothing d_w \geq 160$)
 $\varnothing d$: H7/f7
 Roughness of all mating surfaces:
 $R_a < 3.2 \mu\text{m}$

Code

- M_t Maximum transmissible torque of a shrink disc for $P_{ax} = 0$
- P_{ax} Maximum transmissible axial load of a shrink disc for $M_t = 0$
- M_a Required tightening torque of the locking bolts (see also "Installation and Removal Instructions")

Dimensions H_1 and e apply to untightened units.

Type	d mm	d _w mm	M _t kNm	P _{ax} kN	M _a Nm	B*	D mm	l mm	H ₁ mm	A mm	d ₁ mm	e mm	kg
HSD 50 - 81	50	38	1.5	79	35	8 x M8	90	22	34	68	53	4.4	0.9
		40	1.7	87									
		42	2.0	94									
HSD 55 - 81	55	42	1.6	78	35	8 x M8	100	23	36	72	58	4.4	1.2
		45	2.0	88									
		48	2.4	99									
HSD 62 - 81	62	48	2.2	92	35	9 x M8	110	23	36	80	66	4.4	1.4
		60	2.5	98									
		52	2.7	105									
HSD 68 - 81	68	50	2.4	94	35	9 x M8	115	23	36	86	72	4.4	1.4
		55	3.0	111									
		60	3.8	128									
HSD 75 - 81	75	55	3.7	135	70	10 x M10	138	25	40	100	79	4.6	2.5
		60	4.7	156									
		65	5.8	177									
HSD 80 - 81	80	60	4.2	141	70	10 x M10	141	25	41	104	84	5.6	2.5
		65	5.2	160									
		70	6.3	180									
HSD 90 - 81	90	65	5.9	182	70	10 x M10	155	30	47	114	94	6.1	3.5
		85	7.2	204									
		75	8.5	227									
HSD 100 - 81	100	70	7.4	213	70	12 x M10	170	34	51	124	104	5.1	4.7
		95	8.9	236									
		80	10.4	260									
HSD 110 - 81	110	80	12.6	314	120	12 x M12	185	39	60	137	114	6.5	6.3
		105	14.6	345									
		90	16.9	376									
HSD 120 - 81	120	85	13.6	320	120	12 x M12	197	42	63	147	124	6.5	7.8
		115	15.7	349									
		95	18.0	379									

*Locking bolts: standard DIN EN ISO 4014/4017 Grade 12.9, alternative DIN EN ISO 4762 Grade 12.9
 M16 and upwards with washers: DIN EN ISO 7416

When ordering please state: (Type x $\varnothing d$) e.g. HSD 62 - 81 x 60

Shrink Disc Type HSD – Series 81

Type	d mm	d _w mm	M _t kNm	P _{ax} kN	M _a Nm	B*	D mm	l mm	H ₁ mm	A mm	d ₁ mm	e mm	kg
HSD 125 - 81	125	90	16.4	365	120	12 x M12	215	42	63	152	129	6.5	9.3
		95	18.8	395									
		100	21.3	425									
HSD 135 - 81	135	95	20.3	428	193	10 x M14	230	46	69	165	139	7.2	11.5
		130	23.0	461									
		110	29.0	527									
HSD 140 - 81	140	100	23.0	460	193	12 x M14	230	46	70	172	146	8.2	11.5
		105	25.9	493									
		115	32.2	561									
HSD 155 - 81	155	110	31.1	566	193	12 x M14	263	50	74	186	159	8.7	16
		150	34.6	602									
		125	42.1	673									
HSD 165 - 81	165	120	44.0	734	295	12 x M16	290	56	85	198	169	9	22.5
		160	48.5	776									
		135	58.1	860									
HSD 175 - 81	175	130	54	831	295	12 x M16	300	56	86	208	179	10	23.5
		170	59	874									
		145	70	960									
HSD 185 - 81	185	140	81	1153	295	16 x M16	320	71	103	222	191	11	33.5
		180	88	1207									
		155	102	1315									
HSD 200 - 81	200	150	96	1280	295	16 x M16	340	71	103	238	206	11	37
		195	103	1335									
		190	119	1446									
HSD 220 - 81	220	160	129	1614	570	15 x M20	370	93	122	270	230	13	52
		170	149	1751									
		180	170	1888									
HSD 240 - 81	240	170	151	1778	570	16 x M20	405	95	125	288	248	13	64
		180	172	1916									
		200	220	2195									
HSD 260 - 81	260	190	212	2234	570	15 x M20	430	105	137	306	268	15	78
		200	239	2391									
		220	298	2707									
HSD 280 - 81	280	210	279	2657	570	16 x M20	460	114	149	328	288	19	95
		220	311	2823									
		240	379	3158									
HSD 300 - 81	300	220	332	3016	900	16 x M24	485	123	158	354	308	16	113
		230	367	3194									
		250	444	3554									
HSD 320 - 81	320	240	404	3371	900	18 x M24	520	125	160	380	328	15	133
		250	444	3554									
		270	530	3924									
HSD 340 - 81	340	250	489	3909	900	18 x M24	570	134	171	402	349	17	178
		260	534	4109									
		280	632	4511									
HSD 360 - 81	360	270	625	4626	900	20 x M24	590	140	179	416	369	19	195
		280	678	4841									
		300	791	5275									
HSD 390 - 81	390	290	780	5377	1310	18 x M27	650	146	190	454	398	21	249
		300	841	5608									
		320	972	6074									
HSD 420 - 81	420	320	969	6055	1310	18 x M27	680	167	211	490	428	22	300
		330	1038	6292									
		350	1185	6769									

*Locking bolts: standard DIN EN ISO 4014/4017 Grade 12.9, alternative DIN EN ISO 4762 Grade 12.9

M16 and upwards with washers: DIN EN ISO 7416

When ordering please state: (Type x Ød) e.g. HSD 360 - 81 x 360

Shrink Disc Type HSD – Series 81

Type	d mm	d _w mm	M _t kNm	P _{ex} kN	M _a Nm	B*	D mm	I mm	H ₁ mm	A mm	d ₁ mm	e mm	kg
HSD 440 - 81	440	340	1212	7129	1310	21 x M27	725	174	222	506	448	25	363
		350	1293	7386									
		370	1462	7904									
HSD 460 - 81	460	360	1397	7759	1310	21 x M27	745	174	225	534	470	28	376
		370	1484	8020									
		390	1666	8545									
HSD 480 - 81	480	380	1658	8729	1800	20 x M30	790	192	243	552	488	26	476
		390	1756	9006									
		410	1961	9564									
HSD 500 - 81	500	400	1888	9441	1800	21 x M30	835	192	244	572	508	27	540
		410	1994	9727									
		430	2215	10304									
HSD 530 - 81	530	430	2397	11148	1800	24 x M30	890	213	270	606	541	33	680
		440	2521	11461									
		460	2781	12090									
HSD 560 - 81	560	450	2546	11314	1800	24 x M30	920	213	268	632	568	31	710
		460	2672	11617									
		480	2934	12225									
HSD 590 - 81	590	470	2969	12634	1800	28 x M30	960	230	288	664	598	33	830
		480	3109	12955									
		500	3400	13600									
HSD 620 - 81	620	500	3404	13617	1800	28 x M30	970	254	314	706	630	34	900
		520	3713	14281									
		540	4036	14949									
HSD 660 - 81	660	530	4034	15222	2400	24 x M33	1060	260	326	748	670	38	1120
		550	4373	15902									
		570	4726	16584									
HSD 700 - 81	700	560	4605	16447	2400	28 x M33	1140	260	321	780	710	35	1320
		580	4969	17134									
		600	5347	17823									
HSD 750 - 81	750	600	5806	19354	2400	32 x M33	1200	278	345	846	760	42	1540
		620	6231	20099									
		650	6896	21219									
HSD 800 - 81	800	640	6798	21244	2400	32 x M33	1270	296	376	900	810	54	1835
		660	7265	22016									
		700	8249	23569									
HSD 850 - 81	850	650	7214	22197	3100	30 x M36	1340	315	392	950	860	49	2154
		700	8470	24199									
		730	9274	25408									
HSD 900 - 81	900	700	8453	24152	3100	32 x M36	1400	332	419	990	915	56	2433
		730	9256	25360									
		760	10098	26573									
HSD 950 - 81	950	750	10060	26826	3100	36 x M36	1450	360	444	1050	965	56	2752
		780	10949	28076									
		820	12197	29750									

Further sizes on request, subject to technical changes.

*Locking bolts: standard DIN EN ISO 4014/4017 Grade 12.9, alternative DIN EN ISO 4762 Grade 12.9

M16 and upwards with washers: DIN EN ISO 7416

When ordering please state: (Type x Ød) e.g. HSD 950 - 81 x 950

Shrink Disc Type HSD Series 83

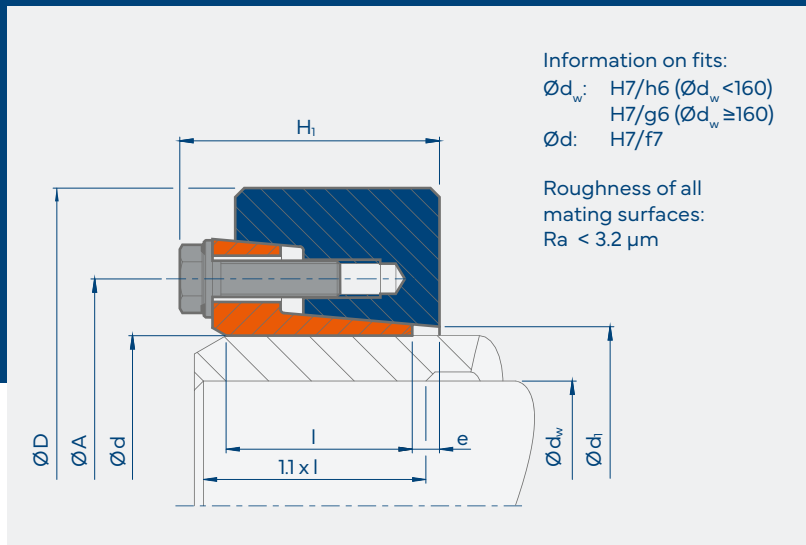

Code

- M_t Maximum transmissible torque of a shrink disc for $P_{ax} = 0$
- P_{ax} Maximum transmissible axial load of a shrink disc for $M_t = 0$
- M_a Required tightening torque of the locking bolts (see also "Installation and Removal Instructions")

Dimensions H_1 and e apply to untightened units.

Shrink Disc Type HSD – Series 83

Type	d mm	d_w mm	M_t kNm	P_{ax} kN	M_a Nm	B*	D mm	l mm	H_1 mm	A mm	d_1 mm	e mm	kg
HSD 140 - 83	140	100	30	608	295	8 x M16	240	60	89	174	144	10	15.5
	135	105	34	652									
		115	43	742									
HSD 155 - 83	155	110	45	816	295	9 x M16	263	66	95	194	160	11	20
	150	115	50	867									
		125	61	970									
HSD 165 - 83	165	120	64	1062	295	12 x M16	290	72	103	200	169	11	28
	160	125	70	1122									
		135	84	1244									
HSD 175 - 83	175	130	74	1132	295	12 x M16	300	72	104	210	179	12	29
	170	135	80	1191									
		145	95	1309									
HSD 185 - 83	185	140	106	1519	570	12 x M20	320	92	124	232	189	14	40.5
	180	145	115	1592									
		155	135	1737									
HSD 200 - 83	200	150	127	1696	570	12 x M20	340	92	124	246	204	14	44.5
	195	155	137	1769									
		165	158	1917									
HSD 220 - 83	220	160	163	2042	570	15 x M20	370	117	149	266	224	15	65.5
		165	176	2128									
		180	215	2391									
HSD 240 - 83	240	170	209	2459	570	16 x M20	405	122	154	286	244	15	82
		180	238	2647									
		200	303	3029									
HSD 260 - 83	260	190	288	3036	570	18 x M20	430	136	173	306	265	19	100
		200	325	3247									
		220	404	3675									
HSD 280 - 83	280	210	361	3437	900	18 x M24	460	148	186	334	285	17	126
		220	402	3654									
		240	491	4092									

*Locking bolts: standard DIN EN ISO 4014/4017 Grade 12.9, alternative DIN EN ISO 4762 Grade 12.9
 M16 and upwards with washers: DIN EN ISO 7416

When ordering please state: (Type x $\varnothing d$) e.g. HSD 200 - 83 x 195

Shrink Disc Type HSD – Series 83

Type	d mm	d _w mm	M _t kNm	P _{ax} kN	M _a Nm	B*	D mm	l mm	H ₁ mm	A mm	d ₁ mm	e mm	kg
HSD 300 - 83	300	230	465	4047	900	16 x M24	485	152	190	354	305	18	141
		240	513	4273									
		250	563	4501									
HSD 320 - 83	320	240	510	4250	900	18 x M24	520	160	200	374	325	19	171
		250	560	4484									
		270	669	4955									
HSD 340 - 83	340	250	664	5316	1310	18 x M27	570	176	221	404	345	21	234
		260	726	5587									
		280	859	6135									
HSD 360 - 83	360	270	763	5655	1310	18 x M27	590	180	226	424	365	22	249
		280	829	5921									
		300	969	6457									
HSD 390 - 83	390	290	972	6703	1310	20 x M27	650	190	240	456	398	26	325
		300	1049	6994									
		320	1213	7580									
HSD 420 - 83	420	320	1297	8105	1310	21 x M27	690	214	268	486	428	30	404
		330	1389	8421									
		350	1585	9057									
HSD 440 - 83	440	340	1585	9323	1800	21 x M30	750	225	284	514	448	31	530
		350	1690	9659									
		370	1912	10336									
HSD 460 - 83	460	360	1747	9706	1800	21 x M30	760	226	280	534	468	30	520
		370	1856	10035									
		390	2086	10697									
HSD 480 - 83	480	380	2105	11076	1800	21 x M30	800	246	309	552	488	37	640
		390	2229	11430									
		410	2489	12142									
HSD 500 - 83	500	400	2552	12762	1800	24 x M30	850	246	306	572	508	34	740
		410	2695	13147									
		430	2993	13922									
HSD 530 - 83	530	430	3108	14455	2400	21 x M33	890	280	346	616	538	40	900
		440	3270	14861									
		460	3606	15678									
HSD 560 - 83	560	450	3452	15341	2400	24 x M33	940	280	344	646	568	36	1000
		460	3622	15749									
		480	3976	16567									
HSD 590 - 83	590	470	4027	17138	2400	24 x M33	980	296	369	666	600	41	1150
		480	4217	17571									
		500	4610	18439									
HSD 620 - 83	620	500	5040	20160	2400	27 x M33	1020	330	406	706	630	46	1370
		510	5263	20641									
		540	5964	22089									
HSD 660 - 83	660	530	5833	22013	3100	28 x M36	1090	334	405	750	670	43	1570
		540	6075	22501									
		570	6832	23972									
HSD 700 - 83	700	560	6485	23160	3100	27 x M36	1160	334	416	800	710	48	1810
		570	6738	23642									
		600	7528	25095									
HSD 750 - 83	750	600	7671	25569	3100	30 x M36	1220	370	446	850	760	48	2140
		620	8234	26562									
		650	9119	28059									
HSD 800 - 83	800	640	9085	28390	3100	36 x M36	1340	360	460	900	810	60	2651
		660	9709	29422									
		700	11024	31497									
HSD 850 - 83	850	650	8924	27459	3100	36 x M36	1440	380	469	950	860	60.5	3271
		700	10474	29927									
		730	11467	31416									
HSD 900 - 83	900	700	10259	29310	3100	38 x M36	1470	400	493	1010	912	64	3370
		730	11233	30774									
		760	12253	32245									
HSD 950 - 83	950	750	12147	32392	3100	40 x M36	1520	430	525	1050	970	66.5	3805
		780	13220	33898									
		820	14726	35917									

Further sizes on request, subject to technical changes.

*Locking bolts: standard DIN EN ISO 4014/4017 Grade 12.9, alternative DIN EN ISO 4762 Grade 12.9

M16 and upwards with washers: DIN EN ISO 7416

When ordering please state: (Type x Ød) e.g. HSD 950 - 83 x 950

Shrink disc Type HSD Rust-free Series 20 - 1.4122

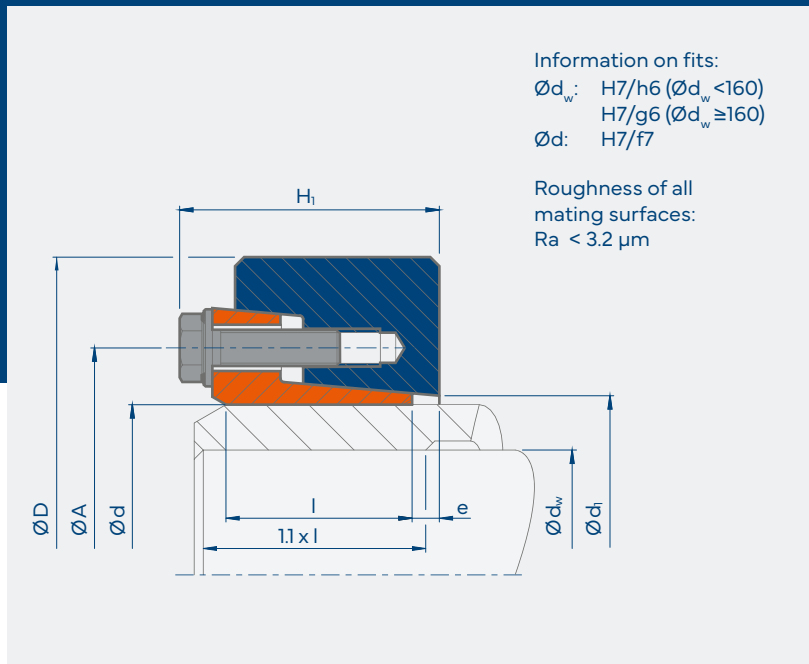

Information on fits:
 $\varnothing d_w$: H7/h6 ($\varnothing d_w < 160$)
 H7/g6 ($\varnothing d_w \geq 160$)
 $\varnothing d$: H7/f7

Roughness of all mating surfaces:
 $R_a < 3.2 \mu\text{m}$

Code

M_t Maximum transmissible torque of a shrink disc for $P_{ax} = 0$

P_{ax} Maximum transmissible axial load of a shrink disc for $M_t = 0$

M_a Required tightening torque of the locking bolts (see also "Installation and Removal Instructions")

μ_w The transmissible loads on rust-free materials are calculated using the coefficient of friction $\mu_w = 0.1$

Dimensions H_1 and e apply to untightened units.

Shrink Disc Type HSD Rust-free – Series 20 - 1.4122

Type	d mm	d _w mm	M _t kNm	P _{ax} kN	M _a Nm	B*	D mm	l mm	H ₁ mm	A mm	d _i mm	e mm	kg
HSD 24 - 20	24	20	0.08	8	10	6 x M6	50	11.5	18	38	25	1.8	0.2
		21	0.10	10									
		22	0.12	11									
HSD 29 - 20	29	25	0.13	10	10	6 x M6	58	12.5	18	44	31	1.8	0.2
		26	0.15	11									
		27	0.17	13									
HSD 35 - 20	34	29	0.15	10	10	5 x M6	64	12.5	18	52	38	1.8	0.25
		35	0.17	11									
		32	0.21	13									
HSD 40 - 20	38	34	0.19	11	10	6 x M6	69	12.2	18	55	43	2.5	0.3
		40	0.21	12									
		36	0.23	13									
HSD 46 - 20	46	38	0.24	13	10	6 x M6	80	13	23	62	50	2.5	0.5
		47	0.30	15									
		42	0.36	17									
HSD 51 - 20	51	44	0.35	16	10	8 x M6	86	13	23	67	54	2.5	0.5
		45	0.38	17									
		47	0.45	19									
HSD 56 - 20	55	48	0.37	15	10	8 x M6	90	13	23	72	59	2.9	0.6
		56	0.43	17									
		57	0.49	19									
HSD 61 - 20	61	53	0.47	18	10	8 x M6	96	13	24	76	63	2.9	0.7
		55	0.55	20									
		57	0.63	22									
HSD 66 - 20	65	58	0.51	18	10	8 x M6	100	13	24	82	68	2.9	0.7
		66	0.58	19									
		62	0.66	21									

*Locking bolts: standard DIN EN ISO 4014/4017 Grade A4-80 M16 and upwards with washers: DIN EN ISO 7416, **When ordering please state:** (Type x \varnothing) e.g. HSD 61 - 20 x 61 - 61 - 1.4122

Shrink Disc Type HSD Rust-free – Series 20 - 1.4122

Type	d mm	d _w mm	M _t kNm	P _{ax} kN	M _a Nm	B*	D mm	l mm	H ₁ mm	A mm	d ₁ mm	e mm	kg
HSD 73 - 20	70	63	0.63	20	24	9 x M8	115	18	30	94	77	3.2	1.2
	72	65	0.72	22									
	73	68	0.87	26									
HSD 78 - 20	76	68	0.78	23	24	9 x M8	120	18	30	100	82	3.2	1.3
	78	70	0.87	25									
	72		0.98	27									
HSD 83 - 20	81	73	0.87	24	24	9 x M8	125	18	30	104	87	3.2	1.3
	83	75	0.96	26									
	77		1.07	28									
HSD 88 - 20	86	78	0.98	25	24	9 x M8	130	18	30	110	92	3.5	1.4
	88	80	1.08	27									
	82		1.19	29									
HSD 93 - 20	93	83	1.16	28	24	9 x M8	135	18	31	114	97	3.5	1.4
	94	85	1.28	30									
	87		1.40	32									
HSD 98 - 20	96	88	1.18	27	24	9 x M8	140	18	31	120	102	3.5	1.5
	98	90	1.30	29									
	92		1.42	31									
HSD 103 - 20	103	93	1.44	31	24	10 x M8	145	18	31	124	107	3.5	1.5
		95	1.56	33									
		97	1.69	35									
HSD 108 - 20	106	98	1.46	30	24	10 x M8	150	18	31	128	112	3.5	1.6
	108	100	1.58	32									
		102	1.71	34									
HSD 115 - 20	112	103	1.99	39	24	10 x M8	160	22	35	134	118	3.9	2.2
	115	105	2.14	41									
		108	2.38	44									
HSD 120 - 20	120	108	2.24	42	24	10 x M8	164	22	35	140	124	3.9	2.2
		110	2.40	44									
		113	2.65	47									
HSD 125 - 20	125	113	2.35	42	24	12 x M8	169	22	35	144	129	3.9	2.3
		115	2.50	44									
		118	2.75	47									
HSD 130 - 20	130	118	2.56	43	24	12 x M8	174	22	35	150	134	3.9	2.3
		120	2.72	45									
		123	2.97	48									
HSD 135 - 20	135	123	2.69	44	24	12 x M8	179	22	35	154	139	3.9	2.3
		125	2.86	46									
		128	3.13	49									
HSD 140 - 20	138	128	2.71	42	24	12 x M8	184	22	36	160	144	4.5	2.5
	140	130	2.88	44									
		132	3.05	46									
HSD 145 - 20	145	133	3.02	45	24	12 x M8	189	22	36	164	149	4.5	2.6
		135	3.20	47									
		137	3.38	49									
HSD 150 - 20	150	138	3.25	47	24	12 x M8	194	22	36	170	154	4.5	2.6
		140	3.43	49									
		142	3.61	51									
HSD 160 - 20	160	146	3.41	47	24	12 x M8	204	22	36	180	164	4.5	2.7
		150	3.77	50									
		152	3.96	52									

*Locking bolts: standard DIN EN ISO 4014/4017 Grade A4-80 M16 and upwards with washers:
DIN EN ISO 7416, **When ordering please state:** (Type x Ød) e.g. HSD 140 - 20 x 138 - 1.4122

Shrink Disc Type HSD Rust-free – Series 20 - 1.4122

Type	d mm	d _w mm	M _t kNm	P _{ax} kN	M _a Nm	B*	D mm	l mm	H ₁ mm	A mm	d ₁ mm	e mm	kg
HSD 170 - 20	166	156	3.45	44	24	12 x M8	214	22	36	190	174	4.5	3
	170	160	3.81	48									
		162	3.99	49									
HSD 182 - 20	182	166	4.88	59	24	14 x M8	230	25	41	206	188	5.6	3.9
		170	5.36	63									
		172	5.61	65									
HSD 192 - 20	189	176	5.03	57	24	14 x M8	240	25	41	216	198	5.6	4
		180	5.50	61									
		182	5.74	63									
HSD 202 - 20	202	186	5.66	61	24	15 x M8	250	25	41	224	208	5.6	4.7
		190	6.18	65									
		192	6.45	67									
HSD 212 - 20	212	196	6.27	64	24	15 x M8	260	25	41	234	218	5.6	4.7
		200	6.81	68									
		202	7.08	70									
HSD 222 - 20	222	206	6.73	65	24	16 x M8	270	25	42	244	228	6.5	5
		210	7.27	69									
		212	7.54	71									
HSD 232 - 20	232	216	7.18	66	24	16 x M8	280	25	42	254	238	6.5	5
		220	7.73	70									
		222	8.01	72									
HSD 242 - 20	242	226	7.63	68	24	16 x M8	290	25	42	264	248	6.5	5
		230	8.19	71									
		232	8.47	73									
HSD 252 - 20	252	234	7.84	67	24	16 x M8	300	25	42	274	258	6.5	5.2
		238	8.39	71									
		240	8.67	72									
HSD 262 - 20	262	244	8.30	68	24	18 x M8	310	25	42	286	268	6.5	5.4
		248	8.86	71									
		250	9.14	73									

Further sizes on request, subject to technical changes.

*Locking bolts: standard DIN EN ISO 4014/4017 Grade A4-80

M16 and upwards with washers: DIN EN ISO 7416

When ordering please state: (Type x Ød) e.g. HSD 202 - 20 x 202 - 61 - 1.4122

Shrink Disc Type HSD Rust-free Series 20 - 1.4462

Information on fits:
 $\varnothing d_w$: H7/h6 ($\varnothing d_w < 160$)
 H7/g6 ($\varnothing d_w \geq 160$)
 $\varnothing d$: H7/f7

Roughness of all
 mating surfaces:
 $R_a < 3.2 \mu\text{m}$

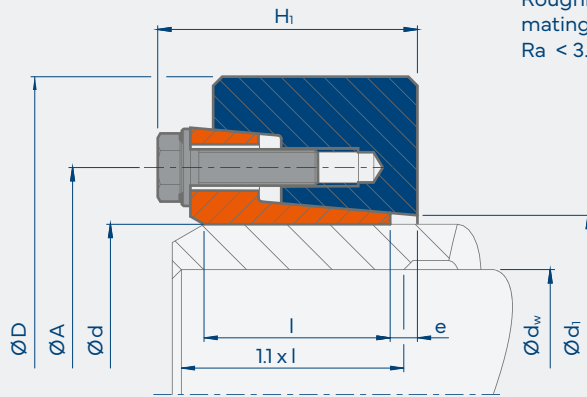

Code

M_t Maximum transmissible torque of a shrink disc for $P_{ax} = 0$

P_{ax} Maximum transmissible axial load of a shrink disc for $M_t = 0$

M_a Required tightening torque of the locking bolts (see also "Installation and Removal Instructions")

μ_w The transmissible loads on rust-free materials are calculated based upon the coefficient of friction $\mu_w = 0.1$

Dimensions H_1 and e apply to untightened units.

Type	d mm	d _w mm	M _t kNm	P _{ax} kN	M _a Nm	B*	D mm	l mm	H ₁ mm	A mm	d _i mm	e mm	kg
HSD 24 - 20	24	20	0.06	6	10	6 x M6	50	11.5	18	38	25	1.8	0.2
		21	0.07	7									
		22	0.09	8									
HSD 29 - 20	29	25	0.09	8	10	6 x M6	58	12.5	18	44	31	1.8	0.2
		26	0.11	9									
		27	0.13	10									
HSD 35 - 20	34	29	0.11	8	10	6 x M6	64	12.5	18	52	38	1.8	0.25
		35	0.13	8									
		32	0.16	10									
HSD 40 - 20	38	34	0.14	8	10	6 x M6	69	12.2	18	55	43	2.5	0.3
		40	0.16	9									
		36	0.18	10									
HSD 46 - 20	46	38	0.16	8	10	6 x M6	80	13	23	62	50	2.5	0.5
		47	0.20	10									
		42	0.25	12									
HSD 51 - 20	51	44	0.24	11	10	8 x M6	86	13	23	67	54	2.5	0.5
		45	0.26	12									
		47	0.32	14									
HSD 56 - 20	55	48	0.24	10	10	8 x M6	90	13	23	72	59	2.9	0.6
		56	0.29	12									
		57	0.35	13									
HSD 61 - 20	61	53	0.32	12	10	8 x M6	96	13	24	76	63	2.9	0.7
		55	0.38	14									
		57	0.45	16									
HSD 66 - 20	65	58	0.34	12	10	8 x M6	100	13	24	82	68	2.9	0.7
		66	0.40	13									
		62	0.46	15									

*Locking bolts: standard DIN EN ISO 4014/4017 Grade A4-80
 M16 and upwards with washers: DIN EN ISO 7416

When ordering please state: (Type x $\varnothing d$) e.g. HSD 61 - 20 x 61 - 61 - 1.4462

Shrink Disc Type HSD Rust-free – Series 20 - 1.4462

Type	d mm	d _w mm	M _t kNm	P _{ax} kN	M _a Nm	B*	D mm	l mm	H ₁ mm	A mm	d ₁ mm	e mm	kg
HSD 73 - 20	70	63	0.38	12	24	9 x M8	115	18	30	94	77	3.2	1.2
	72	65	0.46	14									
	73	68	0.58	17									
HSD 78 - 20	76	68	0.51	15	24	9 x M8	120	18	30	100	82	3.2	1.3
	78	70	0.59	17									
	72	72	0.67	19									
HSD 83 - 20	81	73	0.57	16	24	9 x M8	125	18	30	104	87	3.2	1.3
	83	75	0.65	17									
	77	77	0.74	19									
HSD 88 - 20	86	78	0.66	17	24	9 x M8	130	18	30	110	92	3.5	1.4
	88	80	0.74	19									
	82	82	0.83	20									
HSD 93 - 20	93	83	0.82	20	24	9 x M8	135	18	31	114	97	3.5	1.4
	94	85	0.92	22									
	87	87	1.02	24									
HSD 98 - 20	96	88	0.82	19	24	9 x M8	140	18	31	120	102	3.5	1.5
	98	90	0.91	20									
	92	92	1.02	22									
HSD 103 - 20	103	93	1.01	22	24	10 x M8	145	18	31	124	107	3.5	1.5
	95	95	1.11	23									
	97	97	1.22	25									
HSD 108 - 20	106	98	1.03	21	24	10 x M8	150	18	31	128	112	3.5	1.6
	108	100	1.13	23									
	102	102	1.24	24									
HSD 115 - 20	112	103	1.39	27	24	10 x M8	160	22	35	134	118	3.9	2.2
	115	105	1.52	29									
	108	108	1.72	32									
HSD 120 - 20	120	108	1.65	31	24	10 x M8	164	22	35	140	124	3.9	2.2
	110	110	1.79	32									
	113	113	2.00	35									
HSD 125 - 20	125	113	1.72	30	24	12 x M8	169	22	35	144	129	3.9	2.3
	115	115	1.86	32									
	118	118	2.07	35									
HSD 130 - 20	130	118	1.85	31	24	12 x M8	174	22	35	150	134	3.9	2.3
	120	120	1.99	33									
	123	123	2.20	36									
HSD 135 - 20	135	123	1.89	31	24	12 x M8	179	22	35	154	139	3.9	2.3
	125	125	2.04	33									
	128	128	2.27	35									
HSD 140 - 20	138	128	1.93	30	24	12 x M8	184	22	36	160	144	4.5	2.5
	140	130	2.08	32									
	132	132	2.23	34									
HSD 145 - 20	145	133	2.21	33	24	12 x M8	189	22	36	164	149	4.5	2.6
	135	135	2.36	35									
	137	137	2.52	37									
HSD 150 - 20	150	138	2.34	34	24	12 x M8	194	22	36	170	154	4.5	2.6
	140	140	2.50	36									
	142	142	2.66	37									
HSD 160 - 20	160	146	2.46	34	24	12 x M8	204	22	36	180	164	4.5	2.7
	150	150	2.77	37									
	152	152	2.93	39									

*Locking bolts: DIN EN ISO 4014/4017 grade A4-80 as standard,
M16 and upwards with washers: DIN EN ISO 7416,

When ordering please state: (Type x Ød) e.g. HSD 140 - 20 x 138 - 1.4462

Shrink Disc Type HSD Rust-free – Series 20 - 1.4462

Type	d mm	d _w mm	M _t kNm	P _{ax} kN	M _a Nm	B*	D mm	l mm	H ₁ mm	A mm	d ₁ mm	e mm	kg
HSD 170 - 20	166	156	2.43	31	24	12 x M8	214	22	36	190	174	4.5	3
	170	160	2.73	34									
		162	2.89	36									
HSD 182 - 20	182	166	3.59	43	24	14 x M8	230	25	41	206	188	5.6	3.9
		170	4.00	47									
		172	4.22	49									
HSD 192 - 20	189	176	3.64	41	24	14 x M8	240	25	41	216	198	5.6	4
		192	4.05	45									
		182	4.26	47									
HSD 202 - 20	202	186	4.11	44	24	15 x M8	250	25	41	224	208	5.6	4.7
		190	4.56	48									
		192	4.79	50									
HSD 212 - 20	212	196	4.54	46	24	15 x M8	260	25	41	234	218	5.6	4.7
		200	5.00	50									
		202	5.24	52									
HSD 222 - 20	222	206	4.90	48	24	16 x M8	270	25	42	244	228	6.5	5
		210	5.36	51									
		212	5.61	53									
HSD 232 - 20	232	216	5.35	50	24	16 x M8	280	25	42	254	238	6.5	5
		220	5.83	53									
		222	6.07	55									
HSD 242 - 20	242	226	5.71	51	24	16 x M8	290	25	42	264	248	6.5	5
		230	6.19	54									
		232	6.44	56									
HSD 252 - 20	252	234	5.76	49	24	16 x M8	300	25	42	274	258	6.5	5.2
		238	6.23	52									
		240	6.48	54									
HSD 262 - 20	262	244	6.12	50	24	18 x M8	310	25	42	286	268	6.5	5.4
		248	6.60	53									
		250	6.84	55									

Further sizes on request, subject to technical changes.

*Locking bolts: standard DIN EN ISO 4014/4017 Grade A4-80

M16 and upwards with washers: DIN EN ISO 7416

When ordering please state: (Type x Ød) e.g. HSD 202 - 20 x 202 - 61 - 1.4462

You have not found what you are looking for in our comprehensive range of standard-products?
We will be happy to promptly prepare any form of custom-made product and development innovation
even using special materials such as 1.3974. Please feel free to contact us.

Shrink Disc

Type HSD – Special Solutions

Individual solution UHSD

Example: Internal locking frictional connection

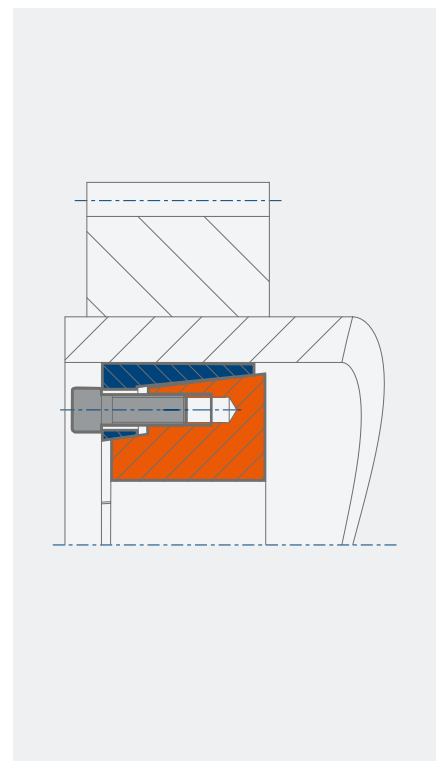
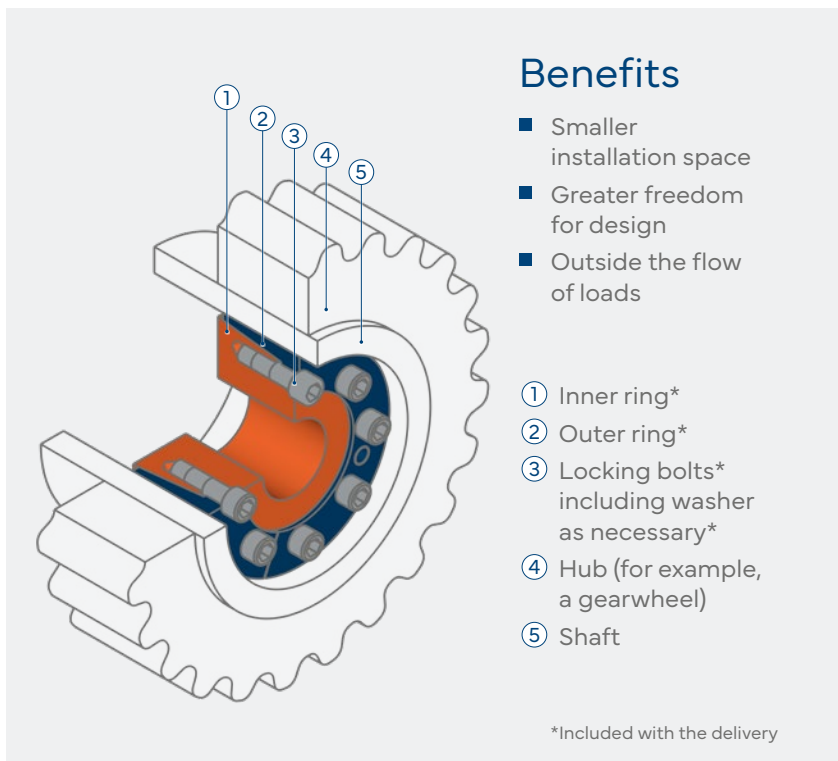

HSD with integrated spacer

Integration of partial solutions into the connection element

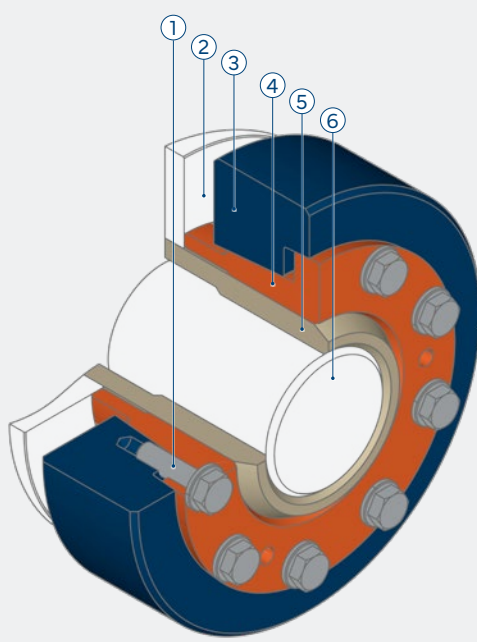

Benefits

- Less components
- Easier and safer installation

- ① Locking bolts* including washer as necessary*
- ② Component to be positioned (e.g. a bearing)
- ③ Outer ring*
- ④ Inner ring with integrated spacer sleeve*
- ⑤ Hub
- ⑥ Shaft

*Included with the delivery



Double-function HSD with Grooves

Connection element and seal

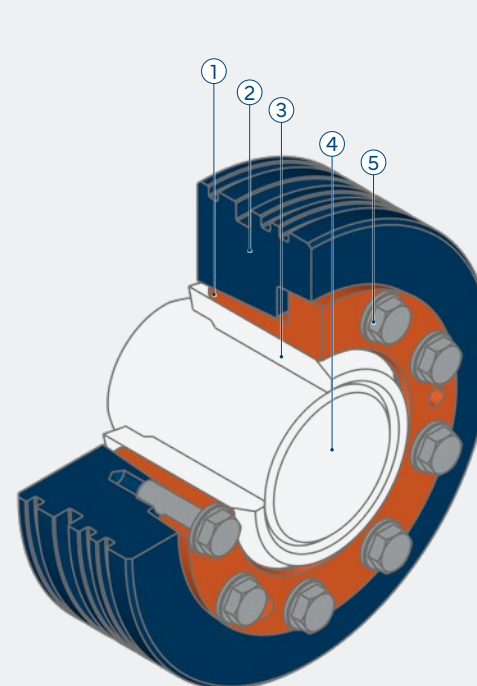

Benefits

- Less components
- Easier handling

- ① Inner ring*
- ② Outer ring*
- ③ Hollow shaft
- ④ Shaft
- ⑤ Locking bolts* including washer as necessary*

*Included with the delivery

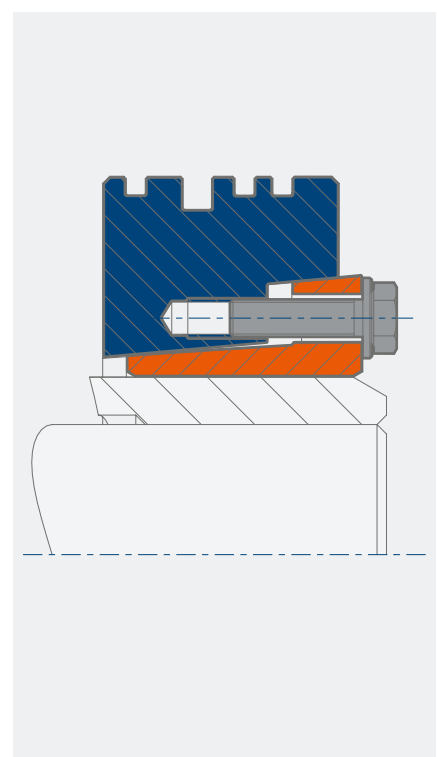

HSD with External Teeth

Connection element with mating external contour

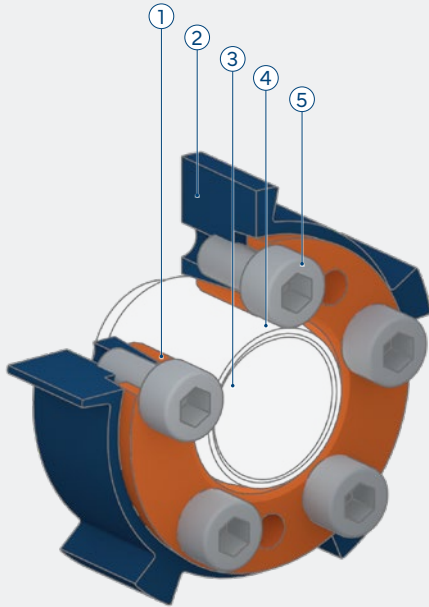

Benefits

- Less components
- Teeth integrated in the component
- Design of the external contour can be varied

- ① Inner ring*
- ② Outer ring*
- ③ Shaft
- ④ Hub
- ⑤ Locking bolts* including washer as necessary*

*Included with the delivery

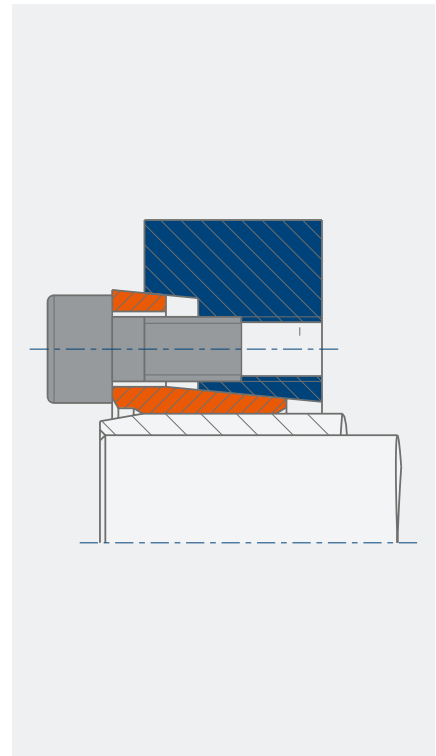

HSD with Centring Device

Connection element with centring device on the inner ring

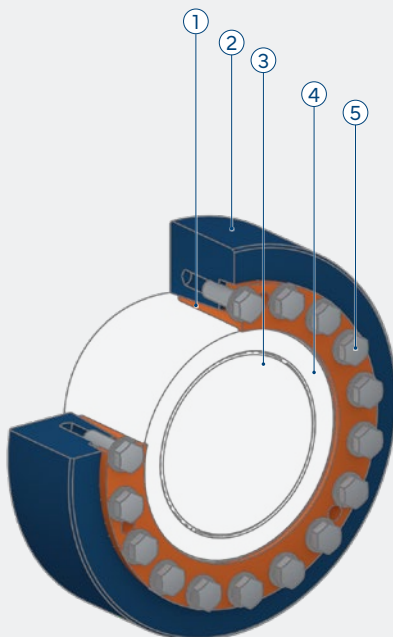

Benefits

- Easier positioning and centring
- Exact alignment is not necessary

- ① Inner ring*
- ② Outer ring*
- ③ Shaft
- ④ Hub
- ⑤ Locking bolts* including washer as necessary*

*Included with the delivery

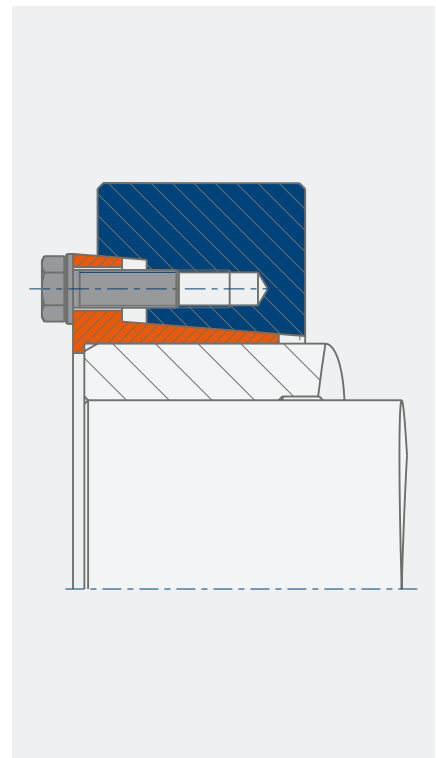

STÜWE[®]

Shrink Disc

Type SD



Shrink Disc Type SD

General Information

Application Description

In addition to the two-part HSD series STÜWE® also offers a three-part type SD shrink disc. It is characterized by its slim design while at the same time having a high level of torque transmission. The three-part torque-controlled frictional connection is maintenance-free and dirt-resistant due to its press fit and is very versatile in its use.

Areas of Use



Driveline technology



Steel- & rolling mill equipment



Crushing equipment



Conveying equipment



Agitation & mixing equipment

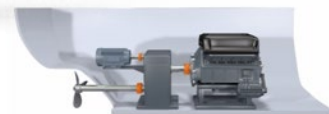

Shipbuilding

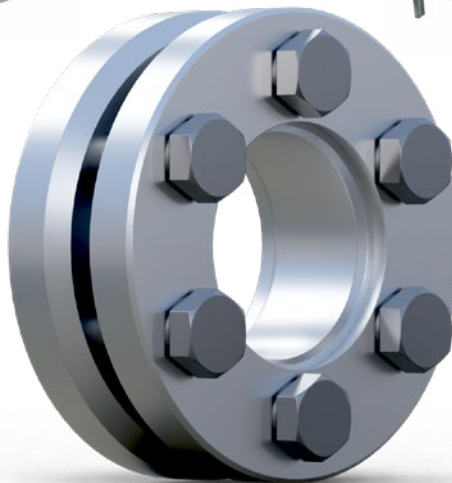

STÜWE®

Shrink Disc

Type SD – Series

Description	Shaft diameter	Transmissible torque	Features
SD 71/72	19 - 760 mm	0.28 - 8375 kNm	High torques

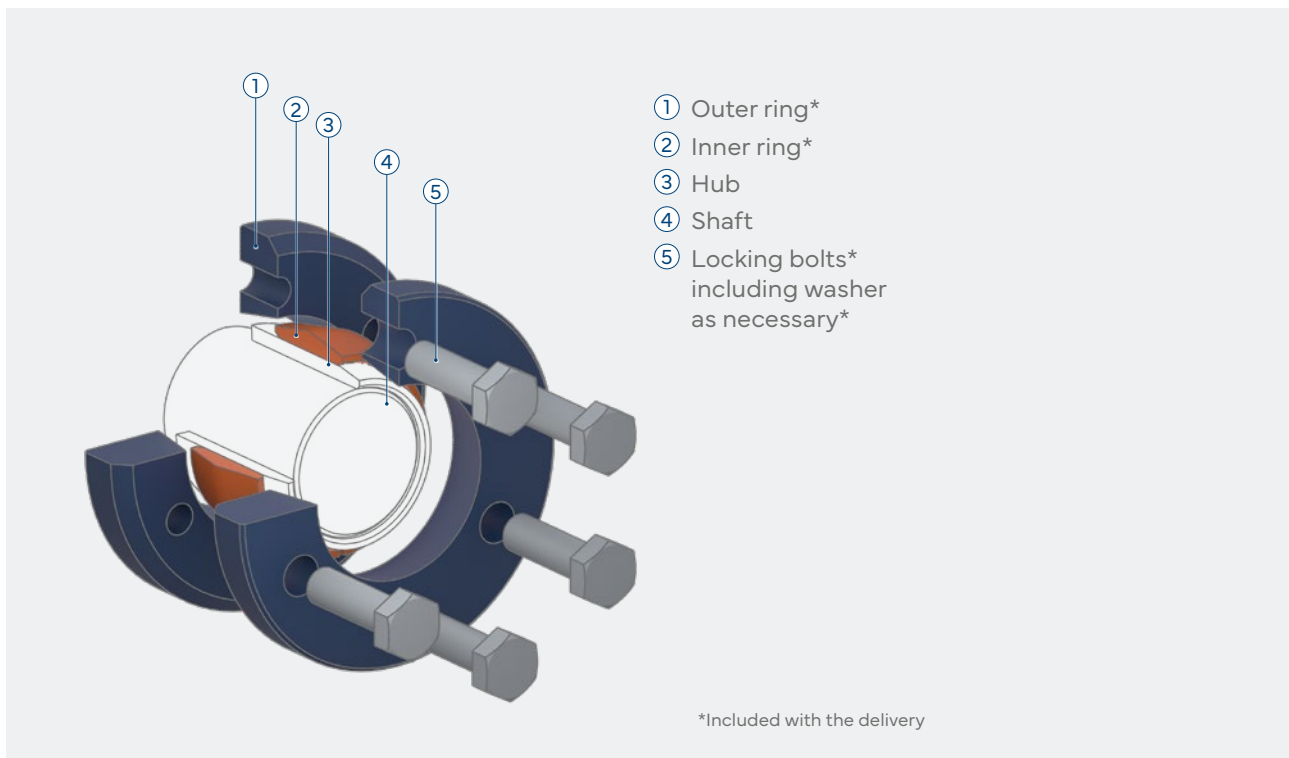

All types may be protected against environmental influences by zinc and nickel coating or by a paint which has an appropriate corrosion protection class. We are able to achieve both desired colours which conform with the RAL colour range and products with lubricants in accordance with NSF H1. More detailed information on this may be found in this catalogue on page 151.

Shrink Disc Type SD Series 71 | 72

Roughness of all mating surfaces:
Ra < 3.2 µm

Information on fits:
 $\varnothing d$: H7/f7
 $\varnothing d_w$: H7/h6 ($\varnothing d_w < 160$)
H7/g6 ($\varnothing d_w \geq 160$)

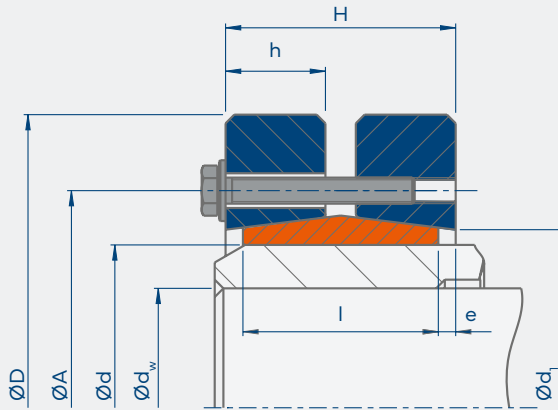

Code

M_t Maximum transmissible torque of a shrink disc for $P_{ax} = 0$

P_{ax} Maximum transmissible axial load of a shrink disc for $M_t = 0$

M_a Required tightening torque of the locking bolts (see also "Installation and Removal Instructions")

Dimensions H and e apply to untightened units.

Shrink Disc Type SD – Series 71 | 72

Type	d mm	d _w	M _t kNm	P _{ax} kN	M _a Nm	B*	D mm	l mm	h mm	H mm	A mm	d ₁ mm	e mm	kg
SD 24-72	24	19	0.28	29	5	6 x M5 x 16	50	14	7.8	19	36	26	2.5	0.2
		20	0.33	33										
		21	0.38	36										
SD 30-72	30	24	0.36	30	5	6 x M5 x 18	60	16	8.5	20	44	32	2.0	0.3
		25	0.41	33										
		26	0.46	36										
SD 36-72	36	28	0.62	44	12	5 x M6 x 20	70	18	10.0	23	52	38	2.5	0.4
		30	0.76	51										
		31	0.80	52										
SD 44-72	44	34	0.83	49	12	6 x M6 x 20	80	20	10.5	24	61	47	2.0	0.6
		35	0.91	52										
		36	0.99	55										
SD 50-72	50	38	1.4	72	12	8 x M6 x 22	90	22	11.5	26	75	53	2.0	0.8
		40	1.6	79										
		42	1.8	87										
SD 55-72	55	42	1.5	71	12	8 x M6 x 25	100	23	12.5	29	75	58	3.0	1.1
		45	1.8	81										
		48	2.2	91										
SD 62-72	62	48	2.0	85	12	9 x M6 x 25	110	23	12.5	29	86	66	3.0	1.3
		50	2.3	91										
		52	2.4	94										

Further sizes on request, subject to technical changes.

*Locking bolts: DIN EN ISO 4014/4017 grade 10.9 as standard, alternatively DIN EN ISO 4762 grade 10.9

When ordering please state: (Type x $\varnothing d$), e.g. SD-500-71x500

Shrink Disc Type SD – Series 71 | 72

Type	d mm	d _w	M _t kNm	P _{ax} kN	M _a Nm	B*	D mm	l mm	h mm	H mm	A mm	d ₁ mm	e mm	kg
SD 68-72	68	50	2.0	79	12	9 x M6 x 25	115	23	12.5	29	86	72	3.0	1.3
		55	2.5	90										
		60	3.2	106										
SD 75-72	75	55	3.4	122	29	7 x M8 x 25	138	25	13.0	31	100	79	3.0	2.3
		60	4.3	142										
		65	5.3	162										
SD 80-72	80	60	3.9	129	29	7 x M8 x 25	138	25	13.0	31	100	84	3.0	2.1
		65	4.8	147										
		70	5.8	166										
SD 90-72	90	65	5.6	172	29	10 x M8 x 30	155	30	16.5	38	114	96	4.0	3.2
		70	6.8	194										
		75	8.1	215										
SD 100-72	100	70	7.5	214	29	12 x M8 x 35	168	34	19.0	43	124	104	4.5	4.2
		75	8.9	238										
		80	10.5	262										
SD 110-72	110	75	9.1	243	58	9 x M10 x 40	185	39	21.5	49	136	115	5.0	5.8
		80	10.7	268										
		85	12.2	286										
SD 125-72	125	85	13.2	310	58	12 x M10 x 40	215	42	23.0	53	160	134	5.5	8.7
		90	15.2	338										
		95	17.4	367										
SD 140-71	140	95	19.9	419	100	10 x M12 x 50	230	46	25.0	58	176	146	6.0	10.3
		100	22.5	451										
		105	25.3	483										
SD 155-71	155	105	25.8	492	100	12 x M12 x 50	263	50	26.0	62	192	165	6.0	15.2
		110	28.9	525										
		115	32.1	558										
SD 165-71	165	115	33.7	586	240	8 x M16 x 60	290	56	29.0	66	210	174	5.0	21.5
		120	37.3	622										
		125	40.4	646										
SD 175-71	175	125	41.2	659	240	8 x M16 x 60	300	56	29.0	68	220	185	6.0	22.5
		130	45.2	695										
		135	49.4	732										
SD 185-71	185	135	56.3	834	240	10 x M16 x 65	320	71	36.0	85	236	195	7.0	32.7
		140	61.4	877										
		145	66.8	921										
SD 195-71	195	140	67.4	963	240	12 x M16 x 70	340	71	37.0	85	246	206	7.0	37.2
		150	79.1	1055										
		155	85.4	1102										
SD 200-71	200	150	80.5	1073	240	12 x M16 x 70	340	71	37.0	85	246	206	7.0	36.3
		155	86.8	1120										
		160	91.7	1147										

Further sizes on request, subject to technical changes.

*Locking bolts: DIN EN ISO 4014/4017 grade 10.9 as standard, alternatively DIN EN ISO 4762 grade 10.9

When ordering please state: (Type x Ød), e.g. SD-500-71x500

Shrink Disc Type SD – Series 71 | 72

Type	d mm	d _w	M _t kNm	P _{ax} kN	M _a Nm	B*	D mm	l mm	h mm	H mm	A mm	d ₁ mm	e mm	kg
SD 220-71	220	160	102	1276	240	15 x M16 x 80	370	88	45.0	103	276	230	7.5	53.0
		165	110	1332										
		170	118	1388										
SD 240-71	240	170	124	1462	470	11 x M20 x 90	405	92	47.0	110	296	248	9.0	66.0
		180	142	1579										
		190	159	1675										
SD 260-71	260	190	172	1812	470	12 x M20 x 90	430	103	53.0	120	321	268	8.5	82.0
		200	194	1943										
		210	218	2076										
SD 280-71	280	210	226	2153	470	15 x M20 x 100	460	114	58.0	132	346	288	9.0	103
		220	252	2292										
		230	280	2433										
SD 300-71	300	230	273	2373	470	16 x M20 x 100	485	122	60.0	138	364	308	8.0	120
		240	302	2513										
		245	316	2583										
SD 320-71	320	240	318	2646	470	18 x M20 x 100	520	122	60.0	134	386	328	6.0	138
		250	349	2791										
		260	378	2909										
SD 340-71	340	250	441	3526	470	24 x M20 x 110	570	134	69.0	156	420	348	11.0	189
		260	477	3668										
		270	520	3848										
SD 350-71	350	270	505	3742	470	24 x M20 x 110	580	140	69.0	156	432	358	8.0	196
		280	549	3920										
		285	571	4010										
SD 360-71	360	280	526	3758	470	24 x M20 x 110	590	140	73.0	161	432	367	10.5	207
		290	570	3931										
		295	593	4018										
SD 380-71	380	290	592	4081	820	18 x M24 x 130	645	144	74	164	458	387	10.0	250
		300	639	4260										
		310	688	4440										
SD 390-71	390	300	769	5124	820	20 x M24 x 120	650	144	76	170	468	397	13.0	249
		310	826	5332										
		320	882	5514										
SD 420-71	420	330	829	5026	820	20 x M24 x 130	670	164	82	184	504	428	10.0	285
		340	888	5221										
		350	948	5418										
SD 440-71	440	340	933	5488	820	24 x M24 x 130	730	172	86	192	527	450	10.0	373
		350	996	5693										
		360	1062	5898										
SD 460-71	460	360	1099	6108	820	24 x M24 x 140	760	172	86	192	547	468	10.0	402
		370	1169	6319										
		380	1241	6530										

Further sizes on request, subject to technical changes.

*Locking bolts: DIN EN ISO 4014/4017 grade 10.9 as standard, alternatively DIN EN ISO 4762 grade 10.9

When ordering please state: (Type x Ød), e.g. SD-500-71x500

Shrink Disc Type SD – Series 71 | 72

Type	d mm	d _w	M _t kNm	P _{ax} kN	M _a Nm	B*	D mm	l mm	h mm	H mm	A mm	d ₁ mm	e mm	kg
SD 480-71	480	380	1266	6661	820	28 x M24 x 140	785	188	97	213	570	490	12.5	463
		390	1341	6879										
		400	1420	7098										
SD 500-71	500	400	1710	8551	1210	24 x M27 x 150	840	188	96	214	590	508	13.0	547
		410	1796	8763										
		420	1895	9022										
SD 530-71	530	430	2102	9776	1210	30 x M27 x 160	910	213	108	238	620	540	12.5	744
		440	2211	10051										
		450	2324	10328										
SD 560-71	560	450	2195	9757	1210	30 x M27 x 160	940	213	108	238	650	568	12.5	776
		460	2304	10019										
		470	2417	10283										
SD 590-71	590	470	2732	11623	1210	36 x M27 x 180	945	228	118	260	684	600	16.0	794
		480	2860	11918										
		490	2992	12212										
SD 620-71	620	500	2961	11845	1640	30 x M30 x 190	970	254	131	288	726	630	17.0	903
		510	3077	12068										
		520	3213	12359										
SD 660-71	660	530	3428	12938	1640	30 x M30 x 190	1045	260	133	292	766	670	16.0	1090
		540	3573	13235										
		550	3721	13532										
SD 700-71	700	560	3988	14242	1640	36 x M30 x 190	1120	260	133	292	806	710	16.0	1269
		575	4226	14698										
		590	4471	15156										
SD 750-71	750	600	4766	15887	1640	40 x M30 x 200	1150	278	141	310	864	760	16.0	1350
		615	5030	16359										
		630	5302	16832										
SD 800-71	800	645	5810	18014	1640	45 x M30 x 210	1270	296	153	334	920	810	19.0	1839
		660	6111	18518										
		675	6420	19022										
SD 900-71	900	720	7439	20664	2210	40 x M33 x 240	1420	332	170	370	1030	910	19.0	2558
		740	7900	21350										
		760	8375	22040										

Further sizes on request, subject to technical changes.

*Locking bolts: DIN EN ISO 4014/4017 grade 10.9 as standard, alternatively DIN EN ISO 4762 grade 10.9

When ordering please state: (Type x Ød), e.g. SD-500-71x500

You have not found what you are looking for in our comprehensive range of standard-products?
We will be happy to promptly prepare any form of custom-made product and development innovation
even using special materials such as 1.3974. Please feel free to contact us.

Shrink Disc Type SD

Special Solutions

SD with Protection

Connection element with a protrusion on the outer ring

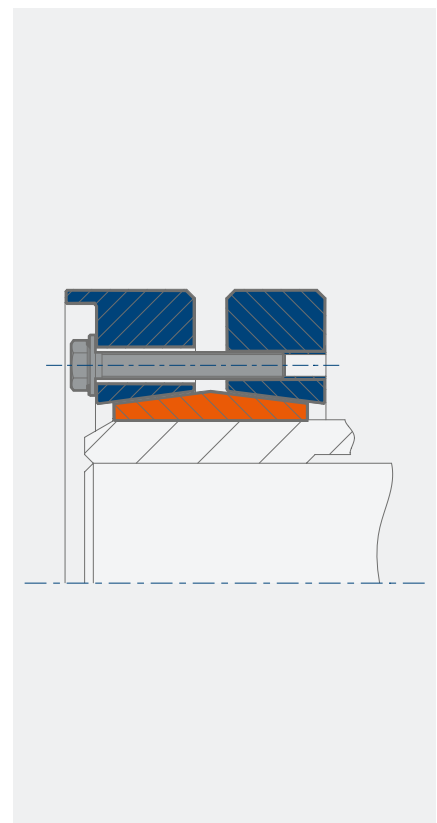
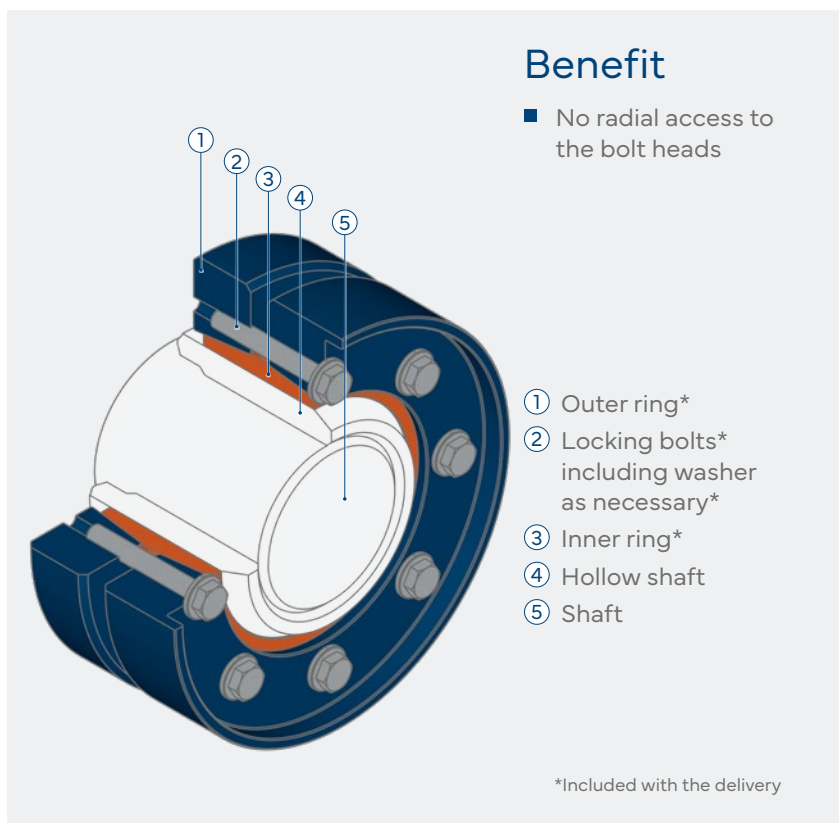

Individual solution USD

Internal locking frictional connection

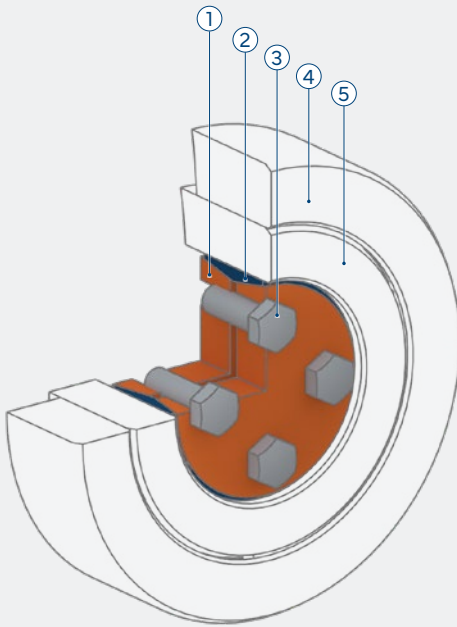

Benefits

- Less components
- Outside the flow of loads
- Alternative to UHSD
- Possible compensation of varying fitting tolerance

- ① Inner ring*
- ② Outer ring*
- ③ Locking bolts* including washer as necessary*
- ④ Hub
- ⑤ Shaft

*Included with the delivery

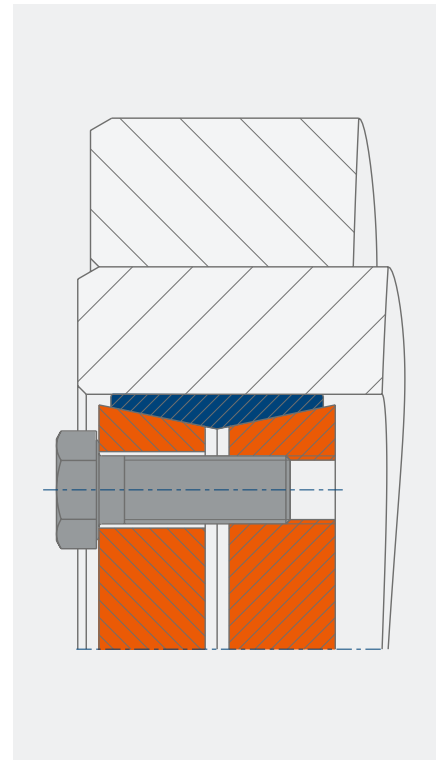

Individual solution SDB

Connection element for particularly compact installation spaces

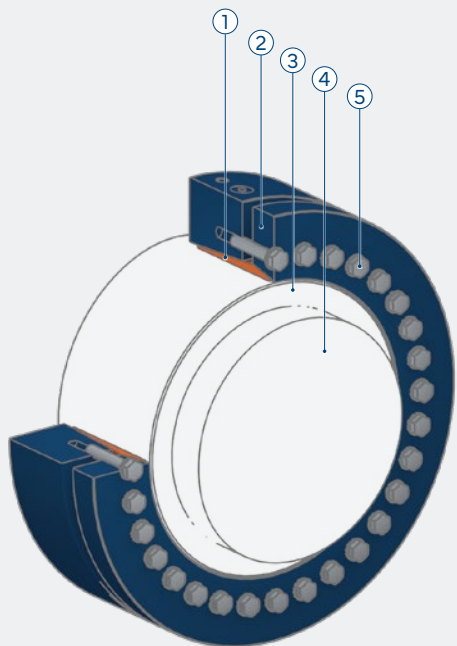

Benefits

- Reduced width in non-tensioned condition
- Smaller protrusion on one side
- Compact design for limited width

- ① Inner ring*
- ② Outer ring*
- ③ Hub
- ④ Shaft
- ⑤ Locking bolts* including washer as necessary*

*Included with the delivery

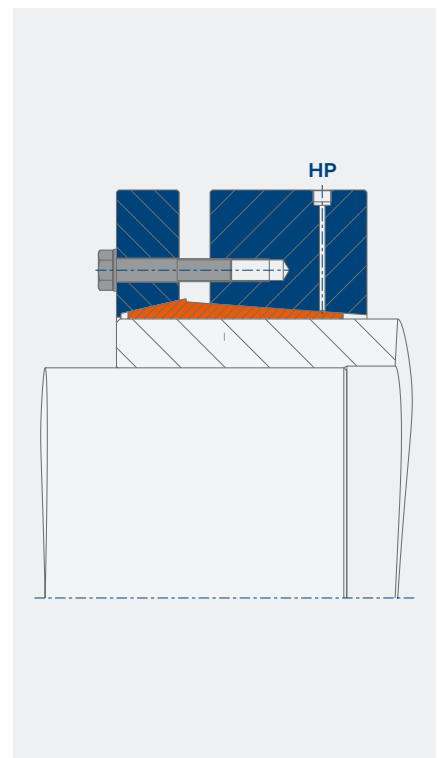

STÜWE[®]

Shrink Disc

Type HYD – Hydraulic



Shrink Disc Type HYD

General Information

Application Description

The hydraulic shrink disc type HYD is based on the same principle as the type HSD mechanical shrink disc. As a result of the hydraulic tensioning only a fraction of the time is required for installation and removal compared with the mechanical type HSD.

Areas of Use



Driveline technology

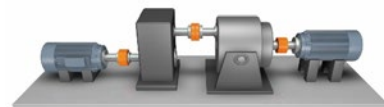

Measurement & testing equipment



Crushing equipment



Conveying equipment



Agitation & mixing equipment



Wind turbines

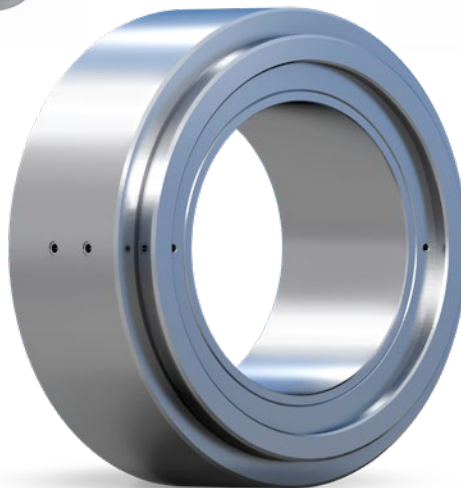



Shrink Disc

Type HYD – Series

Description	Shaft diameter	Transmissible torque	Features
HYD 12	90 - 680 mm	16 - 6211 kNm	average torques, compact series
HYD 22	50 - 860 mm	2.7 - 12349 kNm	high torques

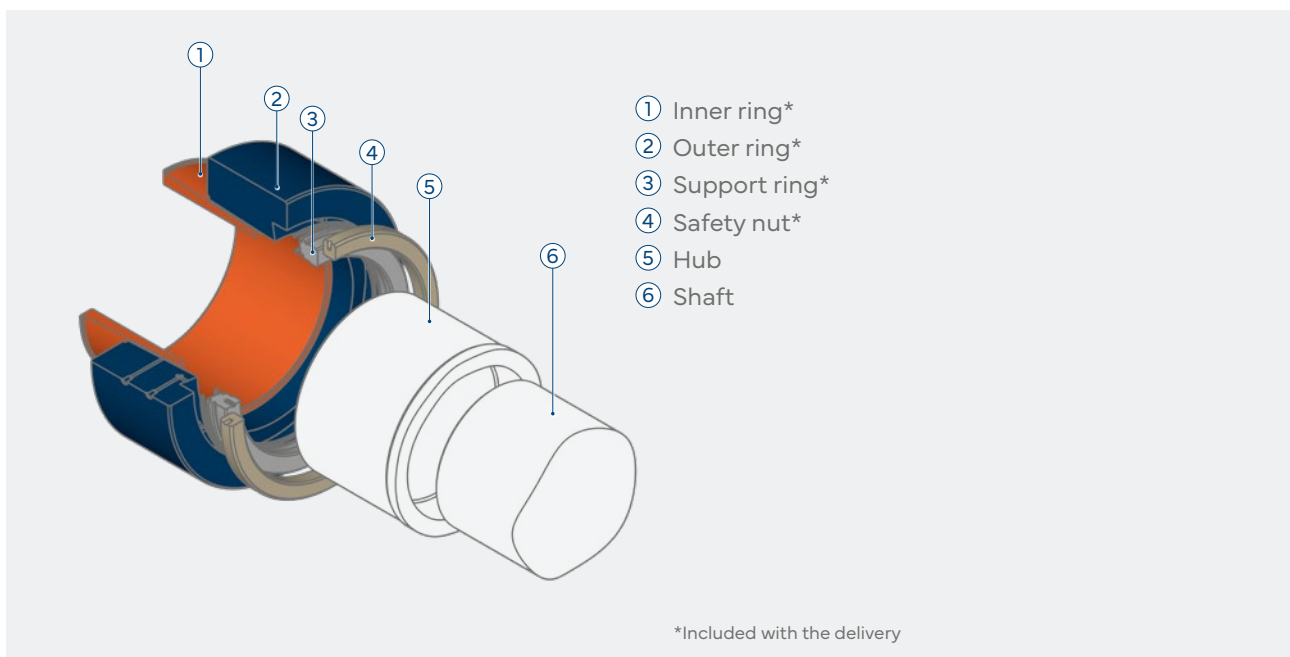

All types may be protected against environmental influences by zinc and nickel coating or by a paint which has an appropriate corrosion protection class. We are able to achieve both desired colours which conform with the RAL colour range and products with lubricants in accordance with NSF H1. More detailed information on this may be found in this catalogue on page 151.

Shrink Disc Type HYD Series 12

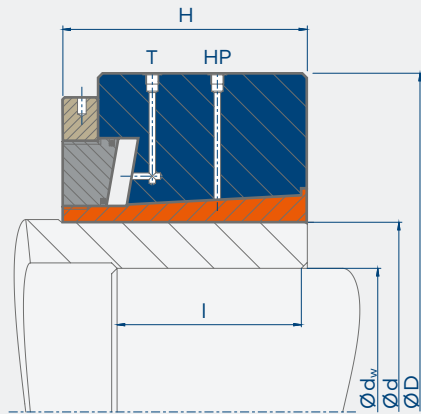

Information on fits:
 $\varnothing d_w$: H7/h6 ($\varnothing d_w < 160$)
 H7/g6 ($\varnothing d_w \geq 160$)
 $\varnothing d$: H7/f7

Roughness of all mating surfaces:
 $R_a < 3.2 \mu\text{m}$

Code

- M_t Maximum transmissible torque of a shrink disc for $P_{ax} = 0$
- P_{ax} Maximum transmissible axial load of a shrink disc for $M_t = 0$
- HP High pressure is a maximum of 3800 bar
- T Clamping pressure is a maximum of 450 bar

Shrink Disc Type HYD – Series 12

Type	d mm	d _w mm	M _t kNm	P _{ax} kN	D mm	l mm	H mm	kg
HYD 125 - 12	125	90	16	348	215	42	75	13
		95	18	377				
		100	20	406				
HYD 140 - 12	140	100	19	374	245	46	84	20
		105	21	401				
		110	24	429				
HYD 155 - 12	155	110	27	488	263	50	90	23
		115	30	520				
		120	33	551				
HYD 165 - 12	165	120	36	592	290	56	90	29
		125	39	628				
		130	43	663				
HYD 175 - 12	175	130	50	776	300	56	90	31
		135	55	818				
		140	60	861				
HYD 185 - 12	185	140	62	881	320	71	117	46
		145	67	924				
		150	73	968				
HYD 200 - 12	200	150	73	976	340	71	117	51
		160	85	1064				
		165	91	1108				
HYD 220 - 12	220	160	96	1194	370	80	130	66
		170	110	1297				
		180	126	1401				
HYD 240 - 12	240	180	140	1560	430	86	150	110
		190	159	1677				
		200	180	1796				
HYD 260 - 12	260	200	180	1795	430	95	145	98
		210	201	1916				
		220	224	2038				
HYD 280 - 12	280	220	228	2073	460	100	150	115
		230	253	2198				
		240	279	2323				

When ordering please state: (Type x $\varnothing d$) e.g. HYD

Shrink Disc Type HYD – Series 12

Type	d mm	d _w mm	M _t kNm	P _{ax} kN	D mm	I mm	H mm	kg
HYD 300 - 12	300	230	258	2242	485	110	160	134
		240	285	2371				
		250	313	2501				
HYD 320 - 12	320	250	348	2781	520	120	179	173
		260	381	2929				
		270	415	3077				
HYD 340 - 12	340	260	398	3063	570	120	179	216
		270	434	3215				
		280	472	3369				
HYD 360 - 12	360	280	467	3334	590	120	179	225
		350	505	3486				
		300	546	3638				
HYD 390 - 12	390	310	617	3978	650	135	200	311
		380	663	4143				
		330	711	4308				
HYD 420 - 12	420	330	718	4353	690	135	200	345
		340	768	4519				
		350	820	4686				
HYD 440 - 12	440	340	836	4917	720	160	240	449
		350	893	5100				
		360	951	5284				
HYD 460 - 12	460	360	944	5246	745	160	240	475
		370	1004	5429				
		380	1066	5612				
HYD 480 - 12	480	380	1221	6425	780	170	260	566
		390	1293	6631				
		400	1368	6839				
HYD 500 - 12	500	400	1335	6674	830	170	260	657
		410	1411	6881				
		420	1488	7088				
HYD 530 - 12	530	430	1524	7088	850	190	280	712
		440	1605	7294				
		450	1688	7501				
HYD 560 - 12	560	450	1673	7435	880	190	280	743
		460	1757	7640				
		470	1844	7846				
HYD 590 - 12	590	470	1987	8456	940	200	300	925
		480	2082	8676				
		490	2179	8896				
HYD 620 - 12	620	500	2236	8945	965	210	310	976
		510	2337	9166				
		520	2441	9389				
HYD 660 - 12	660	530	2728	10294	1040	210	310	1153
		540	2843	10529				
		550	2960	10764				
HYD 700 - 12	700	560	3278	11708	1100	220	320	1327
		580	3540	12207				
		600	3812	12708				
HYD 750 - 12	750	600	4555	15184	1260	240	350	2066
		620	4889	15772				
		640	5236	16361				
HYD 800 - 12	800	640	5446	17019	1310	260	370	2293
		660	5822	17642				
		680	6211	18267				

Further sizes on request, subject to technical changes.

When ordering please state: (Type x Ød) e.g. HYD 560 - 12 x 560

Shrink Disc Type HYD Series 22

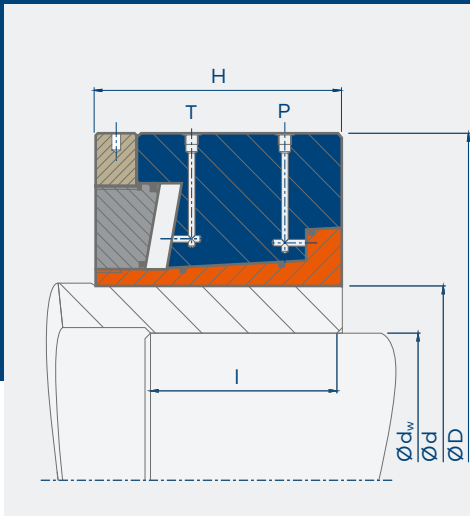

Information on fits:
 $\varnothing d_w$: H7/h6 ($\varnothing d_w < 160$)
 H7/g6 ($\varnothing d_w \geq 160$)
 $\varnothing d$: H7/f7

Roughness of all mating surfaces:
 $R_a < 3.2 \mu\text{m}$

Code

- M_t Maximum transmissible torque of a shrink disc for $P_{ax} = 0$
- P_{ax} Maximum transmissible axial load of a shrink disc for $M_t = 0$
- P Release pressure is a maximum of 450 bar
- T Clamping pressure is a maximum of 450 bar

Shrink Disc Type HYD – Series 22

Type	d mm	d _w mm	M _t kNm	P _{ax} kN	D mm	I mm	H mm	kg
HYD 62 - 22	62	50	2.7	107	130	33	60	5
		52	3.0	114				
		53	3.1	118				
HYD 80 - 22	80	55	3.1	112	155	33	60	6
		60	3.9	130				
		65	4.8	148				
HYD 100 - 22	100	70	7.6	217	185	45	70	10
		75	9.0	241				
		80	10.6	265				
HYD 125 - 22	125	90	18	390	230	45	75	16
		95	20	421				
		100	23	453				
HYD 140 - 22	140	100	25	495	263	50	84	24
		105	28	529				
		110	31	563				
HYD 155 - 22	155 150	110	33	592	300	50	90	34
		115	36	628				
		120	40	663				
HYD 165 - 22	165	120	40	667	320	53	102	44
		125	44	706				
		130	48	744				
HYD 175 - 22	175	130	50	770	320	53	102	42
		135	55	810				
		140	59	850				
HYD 185 - 22	185	140	74	1056	340	71	117	55
		145	80	1106				
		150	87	1155				
HYD 200 - 22	200	150	86	1151	370	71	117	65
		160	100	1249				
		165	107	1299				
HYD 220 - 22	220	160	105	1311	405	88	140	93
		170	121	1425				
		180	139	1540				

When ordering please state: (Type x $\varnothing d$) e.g. HYD

Shrink Disc Type HYD – Series 22

Type	d mm	d _w mm	M _t kNm	P _{ax} kN	D mm	l mm	H mm	kg
HYD 240 - 22	240	180	145	1615	430	88	143	105
		190	165	1737				
		200	186	1861				
HYD 260 - 22	260	200	199	1988	460	100	160	142
		210	223	2123				
		220	249	2259				
HYD 280 - 22	280	220	285	2587	485	122	180	174
		230	315	2741				
		240	348	2896				
HYD 300 - 22	300	230	326	2833	520	120	190	198
		240	359	2991				
		250	394	3149				
HYD 320 - 22	320	250	397	3175	570	140	220	285
		260	434	3342				
		270	474	3510				
HYD 340 - 22	340	260	541	4162	640	140	220	374
		270	589	4363				
		280	639	4565				
HYD 360 - 22	360	280	646	4615	660	140	220	388
		350	699	4815				
		300	753	5022				
HYD 390 - 22	390	310	791	5101	690	140	220	412
		380	849	5304				
		330	909	5508				
HYD 420 - 22	420	330	850	5152	720	178	255	506
		340	910	5352				
		350	972	5552				
HYD 440 - 22	440	340	915	5384	740	168	255	530
		350	977	5584				
		360	1041	5785				
HYD 460 - 22	460	360	1016	5645	760	165	255	540
		370	1081	5842				
		380	1147	6039				
HYD 480 - 22	480	380	1386	7293	830	188	295	785
		390	1468	7526				
		400	1552	7760				
HYD 500 - 22	500	400	1720	8600	850	188	295	810
		410	1816	8859				
		420	1915	9118				
HYD 530 - 22	530	430	2141	9958	910	223	330	1045
		440	2252	10236				
		450	2366	10515				
HYD 560 - 22	560	450	2397	10653	980	223	330	1240
		460	2515	10934				
		470	2636	11216				
HYD 590 - 22	590	470	2726	11600	1020	230	360	1445
		480	2854	11892				
		490	2985	12185				
HYD 620 - 22	620	500	3203	12810	1070	230	360	1595
		510	3345	13119				
		520	3491	13428				
HYD 660 - 22	660	530	4079	15393	1160	245	380	2005
		540	4248	15734				
		550	4421	16076				
HYD 700 - 22	700	560	4501	16073	1210	260	420	2345
		580	4857	16749				
		600	5228	17428				

When ordering please state: (Type x Ød) e.g. HYD 390 - 22 x 380

Shrink Disc Type HYD – Series 22

Type	d mm	d _w mm	M _t kNm	P _{ax} kN	D mm	I mm	H mm	kg
HYD 750 - 22	750	580	4808	16579	1260	300	450	2615
		590	4990	16916				
		600	5176	17255				
HYD 775 - 22	775	610	5521	18101	1300	310	470	2948
		620	5719	18449				
		630	5921	18798				
HYD 800 - 22	800	640	6255	19546	1350	320	490	3280
		660	6690	20273				
		680	7141	21003				
HYD 850 - 22	850	680	7542	22183	1430	340	520	3840
		690	7786	22568				
		700	8033	22953				
HYD 900 - 22	900	700	8443	24123	1520	360	550	4752
		710	8707	24526				
		730	9247	25334				
HYD 950 - 22	950	740	10034	27119	1590	380	580	5429
		750	10329	27544				
		800	11871	29677				
HYD 1000 - 22	1000	820	12680	30927	1650	400	600	5951
		830	13018	31369				
		850	13708	32254				
HYD 1025 - 22	1025	840	13603	32388	1700	410	620	6567
		850	13956	32838				
		860	14314	33288				

Further sizes on request, subject to technical changes.

When ordering please state: (Type x Ød) e.g. HYD 900 - 22 x 900

You have not found what you are looking for in our comprehensive range of standard-products? We will be happy to promptly prepare any form of custom-made product and development innovation even using special materials such as 1.3974. Please feel free to contact us.

Shrink Disc Type HYD

Special Solutions

HYD for Test Beds

Connection element for extremely high numbers of cycles

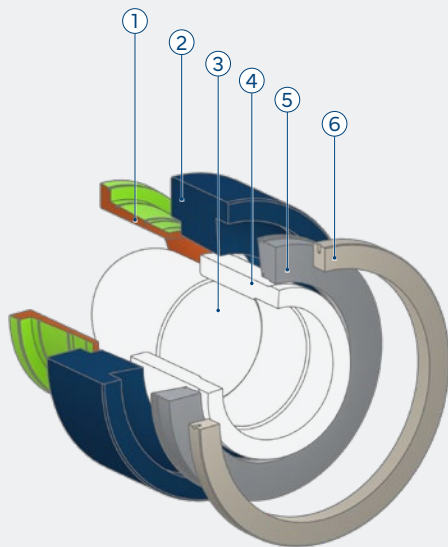

Benefits

- Smaller installation space
- Greater freedom for design
- Outside the flow of loads

- ① Inner ring*
- ② Outer ring*
- ③ Hub
- ④ Shaft
- ⑤ Support ring*
- ⑥ Nut*

*Included with the delivery

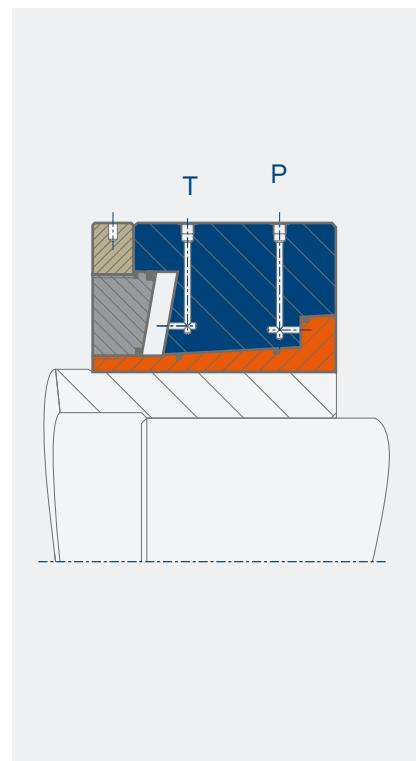

Individual solution HYSD

Hydraulic connection element for particularly compact installation spaces

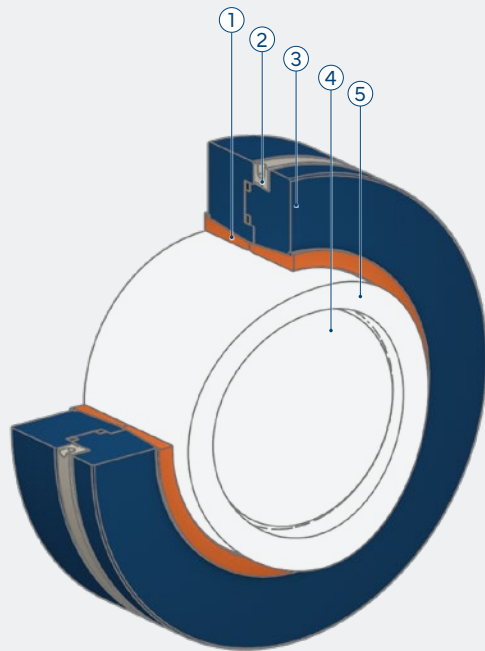

Benefits

- Less components
- Easier and safer installation

- ① Inner ring*
- ② Nut*
- ③ Outer ring*
- ④ Shaft
- ⑤ Hub

*Included with the delivery

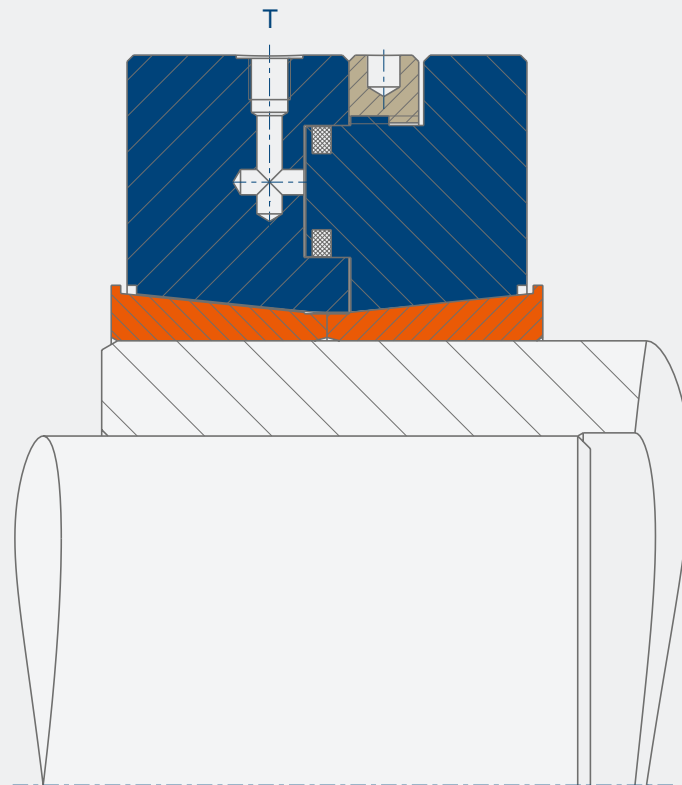

STÜWE[®]

Shrink Disc

Type SDG and SDGH



Shrink Disc SDG and SDGH

General Information

Application Description

The divided type SDG shrink discs are four-part shrink discs which are used for the space-saving shrinking of disc-shaped components such as gearwheels, pulleys or cams. This is frequently used where particularly low space for installation exists. If only a single-sided connection is needed, STÜWE® offers the divided type SDGH shrink disc.

Areas of Use



Driveline technology



Steel- & rolling mill equipment



Crushing equipment



Conveying equipment



Pulley



Gearbox



Shrink Disc

Type SDG and SDGH – Series

Description	Shaft diameter	Transmissible torque	Features
SDG 71/72	19 - 470 mm	0.26 - 2386 kNm	High torques
SDG 91	95 - 320 mm	23 - 919 kNm	Extremely high torques

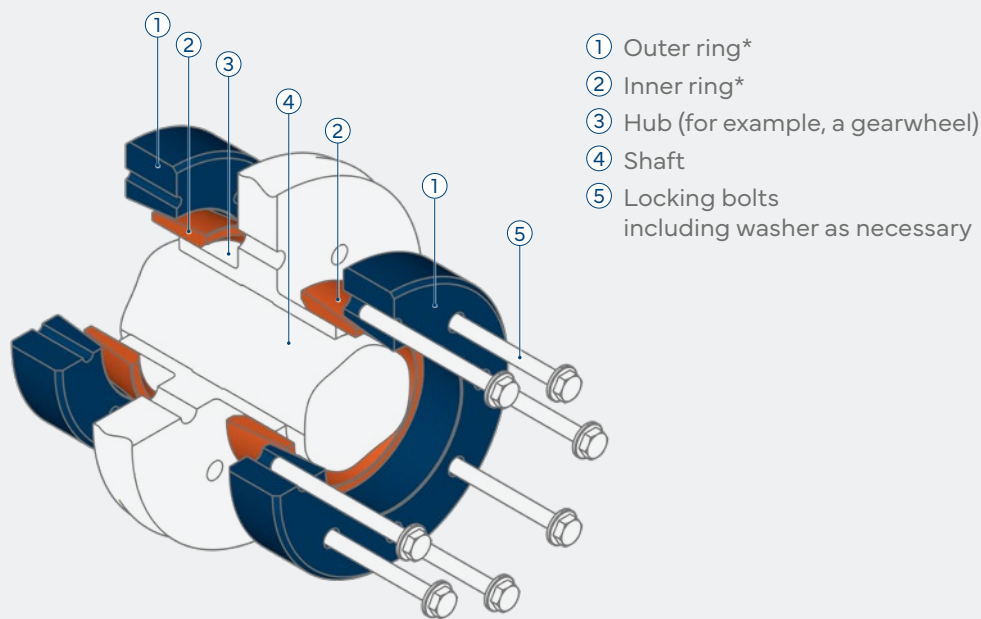

*Included with the delivery

All types may be protected against environmental influences by zinc and nickel coating or by a paint which has an appropriate corrosion protection class. We are able to achieve both desired colours which conform with the RAL colour range and products with lubricants in accordance with NSF H1. More detailed information on this may be found in this catalogue on page 151.

Shrink Disc Type SDG Series 71 | 72

Roughness of all mating surfaces:
Ra < 3.2 µm

Information on fits:
 $\varnothing d$: H7/f7
 $\varnothing d_w$: H7/h6 ($\varnothing d_w < 160$)
H7/g6 ($\varnothing d_w \geq 160$)

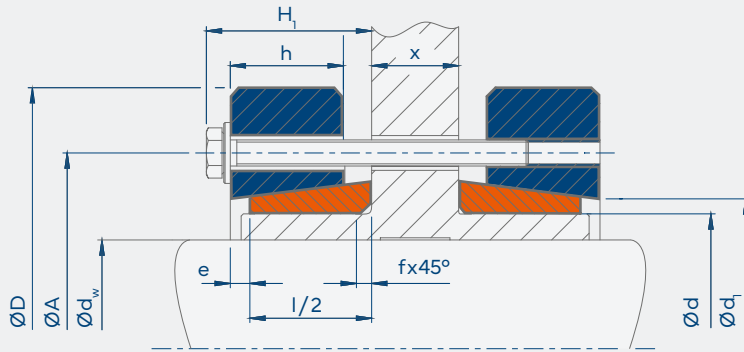

Code

M_t Maximum transmissible torque of a shrink disc for $P_{ax} = 0$

P_{ax} Maximum transmissible axial load of a shrink disc for $M_t = 0$

M_a Required tightening torque of the locking bolts (see also "Installation and Removal Instructions")

Dimensions H_1 and e apply to untightened units.

Shrink Disc Type SDG – Series 71 | 72

Type	d mm	d _w mm	M _t kNm	P _{ax} kN	M _a Nm	Locking bolts*	D mm	l/2 mm	h mm	H ₁ mm	A mm	d ₁ mm	e mm	f mm	kg
SDG 24 - 72	24	19	0.26	28	5	6 x M5	50	9	7.8	16	36	25.5	4	1.5	0.2
		20	0.31	31											
		21	0.36	34											
SDG 30 - 72	30	24	0.34	28	5	6 x M5	60	10	8.5	17	44	32	4	1.5	0.3
		25	0.39	31											
		26	0.44	34											
SDG 36 - 72	36	28	0.61	44	12	5 x M6	70	11	10	19	52	38	4	2	0.5
		30	0.76	50											
		33	1.00	60											
SDG 44 - 72	44	34	0.83	49	12	6 x M6	80	12	10.5	20	61	46.5	4	2	0.6
		35	0.91	52											
		36	1.00	55											
SDG 50 - 72	50	38	1.4	72	12	8 x M6	90	13	11.5	20	75	52.5	3	2.5	0.8
		40	1.6	79											
		42	1.8	87											
SDG 55 - 72	55	42	1.5	71	12	8 x M6	100	14	12.5	23	75	57.5	5	2.5	1.1
		45	1.8	81											
		48	2.2	92											
SDG 62 - 72	62	48	2.0	85	12	9 x M6	110	14	12.5	23	86	65	5	2.5	1.3
		50	2.3	92											
		52	2.6	98											
SDG 68 - 72	68	50	2.0	79	12	9 x M6	115	14	12.5	23	86	71	5	2.5	1.4
		55	2.6	94											
		60	3.3	110											

*Locking bolts: standard DIN EN ISO 4014/4017 Grade 10.9, alternative DIN EN ISO 4762 Grade 10.9
M16 and upwards with washers: DIN EN ISO 7416

Dimension X is specified by the customer and determines the bolt length

When ordering please state: (Type x $\varnothing d$) Dimension X, e.g. SDG 62 - 72 x 62 x=15 mm

Shrink Disc Type SDG – Series 71 | 72

Type	d mm	d _w mm	M _t kNm	P _{ax} kN	M _a Nm	Locking bolts*	D mm	l/2 mm	h mm	H ₁ mm	A mm	d ₁ mm	e mm	f mm	kg
SDG 80 - 72	80	60	3.8	128	29	7 x M8	138	17	13	27	100	83.5	5	4	2.5
	75	65	4.8	147											
		70	5.8	165											
SDG 90 - 72	90	65	5.8	178	29	10 x M8	155	20	16.5	31	114	96	6	5	3.7
	85	70	7.0	200											
		75	8.4	223											
SDG 100 - 72	100	70	7.3	209	29	12 x M8	168	24.3	19	32	124	104	2	5	4.9
	95	75	8.7	233											
		80	10.3	257											
SDG 110 - 72	110	80	10.5	261	58	9 x M10	185	24	21.5	37	136	115	7	5	6.2
	105	85	12.2	288											
		90	14.2	315											
SDG 125 - 72	125	90	15.0	333	58	12 x M10	215	26	23	39	160	134	7	5	9.3
	120	95	17.1	361											
	130	100	19.5	389											
SDG 140 - 71	140	95	19.3	407	100	10 x M12	230	28	25	43	176	146	8	5	12
	135	105	24.6	469											
		110	27.6	501											
SDG 155 - 71	155	110	28.0	510	100	12 x M12	263	30	26	45	192	165	8	5	16
	150	115	31.2	542											
	160	120	34.5	575											
SDG 165 - 71	160	120	40	669	240	8 x M16	290	33	29	54	210	174	7	5	22
	165	125	44	707											
	170	130	49	747											
SDG 175 - 71	175	130	45	695	240	8 x M16	300	33	29	54	220	185	7	5	23
	180	135	49	732											
		140	54	770											
SDG 185 - 71	185	140	62	885	240	10 x M16	320	40	36	63	236	195	9	5	32
	190	145	67	929											
		150	73	973											
SDG 200 - 71	200	150	82	1088	240	12 x M16	340	40	37	63	246	206	9	5	39
	195	155	88	1136											
		160	95	1184											
SDG 220 - 71	220	160	102	1276	240	15 x M16	370	52	45	77	276	230	11	8	54
		165	110	1332											
		170	118	1388											
SDG 240 - 71	240	170	125	1474	470	11 x M20	405	46	47	72	295	248	11	8	60
		180	143	1591											
		190	162	1710											
SDG 260 - 71	260	190	173	1824	470	12 x M20	430	59	53	84	321	268	9	8	81
		200	196	1957											
		210	219	2090											
SDG 280 - 71	280	210	228	2168	470	15 x M20	460	67	58	95	346	288	12	10	104
		220	254	2308											
		230	282	2449											
SDG 300 - 71	300	220	247	2250	470	16 x M20	485	71	60	97	364	308	10	10	120
		230	275	2389											
		240	304	2529											
SDG 320 - 71	320	240	316	2631	470	18 x M20	520	71	60	97	386	328	10	10	139
		250	347	2779											
		260	381	2928											

*Locking bolts: standard DIN EN ISO 4014/4017 Grade 10.9, alternative DIN EN ISO 4762 Grade 10.9
M16 and upwards with washers: DIN EN ISO 7416

When ordering please state: (Type x Ød) Dimension X, e.g. SDG 200 - 71 x 200 X=40 mm

Shrink Disc Type SDG – Series 71 | 72

Type	d mm	d _w mm	M _t kNm	P _{ax} kN	M _a Nm	Locking bolts*	D mm	l/2 mm	h mm	H ₁ mm	A mm	d ₁ mm	e mm	f mm	kg
SDG 340 - 71	340	250	439	3511	470	24 x M20	570	77	69	103	420	348	10	10	188
		260	480	3691											
		270	523	3873											
SDG 360 - 71	360	270	485	3593	470	24 x M20	590	80	73	107	432	367	11	10	204
		280	527	3765											
		290	571	3939											
SDG 390 - 71	390	290	696	4798	820	20 x M24	650	85	76	113	468	397	9	13	268
		300	751	5005											
		310	808	5213											
SDG 420 - 71	420	320	763	4768	820	20 x M24	670	95	82	123	504	428	9	13	302
		330	818	4960											
		340	876	5153											
SDG 440 - 71	440	340	927	5456	820	24 x M24	730	99	86	128	527	450	10	13	409
		350	990	5660											
		360	1056	5864											
SDG 460 - 71	460	360	1085	6028	820	24 x M24	760	99	86	127	547	468	9	13	441
		370	1154	6237											
		380	1225	6447											
SDG 480 - 71	480	380	1257	6618	820	28 x M24	785	109	97	143	570	490	15	15	521
		390	1333	6835											
		400	1411	7053											
SDG 500 - 71	500	400	1521	7603	1100	24 x M27	850	109	96	145	590	508	14	15	601
		410	1607	7839											
		420	1696	8076											
SDG 530 - 71	530	430	2086	9704	1100	30 x M27	910	122	108	156	620	538	12	15	779
		440	2195	9978											
		450	2307	10253											
SDG 560 - 71	560	450	2167	9631	1100	30 x M27	940	122	108	156	650	568	12	15	811
		460	2275	9891											
		470	2386	10152											

Further sizes on request, subject to technical changes.

*Locking bolts: standard DIN EN ISO 4014/4017 Grade 10.9, alternative DIN EN ISO 4762 Grade 10.9
M16 and upwards with washers: DIN EN ISO 7416

When ordering please state: (Type x Ød) Dimension X, e.g. SDG 560 - 71 x 560 x=110 mm

Shrink Disc Type SDG Series 91

Roughness of all mating surfaces:
Ra < 3.2 µm

Information on fits:
 $\varnothing d$: H7/f7
 $\varnothing d_w$: H7/h6 ($\varnothing d_w < 160$)
H7/g6 ($\varnothing d_w \geq 160$)

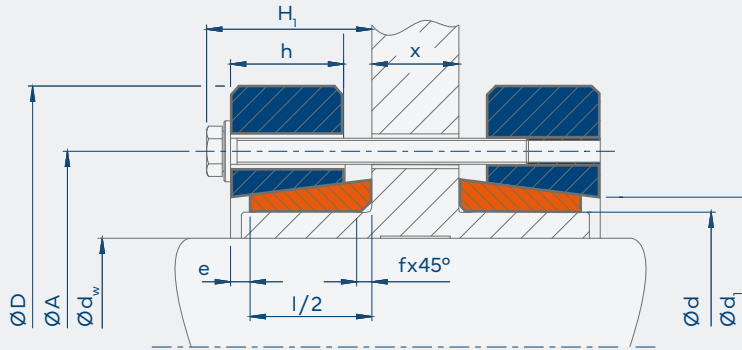

Code

M_t Maximum transmissible torque of a shrink disc for $P_{ax} = 0$

P_{ax} Maximum transmissible axial load of a shrink disc for $M_t = 0$

M_a Required tightening torque of the locking bolts (see also "Installation and Removal Instructions")

Dimensions H_1 and e apply to untightened units.

Shrink Disc Type SDG – Series 91

Type	d mm	d _w mm	M _t kNm	P _{ax} kN	M _a Nm	Locking bolts*	D mm	l/2 mm	h mm	H ₁ mm	A mm	d ₁ mm	e mm	f mm	kg
SDG 140 - 91	140	95	23	476	100	12 x M12	230	35	32	51	175	145	9	5	14
		100	26	514											
		110	32	591											
SDG 155 - 91	155	110	34	618	100	15 x M12	263	38	35	54	198	165	9	5	20
		160	38	659											
		120	42	699											
SDG 165 - 91	165	120	49	818	240	10 x M16	290	41	38	64	210	176	9	5	27
		170	54	866											
		130	59	915											
SDG 175 - 91	175	130	55	852	240	10 x M16	300	41	38	65	220	186	10	5	28
		180	61	898											
		140	66	944											
SDG 185 - 91	185	140	93	1329	240	15 x M16	320	50	50	76	236	189	12	5	41
		145	101	1392											
		150	109	1456											
SDG 200 - 91	200	150	105	1393	240	15 x M16	340	51	50	76	246	205	11	5	45
		195	113	1455											
		160	121	1517											
SDG 220 - 91	220	160	140	1744	240	20 x M16	370	65	57	90	270	225	11	8	67
		165	150	1820											
		170	161	1895											
SDG 240 - 91	240	170	172	2025	470	15 x M20	405	68	65	98	295	246	14	8	84
		180	197	2184											
		190	223	2345											
SDG 260 - 91	260	190	205	2162	470	16 x M20	430	75.5	72	105	321	266	13	8	104
		200	232	2323											
		210	261	2486											

*Locking bolts: standard DIN EN ISO 4014/4017 Grade 10.9, alternative DIN EN ISO 4762 Grade 10.9

M16 and upwards with washers: DIN EN ISO 7416

Dimension X is specified by the customer and determines the bolt length

When ordering please state: (Type x Ød) Dimension X, e.g. SDG 260 - 91 x 260 X=70 mm

Shrink Disc Type SDG – Series 91

Type	d mm	d _w mm	M _t kNm	P _{ax} kN	M _a Nm	Locking bolts*	D mm	l/2 mm	h mm	H ₁ mm	A mm	d ₁ mm	e mm	f mm	kg
SDG 280 - 91	280	210	301	2870	470	20 x M20	460	84	78	114	340	285	14	10	131
		220	336	3054											
		230	373	3239											
SDG 300 - 91	300	220	307	2790	470	20 x M20	485	86	80	116	364	309	14	10	146
		230	341	2962											
		240	376	3137											
SDG 320 - 91	320	240	422	3518	470	24 x M20	520	90	82	118	386	329	12	10	176
		250	464	3710											
		260	507	3903											
SDG 340 - 91	340	250	515	4118	820	20 x M24	570	98	92	131	420	348	14	10	239
		260	564	4335											
		270	615	4554											
SDG 360 - 91	360	270	571	4232	820	20 x M24	590	100	92	131	432	365	12	10	255
		350	622	4440											
		290	674	4648											
SDG 390 - 91	390	300	793	5289	820	24 x M24	660	107	96	140	468	401	14	13	361
		380	855	5514											
		320	919	5741											

Further sizes on request, subject to technical changes.

*Locking bolts: standard DIN EN ISO 4014/4017 Grade 10.9, alternative DIN EN ISO 4762 Grade 10.9
M16 and upwards with washers: DIN EN ISO 7416

When ordering please state: (Type x Ød) Dimension X, e.g. SDG 390 - 91 x 390 x=120 mm

Shrink Disc Type SDGH Series 71 | 72

Roughness of all mating surfaces:
Ra < 3.2 µm

Information on fits:
Ød: H7/f7
Ød_w: H7/h6 (Ød_w < 160)
H7/g6 (Ød_w ≥ 160)

Code

- M_t** Maximum transmissible torque of a shrink disc for P_{ax} = 0
- P_{ax}** Maximum transmissible axial load of a shrink disc for M_t = 0
- M_a** Required tightening torque of the locking bolts (see also "Installation and Removal Instructions")

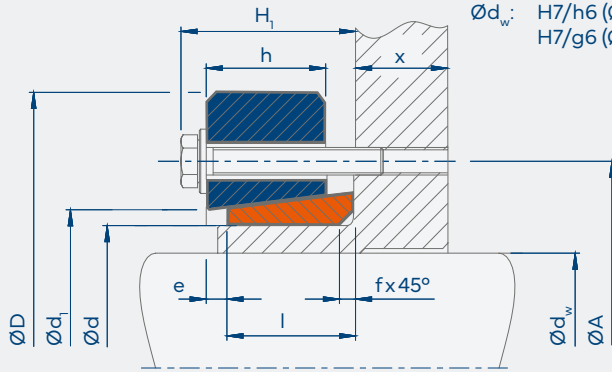

all models:
X > 1.4 x bolt-Ø

Model A

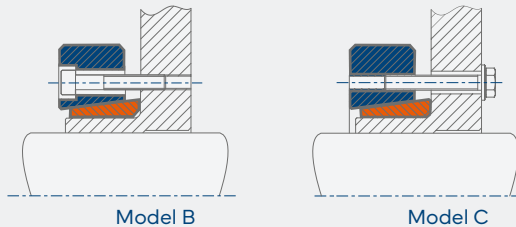

Model B

Model C

Dimensions H₁ and e apply to untightened units.

Shrink Disc Type SDGH – Series 71 | 72

Type	d mm	d _w mm	M _t kNm	P _{ax} kN	M _a Nm	Locking bolts*	D mm	l/2 mm	h mm	H ₁ mm	A mm	d ₁ mm	e mm	f mm	kg
SDGH 24 - 72	24	19	0.13	14	5	6 x M5	50	9	7.8	16	36	25.5	4	1.5	0.1
		20	0.16	16											
		21	0.18	17											
SDGH 30 - 72	30	24	0.17	14	5	6 x M5	60	10	8.5	17	44	32	4	1.5	0.2
		25	0.19	15											
		26	0.22	17											
SDGH 36 - 72	36	28	0.30	22	12	5 x M6	70	11	10	19	52	38	4	2	0.3
		30	0.38	25											
		33	0.50	30											
SDGH 44 - 72	44	34	0.41	24	12	6 x M6	80	12	10.5	20	61	46.5	4	2	0.3
		35	0.45	26											
		36	0.50	27											
SDGH 50 - 72	50	38	0.7	36	12	8 x M6	90	13	11.5	20	75	52.5	3	2.5	0.4
		40	0.8	39											
		42	0.9	43											
SDGH 55 - 72	55	42	0.7	35	12	8 x M6	100	14	12.5	23	75	57.5	5	2.5	0.6
		45	0.9	40											
		48	1.1	46											

*Locking bolts: standard DIN EN ISO 4014/4017 Grade 10.9, alternative DIN EN ISO 4762 Grade 10.9
M16 and upwards with washers: DIN EN ISO 7416

Dimension X is specified by the customer and determines the bolt length

When ordering please state: (Type x Ød x desired model) Dimension X for model C,
e.g. SDGH 50 - 72 x 50 x C X=10 mm

Shrink Disc Type SDGH – Series 71 | 72

Type	d mm	d _w mm	M _t kNm	P _{ax} kN	M _a Nm	Locking bolts*	D mm	l/2 mm	h mm	H ₁ mm	A mm	d ₁ mm	e mm	f mm	kg
SDGH 62 - 72		48	1.0	42	12	9 x M6	110	14	12.5	23	86	65	5	2.5	0.7
		50	1.1	46											
		52	1.3	49											
SDGH 68 - 72		50	1.0	39	12	9 x M6	115	14	12.5	23	86	71	5	2.5	0.7
		55	1.3	47											
		60	1.6	55											
SDGH 80 - 72		60	1.9	64	29	7 x M8	138	17	13	27	100	83.5	5	4	1.3
		75	2.4	73											
		70	2.9	82											
SDGH 90 - 72		65	2.9	89	29	10 x M8	155	20	16.5	31	114	96	6	5	1.9
		85	3.5	100											
		75	4.2	111											
SDGH 100 - 72		70	3.6	104	29	12 x M8	168	24.3	19	32	124	104	2	5	2.4
		95	4.3	116											
		80	5.1	128											
SDGH 110 - 72		80	5.2	130	58	9 x M10	185	24	21.5	37	136	115	7	5	3.1
		105	6.1	144											
		90	7.1	157											
SDGH 125 - 72		90	7.5	166	58	12 x M10	215	26	23	39	160	134	7	5	4.6
		120	8.5	180											
		130	9.7	194											
SDGH 140 - 71		95	9.6	203	100	10 x M12	230	28	25	43	176	146	8	5	6
		135	12.3	234											
		110	13.8	250											
SDGH 155 - 71		110	14.0	255	100	12 x M12	263	30	26	45	192	165	8	5	8
		150	15.6	271											
		160	17.2	287											
SDGH 165 - 71		120	20	334	240	8 x M16	290	33	29	54	210	174	7	5	11
		170	22	353											
		130	24	373											
SDGH 175 - 71		130	22	348	240	8 x M16	300	33	29	53	220	185	6	5	11
		180	24	366											
		140	27	385											
SDGH 185 - 71		140	31	442	240	10 x M16	320	40	36	63	236	195	9	5	16
		190	33	464											
		150	36	468											
SDGH 200 - 71		150	41	544	240	12 x M16	340	40	37	63	246	206	9	5	19
		195	44	568											
		160	47	592											
SDGH 220 - 71		160	51	638	240	15 x M16	370	52	45	77	276	230	11	8	27
		165	55	666											
		170	59	694											
SDGH 240 - 71		170	62	737	470	12 x M20	405	54	49	81	295	248	11	8	34
		180	71	795											
		190	81	855											
SDGH 260 - 71		190	86	912	470	12 x M20	430	59	53	83.5	321	268	9	8	41
		200	98	978											
		210	109	1045											

*Locking bolts: standard DIN EN ISO 4014/4017 Grade 10.9, alternative DIN EN ISO 4762 Grade 10.9
M16 and upwards with washers: DIN EN ISO 7416

When ordering please state: (Type x Ød x desired model) Dimension X for desired model C,
e.g. SDGH 260 - 71 x 260 x C X=80 mm

Shrink Disc Type SDGH – Series 71 | 72

Type	d mm	d _w mm	M _t kNm	P _{ax} kN	M _a Nm	Locking bolts*	D mm	l/2 mm	h mm	H ₁ mm	A mm	d ₁ mm	e mm	f mm	kg	
SDGH 280 - 71	280	210	113	1083	470	15 x M20	460	67	58	95	346	288	12	10	52	
		220	126	1153												
		230	140	1224												
SDGH 300 - 71	300	220	123	1124	470	16 x M20	485	71	60	96.5	364	308	10	10	60	
		230	137	1194												
		240	151	1264												
SDGH 320 - 71	320	240	157	1315	470	18 x M20	520	71	60	96.5	386	328	10	10	70	
		250	173	1389												
		260	190	1464												
SDGH 340 - 71	340	250	219	1755	470	24 x M20	570	77	69	102.5	420	348	10	10	94	
		260	239	1845												
		270	261	1936												
SDGH 360 - 71	360	270	242	1796	470	24 x M20	590	80	73	107	432	367	11	10	102	
		350	280	1882												
		290	285	1969												
SDGH 390 - 71	390	290	347	2399	820	20 x M24	650	85	76	113	468	397	9	13	134	
		380	300	375												2502
		310	404	2606												
SDGH 420 - 71	420	320	381	2383	820	20 x M24	670	95	82	123	504	428	9	13	151	
		330	409	2479												
		340	438	2576												
SDGH 440 - 71	440	340	463	2727	820	24 x M24	740	99	86	128	527	448	10	13	204	
		350	495	2829												
		360	527	2932												
SDGH 460 - 71	460	360	542	3014	820	24 x M24	760	99	86	127	547	468	9	13	220	
		370	576	3118												
		380	612	3223												
SDGH 480 - 71	480	380	628	3308	820	28 x M24	785	109	97	143	570	490	15	15	260	
		390	666	3417												
		400	705	3526												
SDGH 500 - 71	500	400	760	3801	1100	24 x M27	850	109	96	145	590	508	14	15	301	
		410	803	3919												
		420	847	4037												
SDGH 530 - 71	530	430	1043	4851	1100	30 x M27	910	122	108	156	620	538	12	15	390	
		440	1097	4989												
		450	1153	5126												
SDGH 560 - 71	560	450	1083	4815	1100	30 x M27	940	122	108	156	650	568	12	15	406	
		460	1137	4945												
		470	1192	5075												

Further sizes on request, subject to technical changes.

*Locking bolts: standard DIN EN ISO 4014/4017 Grade 10.9, alternative DIN EN ISO 4762 Grade 10.9
M16 and upwards with washers: DIN EN ISO 7416

When ordering please state: (Type x Ød x desired model) Dimension X for model C,
e.g. SDGH 560 - 71 x 560 x C X=115 mm

You have not found what you are looking for in our comprehensive range of standard-products?
We will be happy to promptly prepare any form of custom-made product and development innovation
even using special materials such as 1.3974. Please feel free to contact us.

Shrink Disc Type SDG and SDGH Special Solutions

Complete Solution ZSDG

Example: Complete gearwheel including locking elements

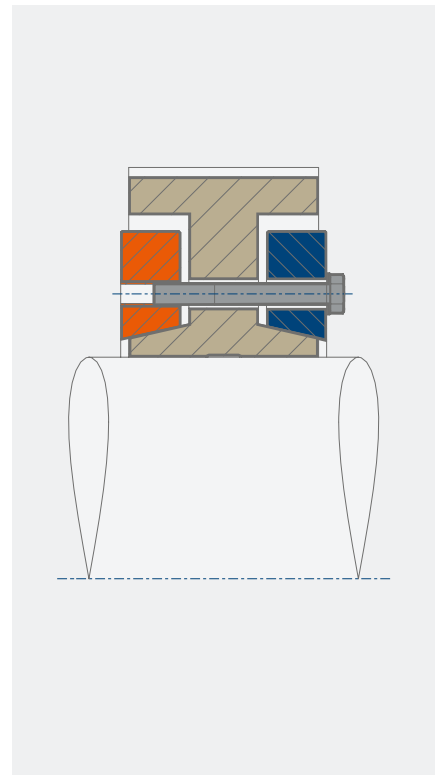
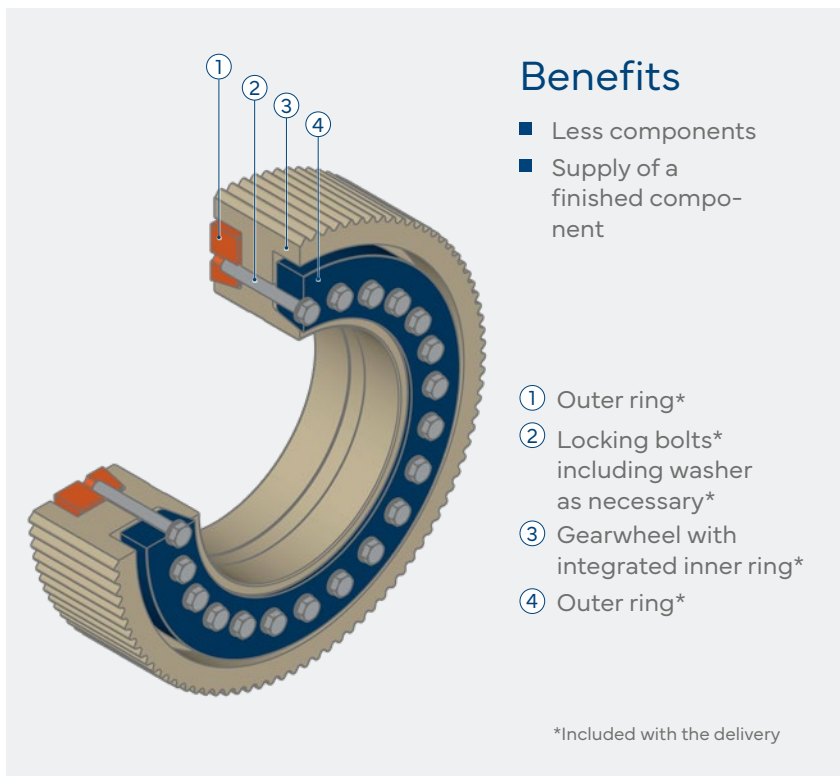

STÜWE[®]

External Locking Unit

Type AS



External Locking Unit Type AS

General Information

Application Description

Type AS external locking units are used for the fixing of removable attachments such as brake discs, sheaves or pulleys to all forms of shaft. This type of fixture is characterized in particular by its easy and free positioning, non-destructive installation and removal and high transmissible loads. Differentiation is made in the standard delivery programme between the following four models so that an optimum variance exists for the achievement of your ideal connection.

Areas of Use



Driveline technology



Steel- & rolling mill equipment



Crushing equipment



Conveying equipment



Agitation & mixing equipment

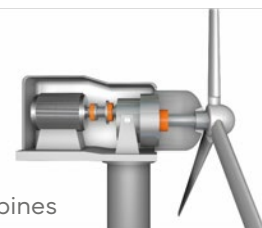

Wind turbines



External Locking Unit

Type AS – Series

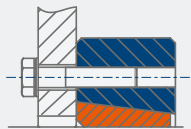

Model A:
Thread in the outer ring

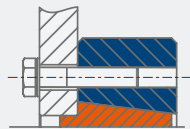

Model AB:
Thread in the outer ring
and centring device

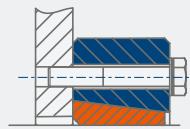

Model C:
Thread in the
attachment

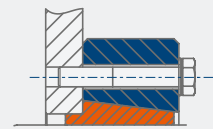

Model BC:
Thread in the attachment
and centring device

Description	Shaft diameter	Transmissible torque	Features
12	9 - 100 mm	0.02 - 15.8 kNm	Average torques; without bending moment
22	11 - 440 mm	0.05 - 426 kNm	High torques + bending moment
23	40 - 440 mm	3.3 - 562 kNm	Extremely high torques + bending moment

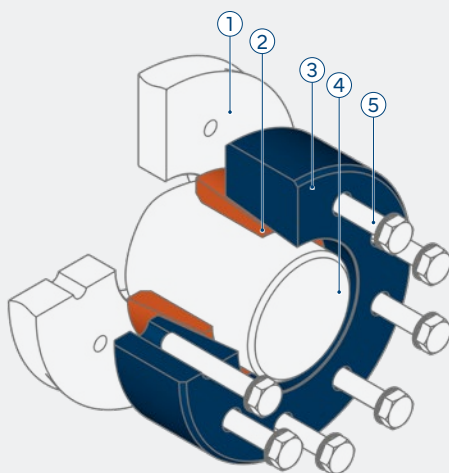

- ① Attachment (for example, a sheave)
- ② Inner ring*
- ③ Outer ring*
- ④ Shaft
- ⑤ Locking bolts
including washer as necessary

*Included with the delivery

All types may be protected against environmental influences by zinc and nickel coating or by a paint which has an appropriate corrosion protection class. We are able to achieve both desired colours which conform with the RAL colour range and products with lubricants in accordance with NSF H1. More detailed information on this may be found in this catalogue on page 151.

External Locking Unit Type AS – Series 12

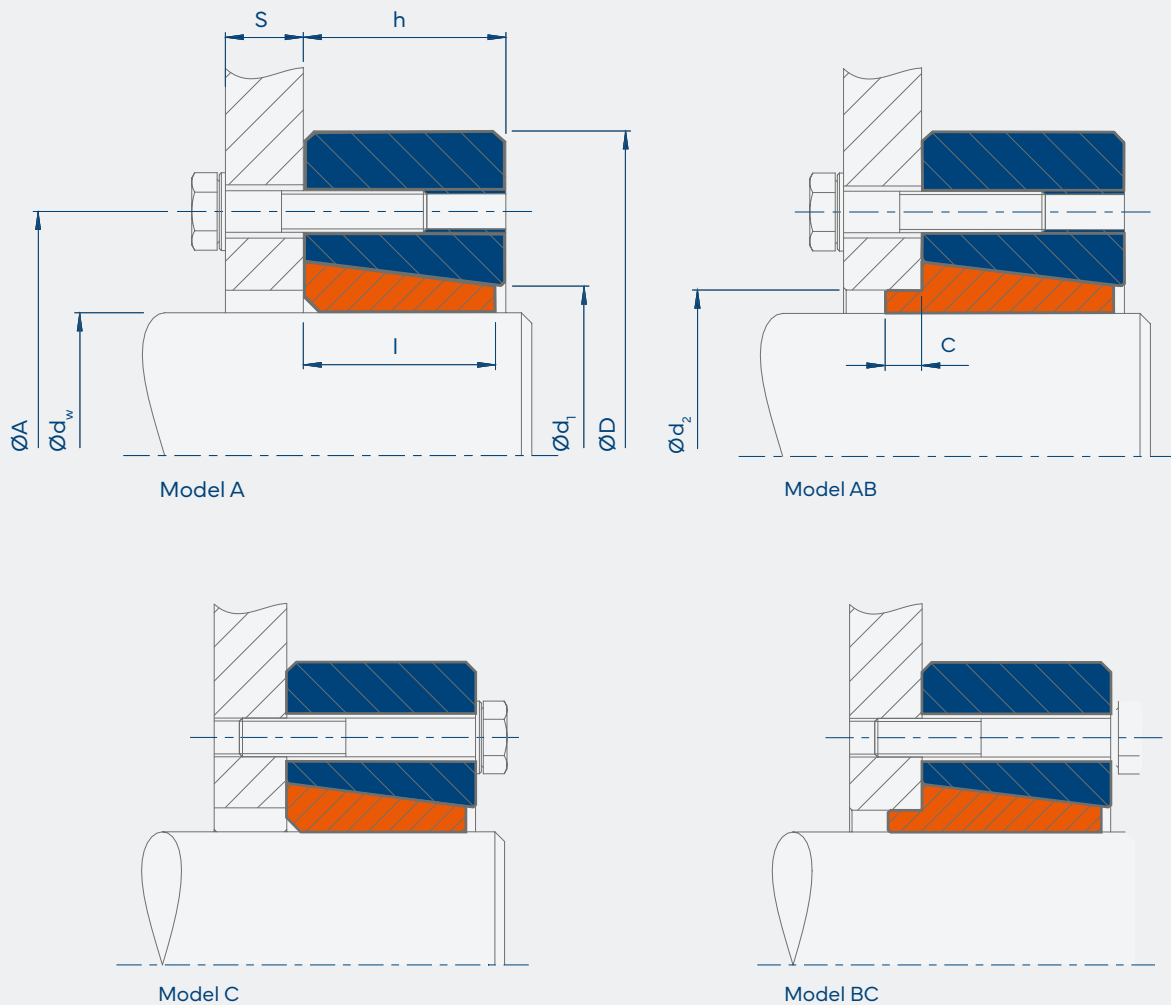

Code

- M_t Maximum transmissible torque of an external locking unit for $P_{ax} = 0$
- M_a Required tightening torque of the locking bolts (see also "Installation and Removal Instructions")

Information on fits:

$\text{Ø}d_w$: h9
 $\text{Ø}d_2$: H7/g6

all models:
 $S > 1.4 \times \text{Bolts-Ø}$

Roughness of all mating surfaces:
 $Ra < 3.2 \mu\text{m}$

For the transmission of torque only. For the transmission of both torque and bending moments select series 22 or 23.

External Locking Unit Type AS – Series 12

Type	d _w * mm	M _t kNm	B** Grade 10.9	M _a Nm	A mm	D mm	I mm	h mm	C mm	d ₁ mm	d ₂ mm	kg
AS 10 - 12	11	0.02	3 x M6 x 18	12	25	39	9	10	1.5	13	12	0.1
	10	0.02										
	9	0.02										
AS 12 - 12	13	0.05	3 x M6 x 20	12	28	44	12	13	1.5	16	14	0.1
	12	0.05										
	11	0.05										
AS 15 - 12	16	0.13	3 x M8 x 25	29	36	52	14	15	2	21	18	0.2
	15	0.13										
	14	0.13										
AS 20 - 12	20	0.20	3 x M8 x 30	29	42	60	16	17	2	25	22	0.3
	18	0.20										
	16	0.20										
AS 25 - 12	25	0.34	5 x M8 x 30	29	48	66	18	19	2	32	27	0.4
	22	0.34										
	20	0.34										
AS 30 - 12	30	0.55	6 x M8 x 35	29	56	76	20	21	2	38	32	0.6
	28	0.55										
	25	0.55										
AS 40 - 12	40	1.06	6 x M10 x 35	58	70	96	24	25	3	47	43	1.2
	35	1.06										
	30	1.06										
AS 50 - 12	50	2.20	7 x M12 x 45	100	84	112	29	30	3	58	53	2.0
	45	1.80										
	40	1.00										
AS 60 - 12	60	3.23	9 x M12 x 50	100	94	120	32	34	3	66	63	2.3
	55	3.23										
	50	2.30										
AS 70 - 12	70	5.80	8 x M16 x 60	240	112	148	38	40	4	79	74	4.2
	65	5.80										
	60	4.50										
AS 80 - 12	80	8.64	9 x M16 x 65	240	130	170	42	44	4	94	84	6.1
	75	8.64										
	70	6.90										
AS 90 - 12	90	12.00	12 x M16 x 70	240	144	185	48	50	4	104	94	8.0
	85	12.00										
	80	10.70										
AS 100 - 12	100	15.80	14 x M16 x 75	240	156	197	52	54	4	113	104	9.5
	95	15.80										
	90	15.80										

Further sizes on request, subject to technical changes.

*Hole diameter can be freely chosen within given limitations.

**Locking bolts: standard DIN EN ISO 4014/4017/4014: Length for model C and BC, alternative DIN EN ISO 4762 M16 and upwards with washers: DIN EN ISO 7416

When ordering please state: (Type x Ød_w x desired model) flange width S for model A and AB
e.g. AS 70 - 12 x 65 x A S=8 mm

External Locking Unit Type AS – Series 22

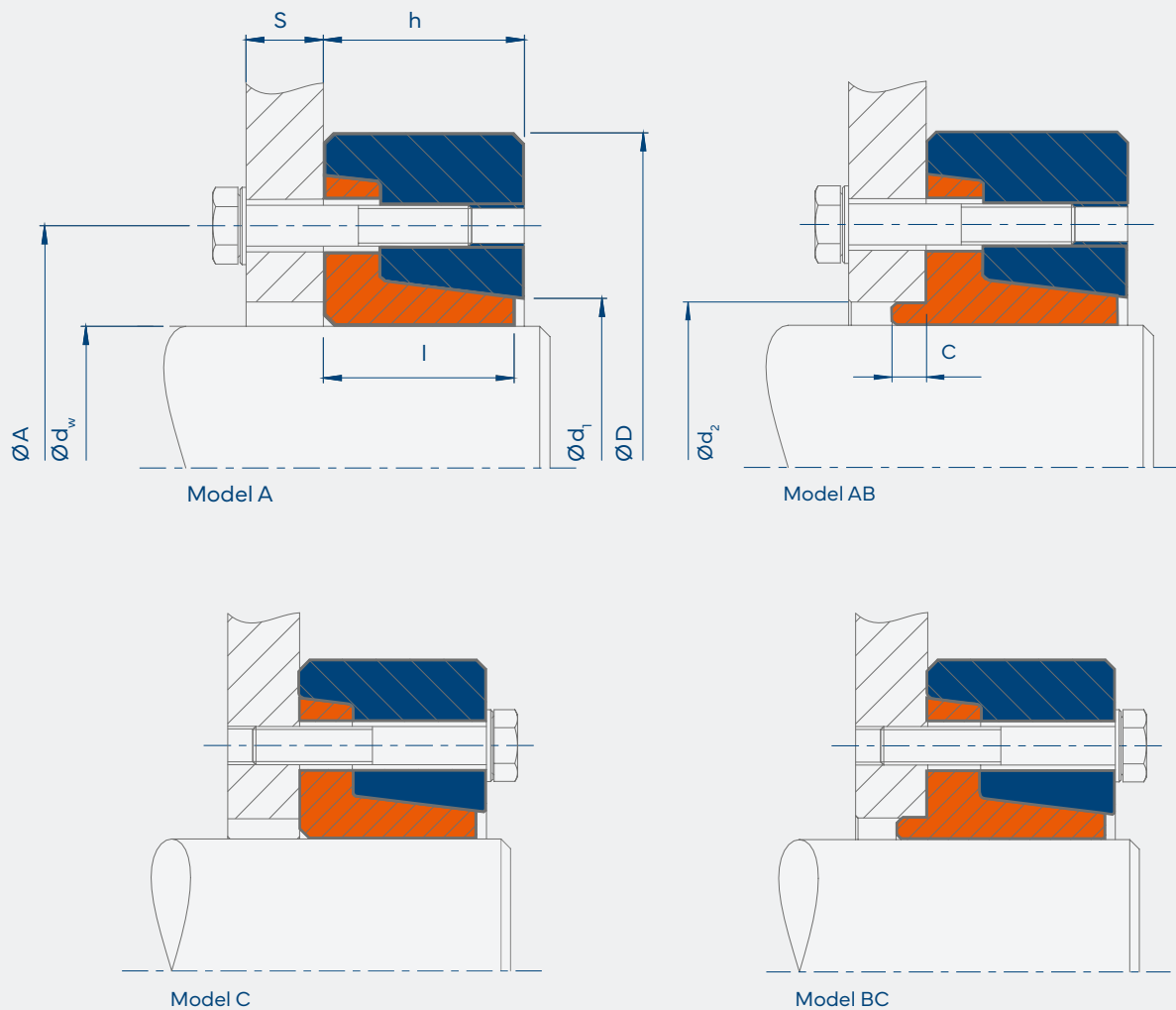

Code

- M_t Maximum transmissible torque of an external locking unit for $P_{ax} = 0$
- M_a Required tightening torque of the locking bolts (see also "Installation and Removal Instructions")

Information on fits:

$\text{Ø}d_w$: h9
 $\text{Ø}d_2$: H7/g6

all models:
 $S > 1.4 \times \text{Bolts-Ø}$

Roughness of all mating surfaces:
 $Ra < 3.2 \mu\text{m}$

External Locking Unit Type AS – Series 22

Type	d _w * mm	M _t kNm	B** Grade 10.9	M _a Nm	A mm	D mm	l mm	h mm	C mm	d ₁ mm	d ₂ mm	kg
AS 12 - 22	12	0.05	3 x M6 x 20	12	24	35	10	7	1.5	13	14	0.1
	11	0.05										
AS 14 - 22	14	0.07	3 x M6 x 20	12	26	38	10	7.3	1.5	15	16	0.1
	13	0.07										
AS 16 - 22	16	0.08	3 x M6 x 25	12	28	41	13.5	9	2	17	18	0.1
	15	0.08										
AS 18 - 22	18	0.13	4 x M6 x 25	12	30	44	13.5	9	2	19	20	0.1
	17	0.13										
AS 20 - 22	20	0.14	4 x M6 x 25	12	32	47	13.5	9	2	21	22	0.2
	19	0.14										
AS- 25 - 22	25	0.20	5 x M6 x 30	12	36	50	17	17	2	26	27	0.2
	24	0.20										
	22	0.20										
AS 30 - 22	30	0.30	6 x M6 x 30	12	44	60	18	19	3	32	32	0.3
	28	0.30										
	26	0.30										
AS 35 - 22	36	0.50	5 x M8 x 35	29	52	72	20	21	3	38	38	0.5
	35	0.50										
	32	0.45										
AS 40 - 22	44	0.75	6 x M8 x 35	29	61	80	22	23	3	47	46	0.7
	40	0.75										
	38	0.72										
AS 50 - 22	50	1.3	8 x M8 x 40	29	68	90	24	25	3	53	53	0.9
	45	1.3										
	42	1.0										
AS 55 - 22	55	1.6	8 x M8 x 40	29	72	100	26	27	3	58	58	1.2
	52	1.6										
	45	1.6										
AS 60 - 22	60	2.0	9 x M8 x 40	29	80	110	26	27	3	66	63	1.4
	55	2.0										
	50	2.0										
AS 70 - 22	70	2.1	9 x M8 x 40	29	86	115	26	27	4	72	74	1.5
	65	2.1										
	60	2.1										
AS 80 - 22	80	4.0	10 x M10 x 45	58	100	141	28	29	4	84	84	2.5
	75	4.0										
	70	4.0										
AS 90 - 22	90	5.7	12 x M10 x 50	58	114	155	34	35	4	94	94	3.6
	85	5.7										
	80	5.7										
AS 100 - 22	100	8.4	12 x M12 x 60	100	124	170	39	40	4	104	104	4.6
	95	8.4										
	90	8.4										
AS 110 - 22	110	9.2	12 x M12 x 70	100	136	185	45	46	5	114	116	6.2
	105	9.2										
	100	9.2										

*Hole diameter can be freely chosen within given limitations. **Locking bolts: standard
DIN EN ISO 4014/4017/4014: Length for model C and BC, alternative DIN EN ISO 4762 | M16 and upwards with
washers: DIN EN ISO 7416 **When ordering please state:** (Type x Ød_w x desired model) flange width S for model A
and AB, e.g. AS 40 - 22 x 44 x A S=8 mm

External Locking Unit Type AS – Series 22

Type	d _w * mm	M _t kNm	B** Grade 10.9	M _a Nm	A mm	D mm	l mm	h mm	C mm	d ₁ mm	d ₂ mm	kg
AS 125 - 22	125	21	12 x M16 x 75	240	160	215	47	49	5	133	126	8.8
	120	21										
	115	21										
AS 140 - 22	140	26	14 x M16 x 80	240	172	230	52	53	5	145	146	11
	135	26										
	130	26										
AS 155 - 22	160	31	15 x M16 x 80	240	192	263	54	55	5	162	166	15
	155	31										
	150	31										
AS 170 - 22	170	36	16 x M16 x 90	240	204	290	61	62	5	175	176	21
	165	36										
	160	36										
AS 180 - 22	180	43	18 x M16 x 90	240	218	300	61	62	5	185	186	22
	175	43										
	170	43										
AS 190 - 22	190	60	15 x M20 x 110	470	232	320	77	78	5	195	196	31
	185	60										
	180	60										
AS 200 - 22	200	67	16 x M20 x 110	470	246	340	75	78	5	209	206	35
	195	67										
	190	67										
AS 220 - 22	220	93	14 x M24 x 130	820	270	370	95	96	5	230	226	53
	210	93										
	200	93										
AS 240 - 22	240	117	16 x M24 x 140	820	296	405	98	100	5	248	246	64
	230	117										
	220	117										
AS 260 - 22	260	126	16 x M24 x 150	820	318	430	106	106	5	266	266	80
	250	126										
	240	126										
AS 280 - 22	280	151	18 x M24 x 160	820	340	460	118	118	5	288	286	95
	270	151										
	260	151										
AS 300 - 22	300	178	20 x M24 x 170	820	360	485	125	126	5	309	306	110
	290	178										
	280	178										
AS 320 - 22	320	248	20 x M27 x 170	1210	380	520	125	126	5	328	330	134
	300	248										
	280	248										
AS 340 - 22	340	275	21 x M27 x 180	1210	402	570	134	136	5	351	350	180
	320	275										
	300	275										
AS 360 - 22	360	290	21 x M27 x 180	1210	424	590	142	144	8	367	370	200
	340	290										
	320	290										
AS 390 - 22	390	363	20 x M30 x 190	1640	458	630	146	148	8	398	400	222
	370	363										
	350	363										
AS 420 - 22	420	407	21 x M30 x 210	1640	490	650	166	168	8	424	430	263
	400	407										
	380	407										
AS 440 - 22	440	426	21 x M30 x 220	1640	512	670	174	176	8	448	450	309
	420	426										
	400	426										

Further sizes on request, subject to technical changes. *Hole diameter can be freely chosen within given limitations. **Locking bolts: standard DIN EN ISO 4017/4014: Length for model C and BC, alternative DIN EN ISO 4762 M16 and upwards with washers: DIN EN ISO 7416 | **When ordering please state:** (Type x Ød_w x desired model) flange width S for model A and AB e.g. AS 300 - 22 x 290 x A S=50 mm

External Locking Unit Type AS – Series 23

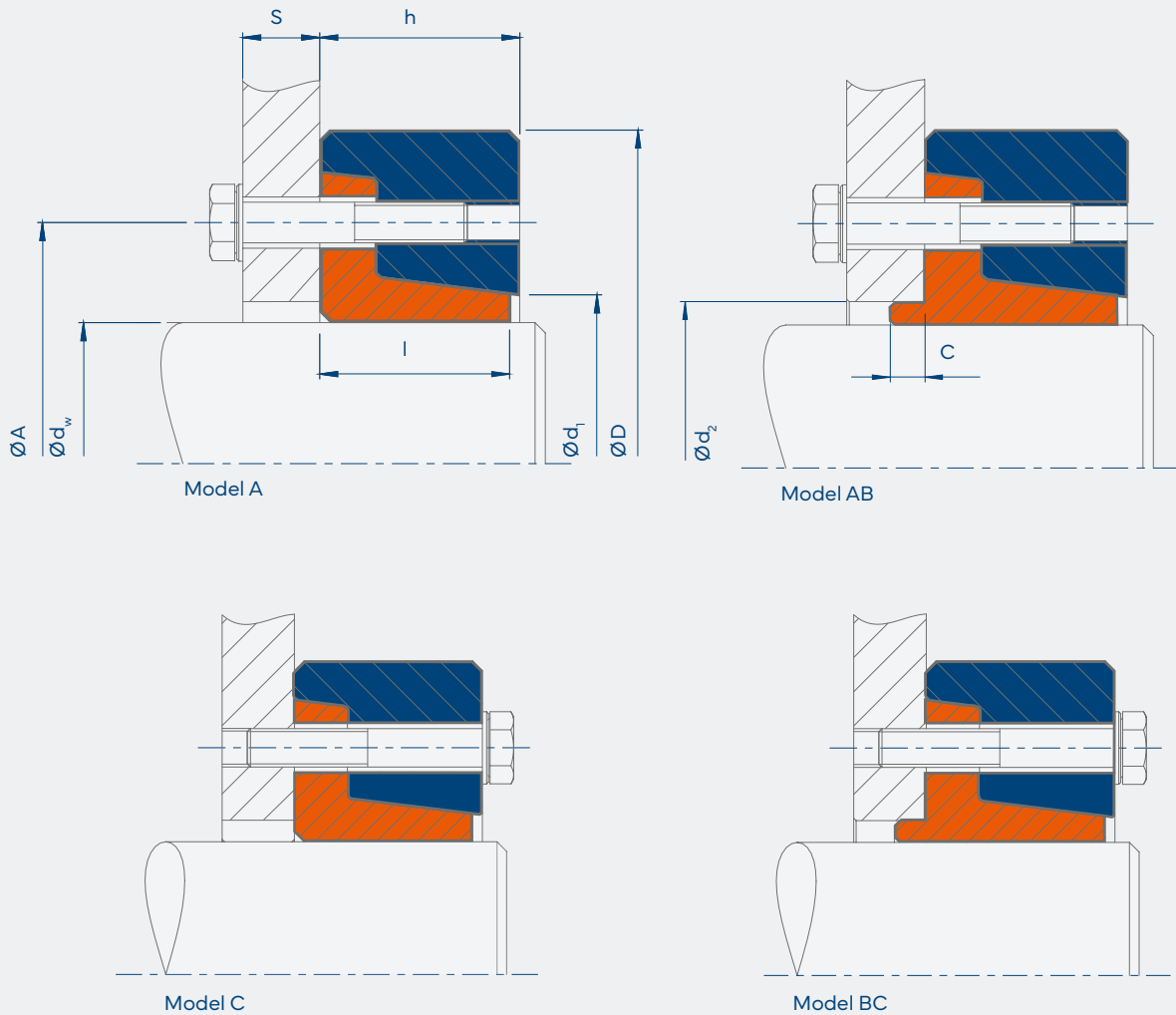

Code

- M_t Maximum transmissible torque of an external locking unit for $P_{ax} = 0$
- M_a Required tightening torque of the locking bolts (see also "Installation and Removal Instructions")

Information on fits:

$\text{Ø}d_w$: h9
 $\text{Ø}d_2$: H7/g6

all models:
 $S > 1.4 \times \text{Bolts-Ø}$

Roughness of all mating surfaces:
 $Ra < 3.2 \mu\text{m}$

External Locking Unit Type AS – Series 23

Type	d _w * mm	M _t kNm	B** Grade 10.9	M _a Nm	A mm	D mm	I mm	h mm	C mm	d ₁ mm	d ₂ mm	kg
AS 50 - 23	50	3.3	7 x M12 x 45	100	84	115	29	30	3	58	53	2.0
	45	2.2										
	40	1.4										
AS 60 - 23	60	4.7	9 x M12 x 50	100	94	120	32	34	3	66	63	2.2
	55	3.5										
	50	2.3										
AS 70 - 23	70	9.4	8 x M16 x 60	240	112	148	38	40	4	79	74	3.9
	65	7.6										
	60	5.8										
AS 80 - 23	80	12	9 x M16 x 65	240	130	167	42	44	4	94	84	5.4
	75	10										
	70	8										
AS 90 - 23	90	18	12 x M16 x 70	240	144	185	48	50	4	104	94	7.4
	85	15										
	80	12										
AS 100 - 23	100	23	14 x M16 x 75	240	156	197	52	54	4	113	104	8.7
	95	19										
	90	16										
AS 110 - 23	110	27	10 x M20 x 90	470	166	215	56	58	5	124	116	11.0
	105	26										
	100	22										
AS 120 - 23	120	43	14 x M20 x 90	470	186	230	62	65	5	134	126	13.6
	115	38										
	110	33										
AS 140 - 23	140	56	16 x M20 x 100	470	216	290	73	76	5	160	146	29.0
	130	50										
	120	39										
AS 160 - 23	160	77	14 x M24 x 110	820	234	320	80	80	5	185	166	36.1
	150	77										
	140	64										
AS 180 - 23	180	104	16 x M24 x 130	820	276	340	91	94	5	205	186	45.3
	170	101										
	160	85										
AS 200 - 23	200	144	16 x M27 x 140	1210	290	370	95	96	5	226	206	53.7
	190	133										
	180	114										
AS 220 - 23	220	178	18 x M27 x 140	1210	320	405	96	96	5	246	226	64.3
	210	178										
	200	159										
AS 240 - 23	240	211	20 x M27 x 150	1210	340	430	109	110	5	267	246	81.0
	230	211										
	220	211										
AS 260 - 23	260	232	21 x M27 x 160	1210	356	460	118	118	5	289	286	109.4
	250	232										
	240	232										
AS 280 - 23	280	234	21 x M27 x 180	1210	360	485	124	125	5	304	306	116
	270	234										
	260	234										

*Hole diameter can be freely chosen within given limitations.

**Locking bolts: standard DIN EN ISO 4017/4014: Length for model C and BC, alternative DIN EN ISO 4762
M16 and upwards with washers: DIN EN ISO 7416

When ordering please state: (Type x Ød_w x desired model) flange width S for model A and AB
e.g. AS 180 - 23 x 175 x A S=50

External Locking Unit Type AS – Series 23

Type	d _w * mm	M _t kNm	B** Grade 10.9	M _a Nm	A mm	D mm	l mm	h mm	C mm	d ₁ mm	d ₂ mm	kg
AS 300 - 23	300	247	21 x M27 x 180	1210	380	520	128	126	5	315	330	141
	290	247										
	280	247										
AS 320 - 23	320	299	24 x M27 x 180	1210	402	550	134	136	5	336	350	161
	310	299										
	300	299										
AS 340 - 23	340	315	24 x M27 x 180	1210	424	570	140	142	8	355	370	177
	330	315										
	320	315										
AS 360 - 23	360	410	24 x M30 x 190	1640	454	610	144	147	8	383	400	210
	350	410										
	340	410										
AS 390 - 23	390	439	24 x M30 x 200	1640	486	630	164	167	8	428	430	250
	380	439										
	360	439										
AS 420 - 23	420	457	24 x M30 x 220	1640	506	670	172	175	10	448	450	292
	410	457										
	390	457										
AS 440 - 23	440	562	28 x M30 x 220	1640	534	700	172	175	10	468	470	318
	420	562										
	400	562										

Further sizes on request, subject to technical changes.

*Hole diameter can be freely chosen within given limitations.

**Locking bolts: standard DIN EN ISO 4017/4014: Length for model C and BC, alternative DIN EN ISO 4762 M16 and upwards with washers: DIN EN ISO 7416

When ordering please state: (Type x Ød_w x desired model) flange width S for model A and AB
e.g. AS 320 - 23 x 320 x A S=90 mm

You have not found what you are looking for in our comprehensive range of standard-products?
We will be happy to promptly prepare any form of custom-made product and development innovation
even using special materials such as 1.3974. Please feel free to contact us.

External Locking Unit Type AS

Special Solutions

Individual solution DAS

double AS for disc-shaped attachments with very heavy loads

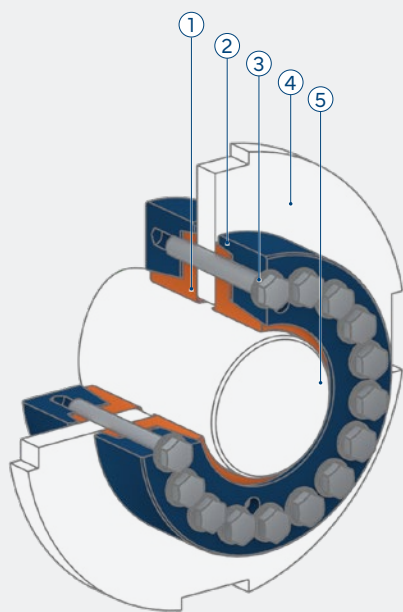

Benefits

- Higher transmissible loads
- More accurate positioning of the disc

- ① Inner ring*
- ② Outer ring*
- ③ Locking bolts* including washer as necessary*
- ④ Disc-shaped attachment (e.g. a brake disc)
- ⑤ Shaft

*Included with the delivery

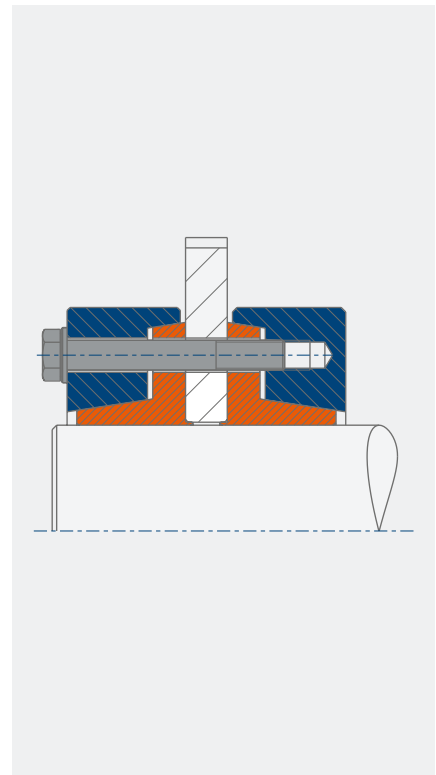

Clamping Element GAS

divided AS for the transmission of axial loads

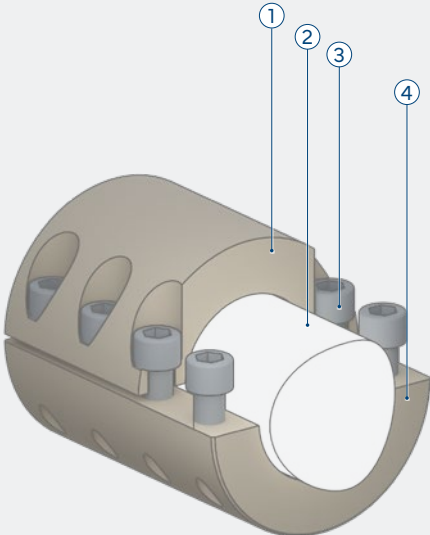

① Upper section*
② Shaft
③ Locking bolts*
④ Lower section*

- Radial installation and removal
- Space-saving installation
- Unattached to other components

*Included with the delivery

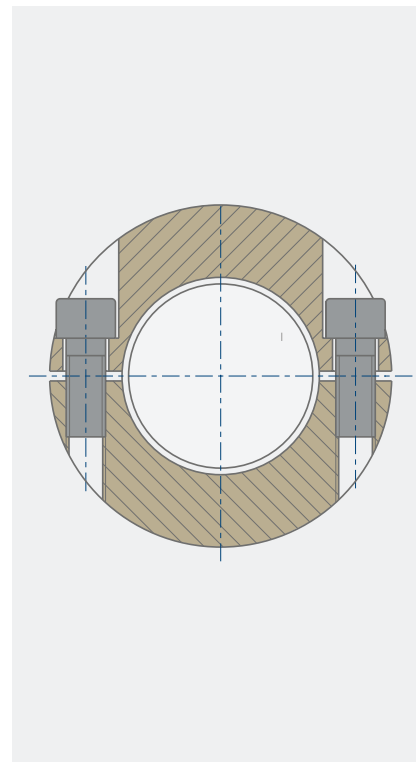

AS as an Oscillating Weight

clamped swinging element as an energy store

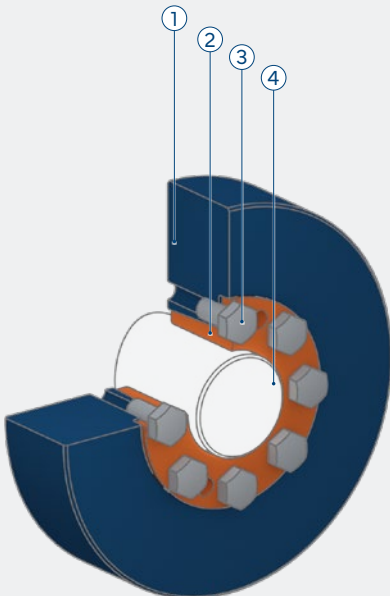

① Outer ring*
② Inner ring*
③ Locking bolts* including washer as necessary*
④ Shaft

- Design based on mass inertia
- Individual customizing

*Included with the delivery

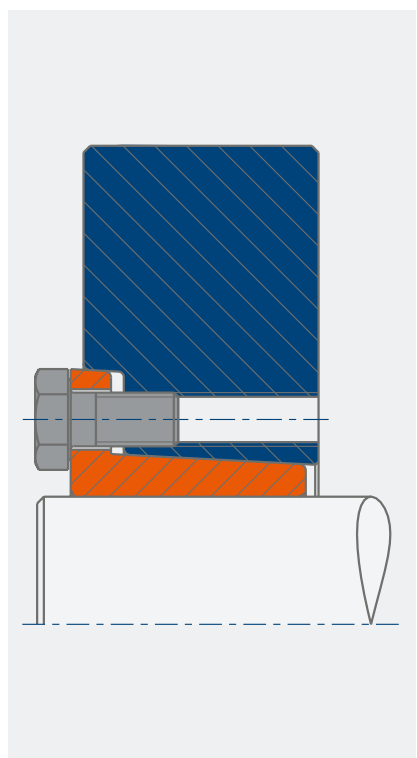

Adapter Flange AD

Adaption of clamping and bolt connections

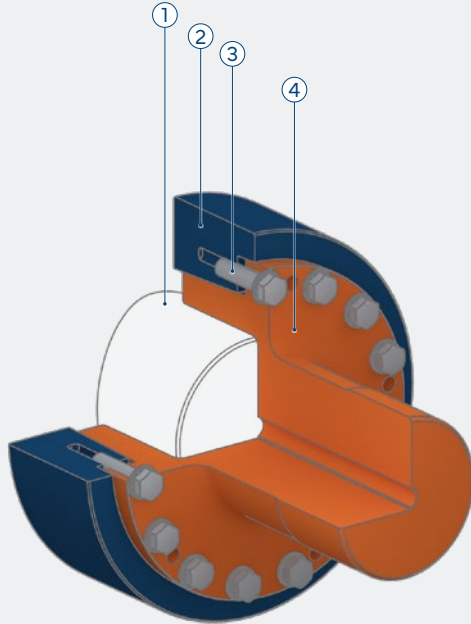

Benefits

- Less components
- Even shafts of unequal size can be connected
- Bridging of wide spaces
- Clamping element integrated

- ① Shaft
- ② Outer ring*
- ③ Locking bolts* including washer as necessary*
- ④ Inner ring*

*Included with the delivery

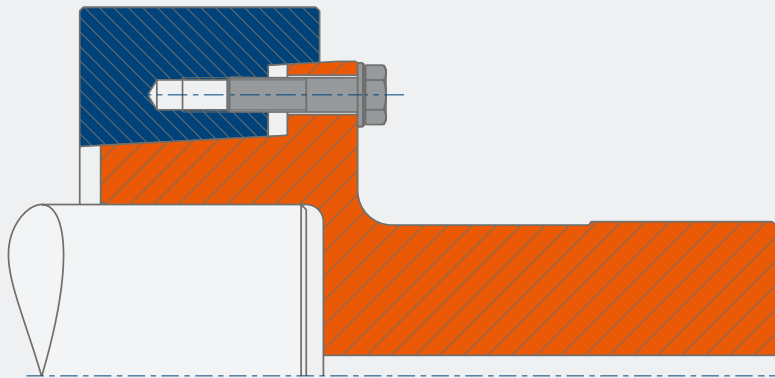

STÜWE[®]

Shaft Coupling

Type WK and WKL



Shaft Coupling Type WK and WKL

General Information

Application Description

The shaft couplings WK and WKL are suited in all cases where a secure, fixed connection between two free shaft ends with little effort is demanded. The couplings are provided for shafts with identical or differing shaft diameters and fitting tolerances. Type WKL shaft couplings are used for larger axial distances between the shaft ends. Type WK shaft couplings are suitable for smaller axial distances.

Areas of Use



Driveline technology



Steel- & rolling mill equipment

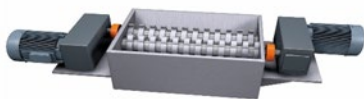

Crushing equipment

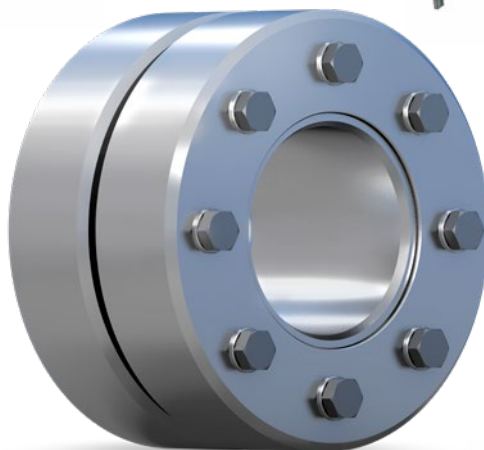

Conveying equipment



Agitation & mixing equipment

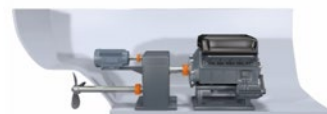

Shipbuilding

Shaft Coupling

Type WK and WKL – Series

Description	Shaft diameter	Transmissible torque	Features
WK 12	9 - 750 mm	0.04 - 7116 kNm	The maximum distance of the shaft ends is 0.1 x L.
WKL 12	9 - 750 mm	0.04 - 7116 kNm	Long version

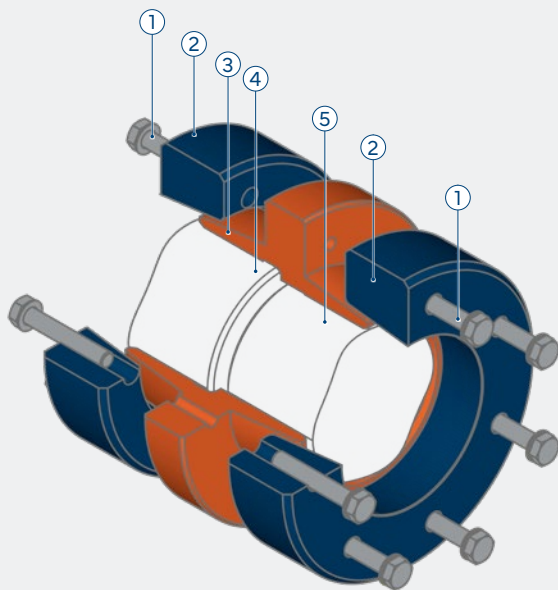

- ① Locking bolt*
including washer as necessary*
- ② Outer ring*
- ③ Inner ring*
- ④ Shaft 1
- ⑤ Shaft 2

*Included with the delivery

All types may be protected against environmental influences by zinc and nickel coating or by a paint which has an appropriate corrosion protection class. We are able to achieve both desired colours which conform with the RAL colour range and products with lubricants in accordance with NSF H1. More detailed information on this may be found in this catalogue on page 151.

Shaft Coupling Type WK Series 12

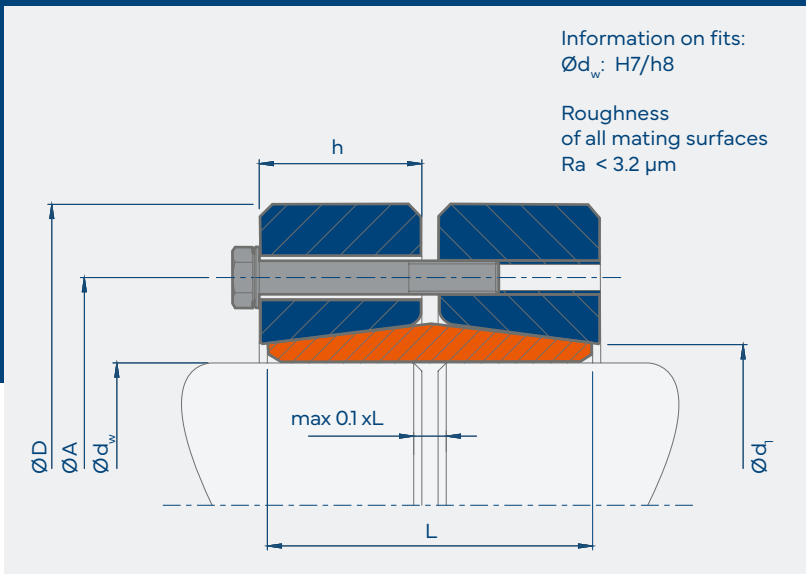

Code

- M_t Maximum transmissible torque of a shrink disc for $P_{ax} = 0$
- P_{ax} Maximum transmissible axial load of a shrink disc for $M_t = 0$
- M_a Required tightening torque of the locking bolts (see also "Installation and Removal Instructions")

Shaft Coupling Type WK – Series 12

Type	d_w^* mm	M_t kNm	P_{ax} kN	M_a Nm	B**	D mm	L mm	h mm	A mm	d_1 mm	kg
WK 10 - 12	9	0.04	8	12	M6	39	20	10	25	13	0.2
	10	0.04	9								
	11	0.05	10								
WK 12 - 12	12	0.07	11	12	M6	44	26	13	28	16	0.3
	13	0.08	12								
	14	0.09	13								
WK 15 - 12	15	0.16	21	29	M8	52	30	15	36	21	0.5
	17	0.20	24								
	19	0.26	27								
WK 20 - 12	20	0.29	29	29	M8	60	34	17	42	25	0.7
	22	0.35	32								
	24	0.41	35								
WK 25 - 12	25	0.49	40	29	M8	66	38	19	48	32	0.9
	27	0.58	43								
	29	0.66	46								
WK 30 - 12	30	0.77	51	29	M8	76	42	21	56	38	1.3
	32	0.87	55								
	35	1.05	60								
WK 40 - 12	36	1.3	70	58	M10	96	50	25	70	47	2.5
	40	1.8	92								
	43	2.3	109								
WK 50 - 12	44	2.3	102	100	M12	112	60	30	84	58	4.2
	50	3.4	137								
	54	4.3	161								
WK 60 - 12	55	4.1	150	100	M12	120	68	34	94	66	4.8
	60	5.5	184								
	62	6.1	197								

*Hole diameter can be freely chosen within given limitations.

**Locking bolts: DIN EN ISO 4017/4014 grade 10.9 as standard, alternatively DIN EN ISO 4762 grade 10.9 M16 and upwards with washers: DIN EN ISO 7416

When ordering please state: (Type x $\varnothing d_w$), e.g. WK 40 - 12 x 43

Shaft Coupling Type WK – Series 12

Type	d _w [*] mm	M _t kNm	P _{ax} kN	M _a Nm	B ^{**}	D mm	L mm	h mm	A mm	d ₁ mm	kg
WK 70 - 12	63	6.2	196	100	M12	148	80	40	112	79	9.1
	70	8.6	245								
	73	9.7	266								
WK 80 - 12	74	10	275	160	M14	170	94	44	130	94	13.4
	80	13	320								
	85	15	358								
WK 90 - 12	86	16	381	240	M16	185	104	50	144	104	17.5
	90	19	417								
	95	22	461								
WK 100 - 12	96	23	483	240	M16	197	114	54	156	113	20.9
	100	26	521								
	106	31	578								
WK 120 - 12	107	35	648	240	M16	230	138	65	174	133	34.6
	120	47	787								
	125	53	841								
WK 140 - 12	126	56	881	470	M20	290	160	76	216	160	67.5
	140	74	1052								
	150	88	1178								
WK 160 - 12	150	81	1081	470	M20	320	176	83	234	180	85
	160	96	1202								
	165	104	1264								
WK 180 - 12	165	114	1381	470	M20	340	200	94	260	205	107
	180	143	1594								
	185	154	1665								
WK 200 - 12	185	164	1778	470	M20	370	228	96	290	226	134
	200	201	2011								
	210	228	2169								
WK 220 - 12	210	231	2199	820	M24	405	250	118	320	246	184
	220	260	2362								
	230	291	2527								
WK 240 - 12	230	271	2353	820	M24	430	270	128	340	267	221
	240	302	2513								
	250	334	2675								
WK 260 - 12	240	322	2683	1210	M27	460	290	138	366	288	268
	250	357	2860								
	260	395	3039								
WK 280 - 12	260	424	3265	1210	M27	485	330	166	400	308	347
	270	467	3459								
	280	512	3656								
WK 300 - 12	280	530	3787	1210	M27	520	346	174	420	328	415
	290	579	3990								
	300	629	4195								
WK 320 - 12	300	662	4414	1640	M30	550	376	190	446	348	501
	310	718	4631								
	320	776	4849								
WK 340 - 12	320	806	5038	1640	M30	590	380	194	466	368	589
	330	869	5267								
	340	935	5499								
WK 360 - 12	340	967	5686	2210	M33	650	400	202	500	398	770
	350	1037	5924								
	360	1109	6163								

Further sizes on request, subject to technical changes.

*Hole diameter can be freely chosen within given limitations.

**Locking bolts: DIN EN ISO 4017/4014 grade 10.9 as standard, alternatively DIN EN ISO 4762 grade 10.9

M16 and upwards with washers: DIN EN ISO 7416

When ordering please state: (Type x Ød_w), e.g. WK 220 - 12 x 210

Shaft Coupling Type WK – Series 12

Type	d _w * mm	M _t kNm	P _{ax} kN	M _a Nm	B**	D mm	L mm	h mm	A mm	d ₁ mm	kg
WK 390 - 12	370	1195	6459	2210	M33	670	440	224	530	428	891
	380	1274	6706								
	390	1356	6954								
WK 420 - 12	400	1637	8187	2210	M33	740	470	238	560	448	1175
	410	1737	8471								
	420	1839	8758								
WK 460 - 12	430	1841	8561	2210	M33	780	500	246	590	498	1291
	450	2050	9112								
	460	2160	9390								
WK 500 - 12	470	2568	10929	2850	M36	860	560	276	656	540	1772
	480	2700	11249								
	500	2974	11895								
WK 550 - 12	510	3014	11820	2850	M36	960	600	296	710	600	2421
	530	3301	12456								
	550	3602	13097								
WK 600 - 12	560	3610	12893	2850	M36	1000	620	310	760	650	2614
	580	3921	13520								
	600	4245	14151								
WK 650 - 12	620	4555	14695	2850	M36	1080	640	320	824	700	3074
	630	4732	15023								
	650	5097	15684								
WK 700 - 12	660	5360	16243	2850	M36	1140	680	340	890	760	3608
	680	5751	16916								
	700	6158	17593								
WK 750 - 12	710	6256	17623	2850	M36	1280	720	360	950	814	5016
	730	6679	18298								
	750	7116	18977								

Further sizes on request, subject to technical changes.

*Hole diameter can be freely chosen within given limitations.

**Locking bolts: DIN EN ISO 4017/4014 grade 10.9 as standard, alternatively DIN EN ISO 4762 grade 10.9

M16 and upwards with washers: DIN EN ISO 7416

When ordering please state: (Type x Ød_w), e.g. WK 750 - 12 x 710

Shaft Coupling Type WKL Series 12

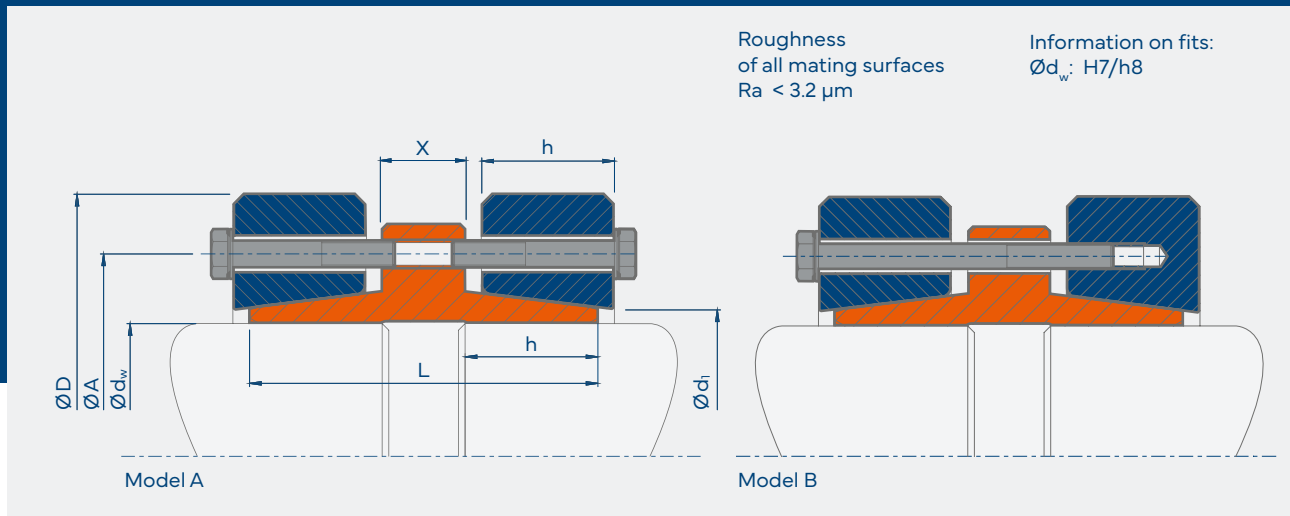

Code

- M_t Maximum transmissible torque of a shaft coupling for $P_{ax} = 0$
- P_{ax} Maximum transmissible axial load of a shaft coupling for $M_t = 0$
- M_a Maximum tightening torque of the locking bolts (see also "Installation and Removal Instructions")
- X L - 2 · h, the design of this length can be varied

Shaft Coupling Type WKL – Series 12

Type	d_w^* mm	M_t kNm	P_{ax} kN	M_a Nm	B**	D mm	L mm	h mm	A mm	d_1 mm	kg
WKL 10 - 12	9	0.04	8	12	M6	39	32	10	25	13	0.3
	10	0.04	9								
	11	0.05	10								
WKL 12 - 12	12	0.07	11	12	M6	44	38	13	28	16	0.4
	13	0.08	12								
	14	0.09	13								
WKL 15 - 12	15	0.16	21	29	M8	52	50	15	36	21	0.8
	17	0.20	24								
	19	0.26	27								
WKL 20 - 12	20	0.29	29	29	M8	60	54	17	42	25	1.0
	22	0.35	32								
	24	0.41	35								
WKL 25 - 12	25	0.49	40	29	M8	66	62	19	48	32	1.3
	27	0.58	43								
	29	0.66	46								
WKL 30 - 12	30	0.77	51	29	M8	76	70	21	56	38	1.9
	32	0.87	55								
	35	1.05	60								

*Hole diameter can be freely chosen within given limitations.

**Locking bolts: DIN EN ISO 4017/4014 grade 10.9 as standard, alternatively DIN EN ISO 4762 grade 10.9

M16 and upwards with washers: DIN EN ISO 7416

When ordering please state: (Type x $\varnothing d_w$ x desired model), e.g. WKL 30 - 12 x 32 x A

Shaft Coupling Type WKL – Series 12

Type	d _w [*] mm	M _t kNm	P _{ax} kN	M _a Nm	B ^{**}	D mm	L mm	h mm	A mm	d ₁ mm	kg
WKL 40 - 12	36	1.3	70	58	M10	96	80	25	70	47	3.5
	40	1.8	92								
	43	2.3	109								
WKL 50 - 12	44	2.3	102	100	M12	112	90	30	84	58	5.5
	50	3.4	137								
	54	4.3	161								
WKL 60 - 12	55	4.1	150	100	M12	120	120	34	94	66	7.9
	60	5.5	183								
	62	6.1	197								
WKL 70 - 12	63	6.2	196	100	M12	148	140	40	112	79	13.7
	70	8.6	245								
	73	9.7	266								
WKL 80 - 12	74	10	282	160	M14	170	170	44	130	94	21.4
	80	13	326								
	85	15	364								
WKL 90 - 12	86	17	387	240	M16	185	200	50	144	104	29.5
	90	19	421								
	95	22	466								
WKL 100 - 12	96	23	487	240	M16	197	210	54	148	114	33.0
	100	26	523								
	106	31	579								
WKL 120 - 12	107	35	659	240	M16	230	230	65	174	134	54.2
	120	48	796								
	125	53	850								
WKL 140 - 12	126	56	895	470	M20	290	250	76	206	160	95.4
	140	74	1064								
	150	89	1188								
WKL 160 - 12	150	82	1096	470	M20	320	280	83	234	180	115
	160	97	1216								
	165	105	1277								
WKL 180 - 12	165	116	1404	470	M20	340	310	94	260	205	152
	180	145	1613								
	185	156	1684								
WKL 200 - 12	185	167	1805	470	M20	370	350	96	266	226	192
	200	203	2034								
	210	230	2190								
WKL 220 - 12	210	234	2224	820	M24	405	390	118	320	246	252
	220	262	2385								
	230	293	2548								
WKL 240 - 12	230	273	2377	820	M24	430	430	128	340	267	302
	240	304	2536								
	250	337	2696								
WKL 260 - 12	240	325	2712	1210	M27	460	450	138	366	288	376
	250	361	2888								
	260	398	3065								
WKL 280 - 12	260	431	3312	1210	M27	485	470	154	400	308	443
	270	473	3504								
	280	518	3698								
WKL 300 - 12	280	537	3834	1210	M27	520	470	162	420	328	502
	290	585	4035								
	300	636	4237								

*Hole diameter can be freely chosen within given limitations.

**Locking bolts: DIN EN ISO 4017/4014 grade 10.9 as standard, alternatively DIN EN ISO 4762 grade 10.9 M16 and upwards with washers: DIN EN ISO 7416

When ordering please state: (Type x Ød_w x desired model), e.g. WKL 240 - 12 x 230 x B

Shaft Coupling Type WKL – Series 12

Type	d _w * mm	M _t kNm	P _{ax} kN	M _a Nm	B**	D mm	L mm	h mm	A mm	d ₁ mm	kg
WKL 320 - 12	300	667	4450	1640	M30	550	510	180	446	348	609
	310	723	4664								
	320	781	4881								
WKL 340 - 12	320	811	5066	1640	M30	590	510	184	466	368	694
	330	874	5294								
	340	939	5525								
WKL 360 - 12	340	973	5725	2210	M33	650	530	192	490	398	881
	350	1043	5961								
	360	1116	6199								
WKL 390 - 12	370	1199	6479	2210	M33	670	580	216	526	428	1004
	380	1278	6725								
	390	1360	6972								
WKL 420 - 12	400	1647	8234	2210	M33	740	600	226	550	448	1257
	410	1746	8517								
	420	1848	8801								
WKL 460 - 12	430	1841	8561	2210	M33	780	640	246	590	498	1483
	450	2050	9112								
	460	2160	9390								
WKL 500 - 12	470	2568	10929	2850	M36	860	690	276	648	540	1989
	480	2700	11249								
	500	2974	11895								
WKL 550 - 12	510	3014	11820	2850	M36	960	760	296	710	600	2739
	530	3301	12456								
	550	3602	13097								
WKL 600 - 12	560	3610	12893	2850	M36	1000	780	310	760	650	2957
	580	3921	13520								
	600	4245	14151								
WKL 650 - 12	620	4555	14695	2850	M36	1080	820	320	824	700	3501
	630	4732	15023								
	650	5097	15684								
WKL 700 - 12	660	5360	16243	2850	M36	1140	840	340	890	760	4056
	680	5751	16916								
	700	6158	17593								
WKL 750 - 12	710	6256	17623	2850	M36	1280	880	360	950	814	5511
	730	6679	18298								
	750	7116	18977								

Further sizes on request, subject to technical changes.

*Hole diameter can be freely chosen within given limitations.

**Locking bolts: DIN EN ISO 4017/4014 grade 10.9 as standard, alternatively DIN EN ISO 4762 grade 10.9

M16 and upwards with washers: DIN EN ISO 7416

When ordering please state: (Type x Ød_w x desired model), e.g. WKL 750 - 12 x 710 x B

You have not found what you are looking for in our comprehensive range of standard-products?
We will be happy to promptly prepare any form of custom-made product and development innovation
even using special materials such as 1.3974. Please feel free to contact us.

Shaft Coupling Type WK and WKL Special Solutions

System Solution W Coupling

Locking unit for the bridging of maximum distances between shafts

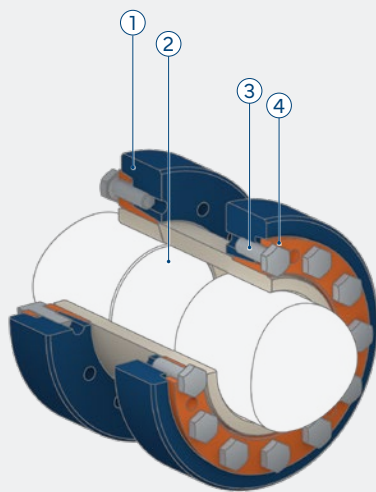

Benefits

- For large distances between shafts
- Rotationally rigid coupling

- ① Outer ring*
- ② Shaft
- ③ Locking bolts* including washer as necessary*
- ④ Inner ring*

*Included with the delivery

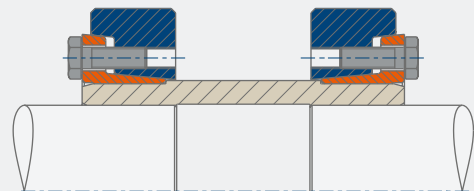

Individual solution WKD

Compact shaft coupling for small distances between shafts

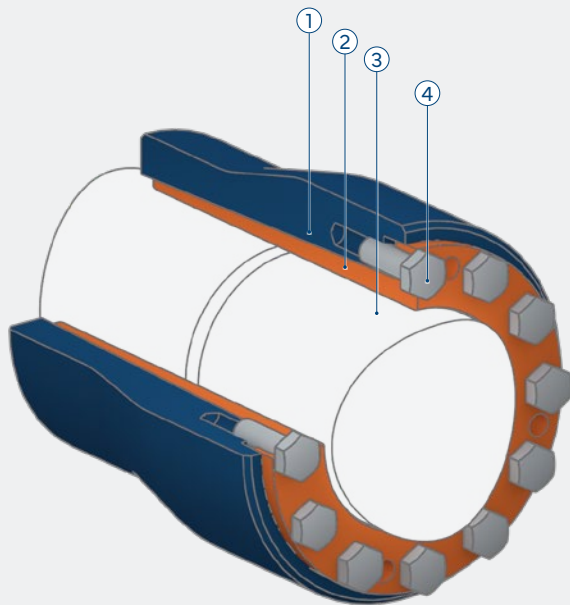

Benefits

- Less components
- Short distances between shafts

- ① Outer ring*
- ② Inner ring*
- ③ Shaft
- ④ Locking bolts* including washer as necessary*

*Included with the delivery

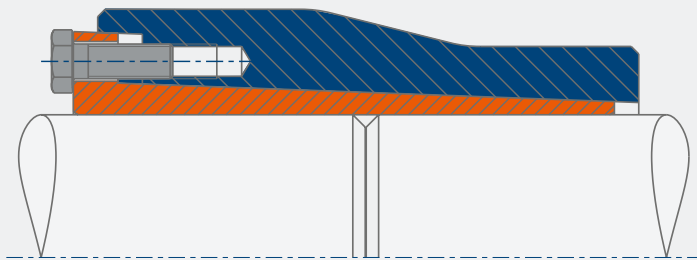

Hydraulic Shaft Coupling WKHYD

Hydraulic shaft coupling for small distances between shafts

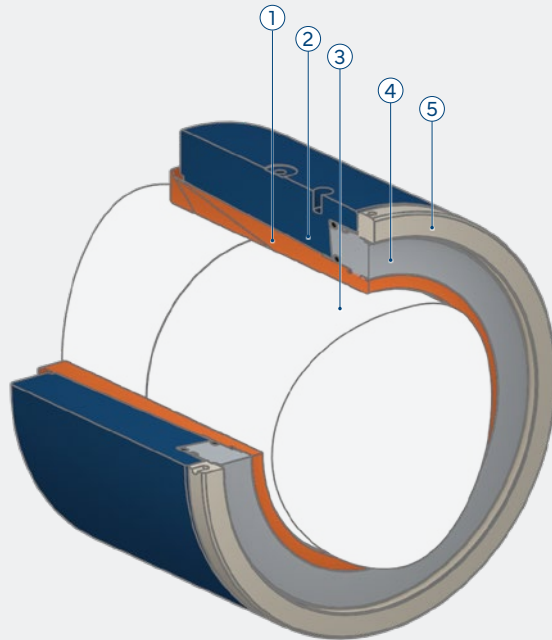

Benefits

- Quicker installation

- ① Inner ring*
- ② Outer ring*
- ③ Shaft
- ④ Support ring*
- ⑤ Nut*

*Included with the delivery

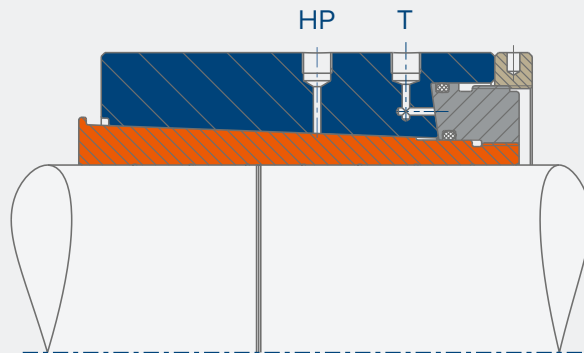

WKL with Spline Shaft Teeth

Locking element for the adaption of a splined shaft with smooth shaft (e.g. in hydraulic motors)

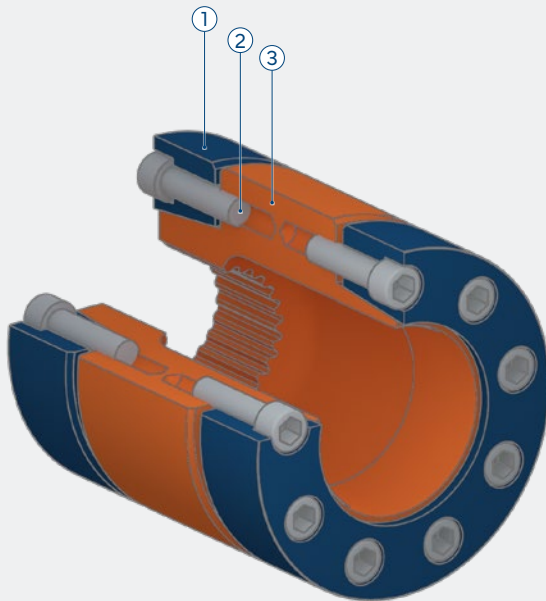

Benefits

- Minimization of wear to the interlocking connection
- Increasing of the service life of the plant shaft

- ① Outer ring*
- ② Locking bolts* including washer as necessary*
- ③ Inner ring*

*Included with the delivery

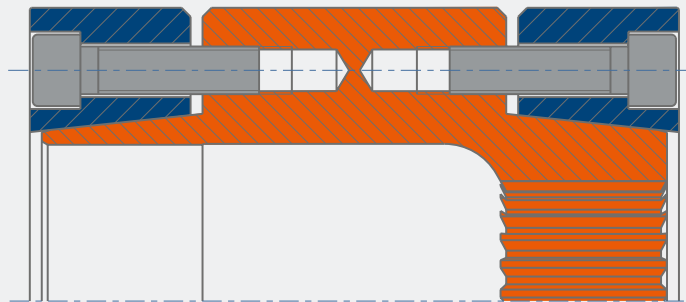

Hydraulic Shaft Coupling WKLHYD

Hydraulic shaft coupling for large distances between shafts

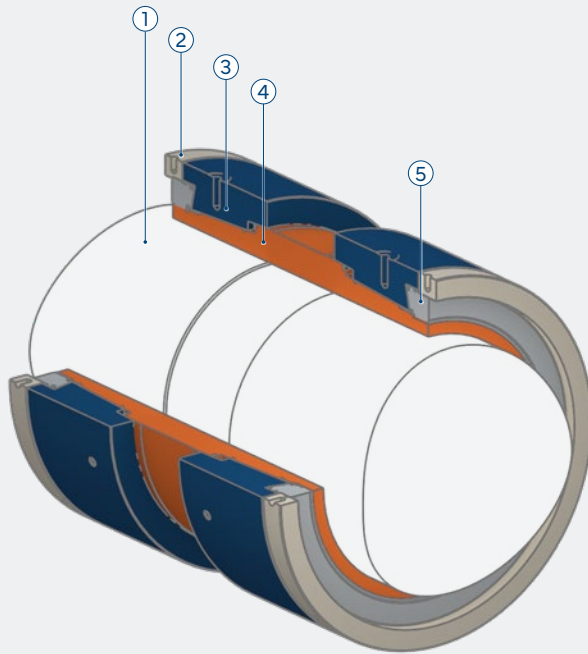

Benefits

- Quicker installation

- ① Shaft
- ② Nut*
- ③ Outer ring*
- ④ Inner ring*
- ⑤ Support ring*

*Included with the delivery

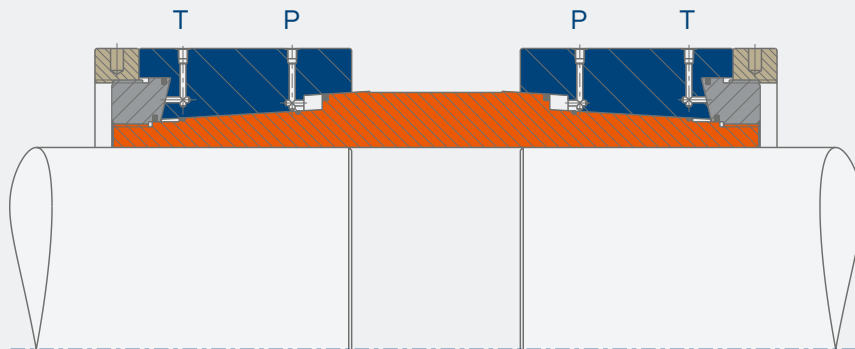

STÜWE[®]



Flange Coupling

Type FKH, FKHA, FKD – Mechanical



Flange coupling Type FKH, FKHA & FKD

General Information

Application Description

Flange couplings are used for the connection of shafts with the aid of a flange. The type FKH flange coupling consists of two flanged halves and thus forms a rigid connection between two shafts. If only one flanged half is needed, STÜWE® offers the type FKHA and FKD flange coupling. The FKD flange coupling is characterized by the tapered design of its flange which enables the saving of fitting tolerance and a reduction in cost and weight thanks to the elimination of one component. All flange couplings provide the possibility for the compensation of length tolerances in the system due to free positioning. Extremely high static and dynamic loads can also be safely transmitted.

Areas of Use



Driveline technology



Steel- & rolling mill equipment



Crushing equipment

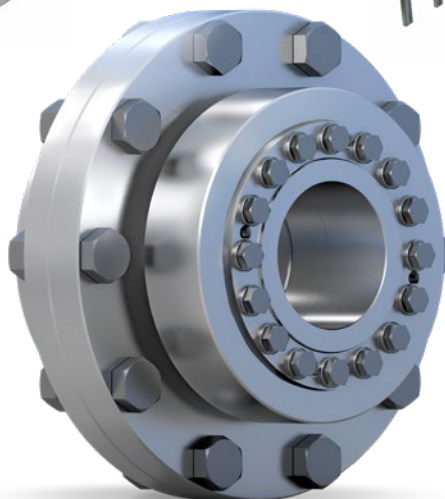

Conveying equipment



Shipbuilding



Wind turbines

Flange Coupling

Type FKH, FKHA and FKD – Series

Description	Shaft diameter	Transmissible torque	Features
FKH	70 - 350 mm	6 - 911 kNm	Complete flange coupling
FKHA	95 - 320 mm	17 - 853 kNm	Flange coupling half
FKD 4	90 - 350 mm	20 - 729 kNm	Flange coupling half, high torques and speed and extremely high bending moments
FKD 6	90 - 350 mm	22 - 911 kNm	Flange coupling half, extremely high torques and speed and high bending moments

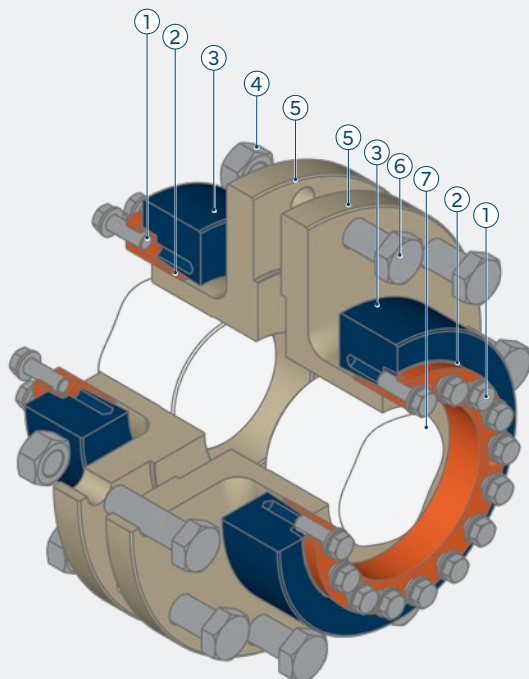

- ① Locking bolts* including washer as necessary*
- ② Inner ring*
- ③ Outer ring*
- ④ Hexagonal nut**
- ⑤ Flange*
- ⑥ Flange bolt**
- ⑦ Shaft

*Included with the delivery

**Only included with the delivery for type FKH

All types may be protected against environmental influences by zinc and nickel coating or by a paint which has an appropriate corrosion protection class. We are able to achieve both desired colours which conform with the RAL colour range and products with lubricants in accordance with NSF H1. More detailed information on this may be found in this catalogue on page 151.

Flange Coupling Type FKH

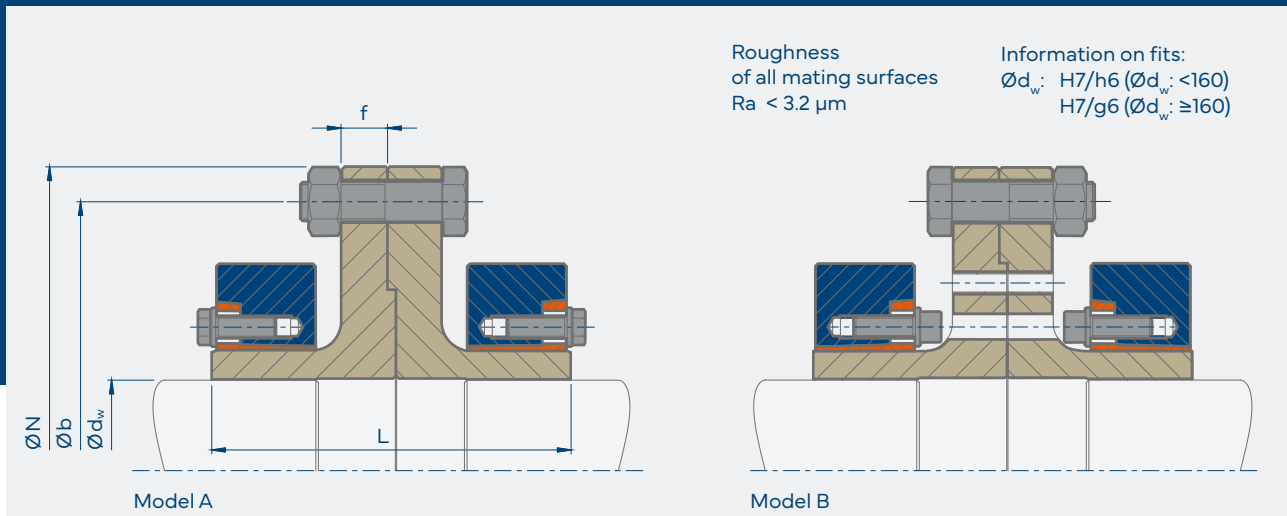

Code

M_t Maximum transmissible torque of a flange coupling for $P_{ax} = 0$

M_a Maximum tightening torque of the locking bolts (see also "Installation and Removal Instructions")

M_{aFL} Tightening torque of the flange connecting bolts

Flange Coupling – Type FKH

Type	d_w^{**} mm	M_t kNm	Shrink Disc	M_a Nm	B^{***}	N mm	b mm	L mm	f mm	Flange bolts*	M_{aFL} Nm	kg
FKH 240 - 80	70	6	HSD 100 - 22	58	M10	240	206	136	18	6 x M16	210	27
	75	7										
	84	10										
FKH 300 - 90	85	12	HSD 125 - 22	100	M12	300	260	160	20	6 x M20	420	47
	95	16										
	100	19										
FKH 340 - 100	95	17	HSD 140 - 22	160	M14	340	280	190	24	5 x M24	720	61
	100	20										
	115	28										
FKH 370 - 110	115	30	HSD 155 - 22	160	M14	370	310	210	24	8 x M24	720	78
	120	33										
	125	36										
FKH 400 - 120	120	37	HSD 165 - 22	240	M16	400	350	228	28	8 x M24	720	110
	125	41										
	135	50										
FKH 400 - 130	130	45	HSD 175 - 22	240	M16	400	350	228	28	8 x M24	720	112
	135	49										
	145	58										
FKH 470 - 140	140	64	HSD 185 - 22	240	M16	470	416	278	36	10 x M30	1450	173
	145	70										
	150	76										
FKH 470 - 150	150	80	HSD 200 - 22	240	M16	470	416	278	36	10 x M30	1450	182
	155	87										
	160	93										

*Grade 10.9 **Hole diameter can be freely chosen within given limitations.

***Locking bolts for Model A: DIN EN ISO 4014/4017 Grade 10.9, Model B: DIN EN ISO 4762 Grade 10.9

When ordering please state: (Type x $\text{Ø}d_w$ x model), e.g. FKH 340 - 100 x 100 x B

Flange Coupling – Type FKH

Type	d _w ** mm	M _t kNm	Shrink Disc	M _a Nm	B***	N mm	b mm	L mm	f mm	Flange bolts*	M _a FL Nm	kg
FKH 520 - 160	160	103	HSD 220 - 22	470	M20	520	456	300	36	12 x M30	1450	245
	165	112										
	170	119										
FKH 560 - 180	170	122	HSD 240 - 22	470	M20	560	496	322	36	16 x M30	1450	302
	180	140										
	190	159										
FKH 560 - 200	190	163	HSD 260 - 22	470	M20	560	496	350	36	16 x M30	1450	334
	200	184										
	210	207										
FKH 590 - 220	210	215	HSD 280 - 22	470	M20	590	526	392	40	18 x M30	1450	420
	220	240										
	230	267										
FKH 630 - 240	220	271	HSD 300 - 22	820	M24	630	570	408	40	18 x M30	1450	494
	230	300										
	240	331										
FKH 630 - 250	240	301	HSD 320 - 22	820	M24	630	570	408	40	18 x M30	1450	534
	250	332										
	260	364										
FKH 710 - 260	250	390	HSD 340 - 22	820	M24	710	656	450	40	24 x M30	1450	717
	260	427										
	270	466										
FKH 710 - 280	270	496	HSD 360 - 22	820	M24	710	656	450	40	24 x M30	1450	754
	280	539										
	290	584										
FKH 800 - 300	290	640	HSD 390 - 22	1210	M27	800	736	500	50	28 x M30	1450	1006
	300	691										
	320	800										
FKH 800 - 330	320	742	HSD 420 - 22	1210	M27	800	736	540	50	28 x M30	1450	1158
	330	797										
	350	911										

Further sizes on request, subject to technical changes.

*Grade 10.9 **Hole diameter can be freely chosen within given limitations.

***Locking bolts for Model A: DIN EN ISO 4014/4017 Grade 10.9, Model B: DIN EN ISO 4762 Grade 10.9

When ordering please state: (Type x Ød_w x Model), e.g. FKH 630 - 250 x 240 x A

Flange Coupling Type FKHA

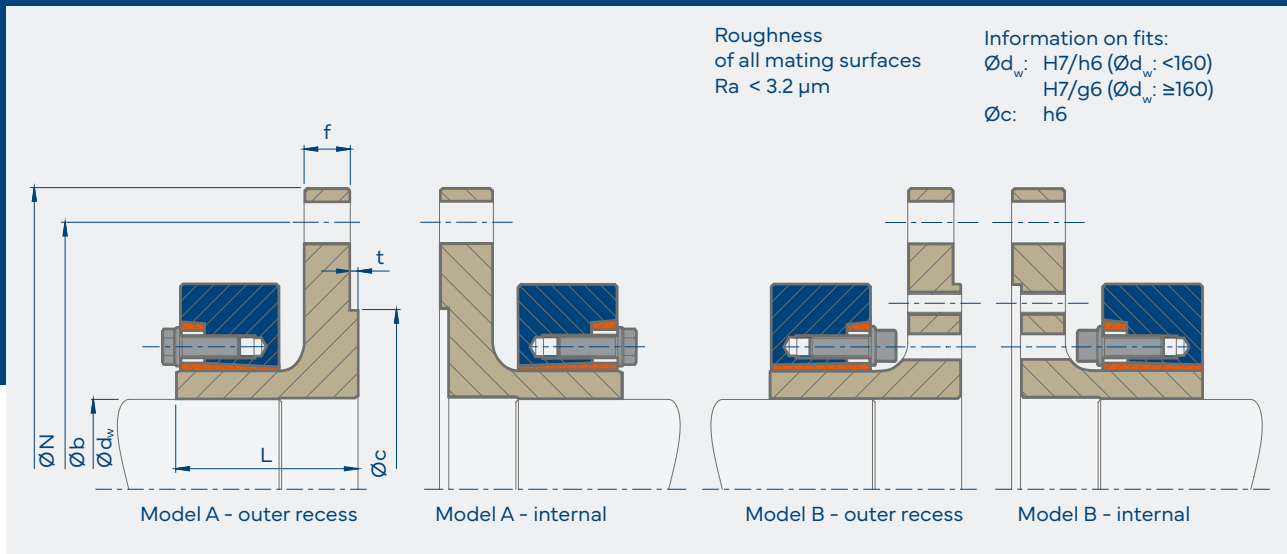

Code

- M_t Maximum transmissible torque of a flange coupling for $P_{ax} = 0$
 M_a Maximum tightening torque of the locking bolts (see also "Installation and Removal Instructions")
 M_{aFL} Tightening torque of the flange connecting bolts

Dimensions N, b, c, t plus quantity and size of flange bolts depend on the counterflange and can be changed if necessary. Please state the desired dimensions where they vary from the value in the table.

Flange Coupling – Type FKHA

Type	d_w^{**} mm	M_t kNm	Shrink Disc	M_a Nm	B ^{***}	N mm	b mm	c mm	L mm	f mm	t mm	Flange bolts*	M_{aFL} Nm	kg
FKHA 340 - 100	95	17	HSD 140 - 22	160	M14	340	280	200	98	24	6	5 x M24	720	28
	100	19												
	110	24												
FKHA 370 - 120	115	30	HSD 155 - 22	160	M14	370	310	220	114	30	6	8 x M24	720	40
	120	33												
	125	36												
FKHA 400 - 120	120	37	HSD 165 - 22	240	M16	400	350	250	114	30	6	8 x M24	720	50
	125	41												
	130	45												
FKHA 400 - 130	130	45	HSD 175 - 22	240	M16	400	350	250	114	30	6	8 x M24	720	51
	135	49												
	145	58												
FKHA 470 - 140	140	64	HSD 185 - 22	240	M16	470	416	280	142	36	6	10 x M30	1450	80
	145	70												
	150	76												
FKHA 470 - 150	150	80	HSD 200 - 22	240	M16	470	416	280	142	36	6	10 x M30	1450	84
	155	87												
	160	93												

*Grade 10.9 **Hole diameter can be freely chosen within given limitations

***Locking bolts for Model A: DIN EN ISO 4014/4017 Grade 10.9, Model B: DIN EN ISO 4762 Grade 10.9

When ordering please state: (Type x $\varnothing d_w$ x model), such as FKHA 400 - 130 x 135 x B, possible dimensions of N, b, c, t, quantity & size of the flange bolts

Flange Coupling – Type FKHA

Type	d _w ** mm	M _t kNm	Shrink Disc	M _a Nm	B***	N mm	b mm	c mm	L mm	f mm	t mm	Flange bolts*	M _a FL Nm	kg
FKHA 520 - 160	160	103	HSD 220 - 22	470	M20	520	456	320	154	36	8	12 x M30	1450	112
	165	112												
	170	119												
FKHA 560 - 180	170	122	HSD 240 - 22	470	M20	560	496	360	165	36	8	16 x M30	1450	137
	180	140												
	190	159												
FKHA 560 - 200	190	163	HSD 260 - 22	470	M20	560	496	360	179	36	8	16 x M30	1450	152
	200	184												
	210	207												
FKHA 590 - 220	210	215	HSD 280 - 22	470	M20	590	526	380	200	40	8	18 x M30	1450	184
	220	240												
	230	267												
FKHA 630 - 250	230	272	HSD 320 - 22	820	M24	630	570	430	208	40	8	18 x M30	1450	239
	250	332												
	260	364												
FKHA 710 - 280	260	455	HSD 360 - 22	820	M24	710	656	480	229	40	8	24 x M30	1450	338
	280	539												
	290	584												
FKHA 800 - 300	290	640	HSD 390 - 22	1210	M27	800	736	520	254	50	8	28 x M30	1450	451
	300	691												
	320	800												
FKHA 800 - 330	320	742	HSD 420 - 22	1210	M27	800	736	550	274	50	8	28 x M30	1450	513
	330	797												
	340	853												

Further sizes on request, subject to technical changes.

*Grade 10.9 **Hole diameter can be freely chosen within given limitations.

***Locking bolts for Model A: DIN EN ISO 4014/4017 Grade 10.9, Model B: DIN EN ISO 4762 Grade 10.9

When ordering please state: (Type x Ød_w x model), such as FKHA 590 - 220 x 225 x A, possible dimensions of N, b, c, t, quantity & size of the flange bolts

You have not found what you are looking for in our comprehensive range of standard-products?
We will be happy to promptly prepare any form of custom-made product and development innovation
even using special materials such as 1.3974. Please feel free to contact us.

Flange Coupling Type FKH, FHKA and FKD

Special Solutions

Flange Coupling FK with SD

Connection element with three-part shrink disc for compact installation spaces

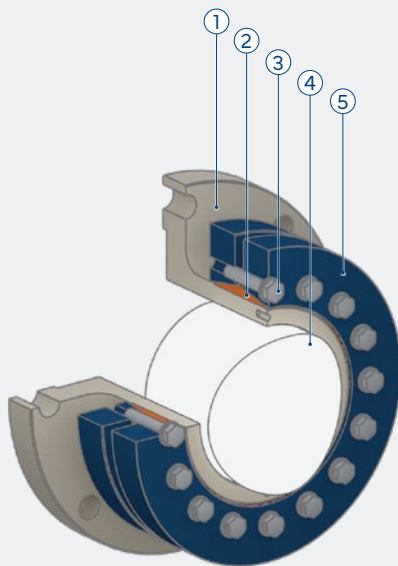

Benefits

- Low space requirement
- Free positioning
- Compensation of length tolerance variations possible

- ① Flange*
- ② Inner ring*
- ③ Locking bolts* including washer as necessary*
- ④ Shaft
- ⑤ Outer ring*

*Included with the delivery

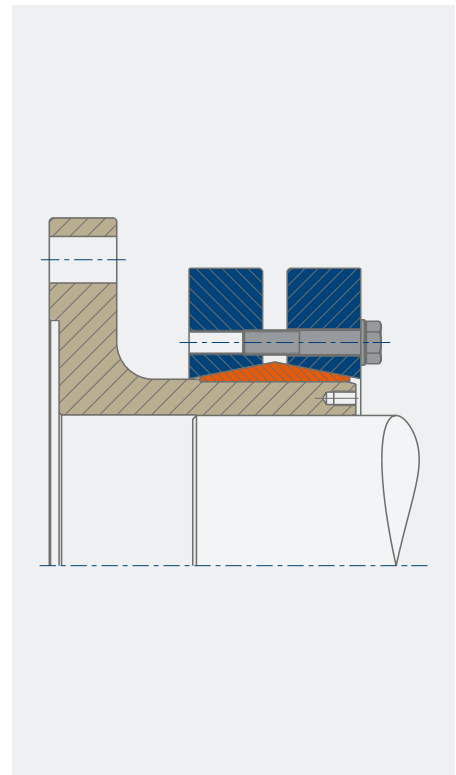

Flange Coupling Type FKD

Series 4

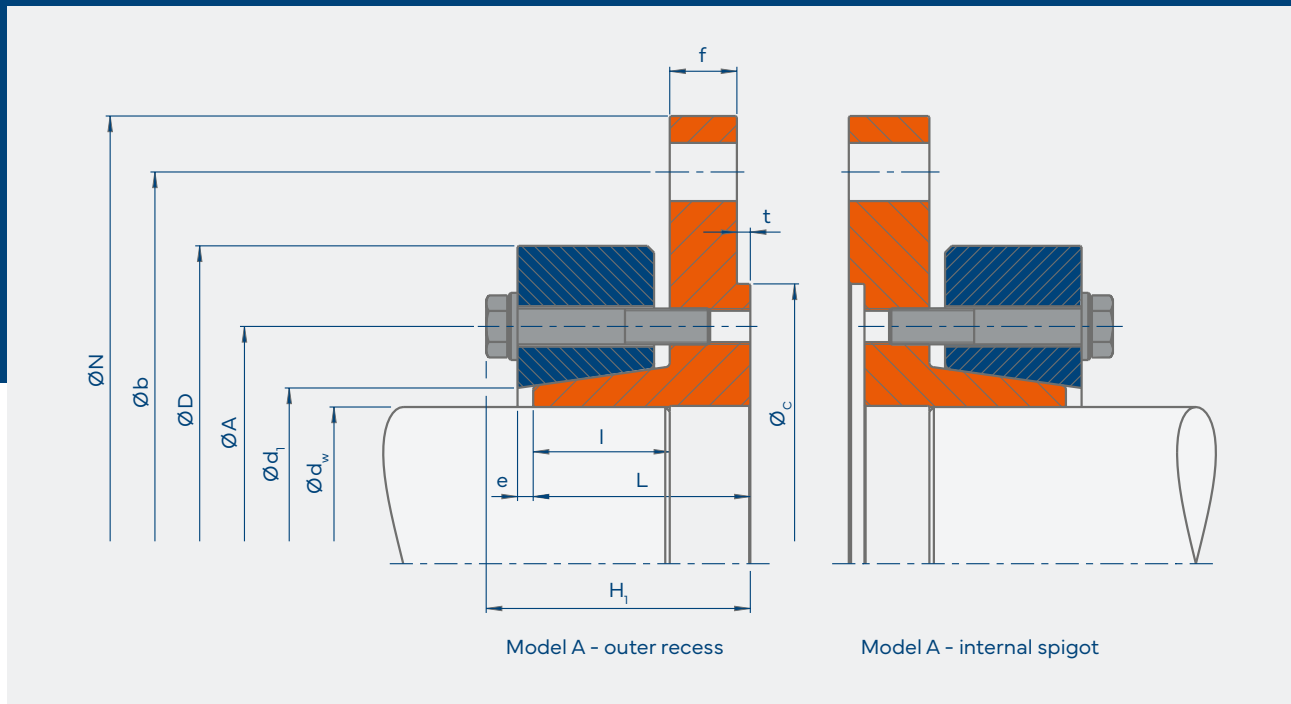

Flange Coupling Type FKD – Series 4

Type	d_w^{**} mm	Mt Nm	B ^{***}	M_a Nm	D mm	l mm	H_1 mm	A mm	d_1 mm	e mm
FKD 4 - 340 - 90	90	20103	8 x M14	193	217	52	92	168	123	5.5
	100	26093								
	110	30800								
FKD 4 - 370 - 110	110	40511	10 x M14	193	248	61	107	184	137	7
	115	45015								
	120	49777								
FKD 4 - 400 - 120	120	51080	9 x M16	295	280	61	113	202	150	6.5
	125	55641								
	130	61041								
FKD 4 - 400 - 130	130	57456	9 x M16	295	284	61	113	212	157	7
	135	61600								
	140	61600								
FKD 4 - 470 - 140	140	85814	10 x M16	295	297	82	140	227	172	10
	145	93185								
	150	100885								

Further sizes on request, subject to technical changes.

*Grade 10.9

**The hole diameter can be freely chosen within given limitations.

***Model A locking bolts: DIN EN ISO 4014/4017 grade 12.9, model B: DIN EN ISO 4762 Grade 12.9

****Continuous bending moment

When ordering please state for the recess shape of the outer recess: m

the following applies: $t_f = t + l$

When ordering please state for the recess shape of the inner recess: f

the following applies: $t_m = t$

When ordering please state: (Type x $\varnothing d_w$ x model - recess shape), e.g. FKD4-400-130x135xA-m

Flange Coupling Type FKD

Series 4

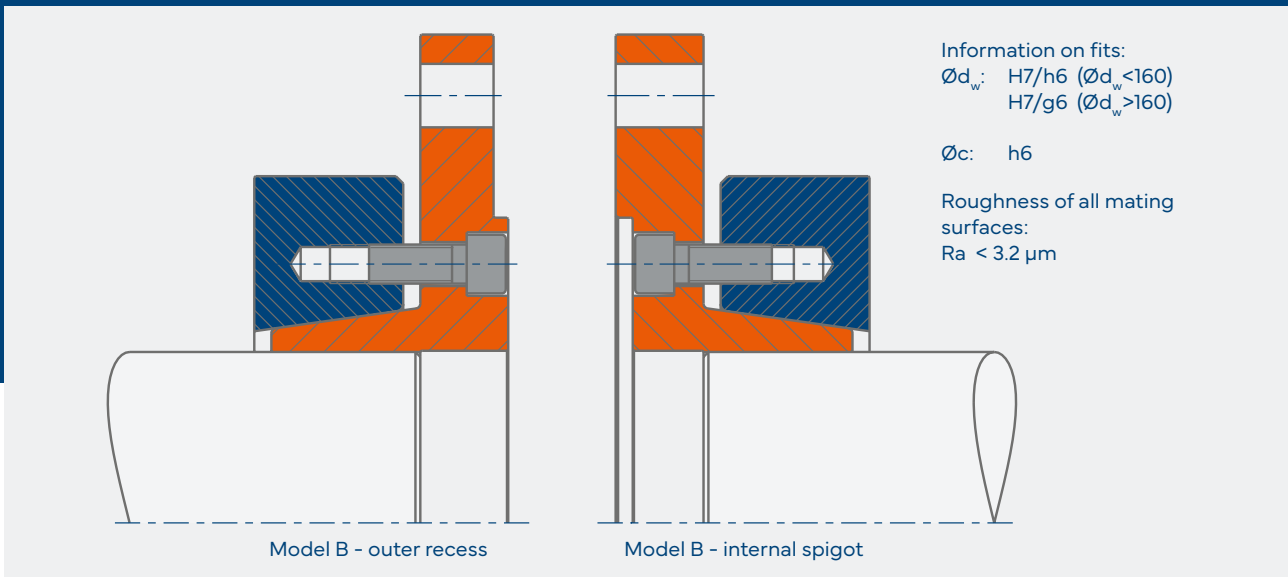

Code

M_t Maximum transmissible torque of a shaft coupling for $P_{ax} = 0$

P_{ax} Maximum transmissible axial load of a shaft coupling for $M_t = 0$

M_a Maximum tightening torque of the locking bolts (see also "Installation and Removal Instructions")

The dimensions H_1 and e apply to units in a non-tensioned condition.

N	b	c	L	f	t	Flange-bolts*	M_a	Mass	$M_{br, con}^{****}$	n_{max}
mm	mm	mm	mm	mm	mm		Nm	kg	Nm	1/min
340	280	200	82	24	6	5 x M24	720	29	2700	8500
								29	3900	
								27	5500	
370	310	220	97	30	6	8 x M24	720	43	5800	7800
								42	6700	
								41	7700	
400	350	250	97	30	6	8 x M24	720	53	7900	6700
								52	9000	
								51	10000	
400	350	250	97	30	6	8 x M24	720	52	9700	6500
								51	11000	
								50	12000	
470	416	280	124	36	6	10 x M30	1450	81	11000	6400
								80	13000	
								79	14000	

Flange Coupling Type FKD – Series 4

Type	d_w^{**} mm	Mt Nm	B ^{***}	M_a Nm	D mm	l mm	H_1 mm	A mm	d_1 mm	e mm
FKD 4 - 470 - 150	150	103053	9 x M20	570	332	83	143	249	183	8
	155	111179								
	160	119638								
FKD 4 - 520 - 160	160	133380	9 x M20	570	327	104	166	261	194	11
	165	143284								
	170	153572								
FKD 4 - 560 - 170	170	160288	10 x M20	570	372	110	185	293	223	14.5
	180	180830								
	190	205052								
FKD 4 - 560 - 190	190	219540	10 x M24	900	406	118	185	320	239	14.5
	200	247024								
	210	276254								
FKD 4 - 590 - 210	210	273476	12 x M24	900	454	114	183	349	262	11
	220	303773								
	230	335167								
FKD 4 - 630 - 220	220	303042	10 x M27	1310	454	125	198	362	268	13.5
	230	335257								
	240	363204								
FKD 4 - 630 - 240	240	353650	10 x M27	1310	472	125	198	381	286	16
	250	363204								
	260	363204								
FKD 4 - 710 - 250	250	482284	10 x M30	1800	535	140	213	408	306	15.5
	260	526671								
	270	557338								
FKD 4 - 710 - 270	270	524565	10 x M30	1800	540	140	213	429	322	15
	280	557338								
	290	557338								
FKD 4 - 800 - 290	290	682955	10 x M30	1800	597	146	249	455	349	23.5
	300	729523								
	310	729523								
FKD 4 - 800 - 310	310	729523	10 x M30	1800	618	146	251	478	368	24.5
	320	729523								
	330	729523								
FKD 4 - 800 - 330	330	729523	10 x M30	1800	610	152	235	496	383	23.5
	340	729523								
	350	729523								

Further sizes on request, subject to technical changes.

*Grade 10.9

**The hole diameter can be freely chosen within given limitations.

***Model A locking bolts: DIN EN ISO 4014/4017 grade 12.9, model B: DIN EN ISO 4762 Grade 12.9

****Continuous bending moment

When ordering please state for the recess shape of the outer recess: m

the following applies: $t_f = t + 1$

When ordering please state for the recess shape of the inner recess: f

the following applies: $t_m = t$

When ordering please state: (Type x $\varnothing d_w$ x model - recess shape), e.g. FKD4-400-130x135xA-m

N	b	c	L	f	t	Flange- bolts*	M _a	Mass	M _{br} con****	nmax
mm	mm	mm	mm	mm	mm		Nm	kg	Nm	1/min
470	416	300	125	36	6	10 x M30	1450	91	14000	5600
								89	16000	
								88	18000	
520	456	320	148	36	8	12 x M30	1450	110	16000	5700
								108	18000	
								107	19000	
560	496	370	154	36	8	16 x M30	1450	142	19000	5200
								139	23000	
								135	28000	
560	496	370	162	36	8	16 x M30	1450	159	28000	4600
								155	33000	
								151	39000	
590	526	400	162	40	8	18 x M30	1450	193	40000	4200
								189	46000	
								184	53000	
630	570	430	173	40	8	18 x M30	1450	213	42000	4200
								209	49000	
								204	56000	
630	570	440	173	40	8	18 x M30	1450	216	54000	3900
								211	61000	
								206	69000	
710	656	480	188	40	8	24 x M30	1450	309	68000	3500
								303	77000	
								297	87000	
710	656	490	188	40	8	24 x M30	1450	302	80000	3400
								295	90000	
								289	101000	
800	736	520	204	50	8	28 x M30	1450	424	107000	3200
								417	120000	
								409	133000	
800	736	540	204	50	8	28 x M30	1450	432	128000	3100
								424	142000	
								416	157000	
800	736	560	210	50	8	28 x M30	1450	417	138000	3300
								408	153000	
								399	168000	

Please note when selecting flange couplings that the transmission values given in the table are reference values for orientation.

Attention:

An overlapping of speed, bending moment and torque leads to a reduction in the transmissible torque.

Should several loads of the size of those limits given in the table be applied at the same time on the shrink disc in your case, please feel free to contact our Design department at engineering@stuewe.de.

Flange Coupling Type FKD

Series 6

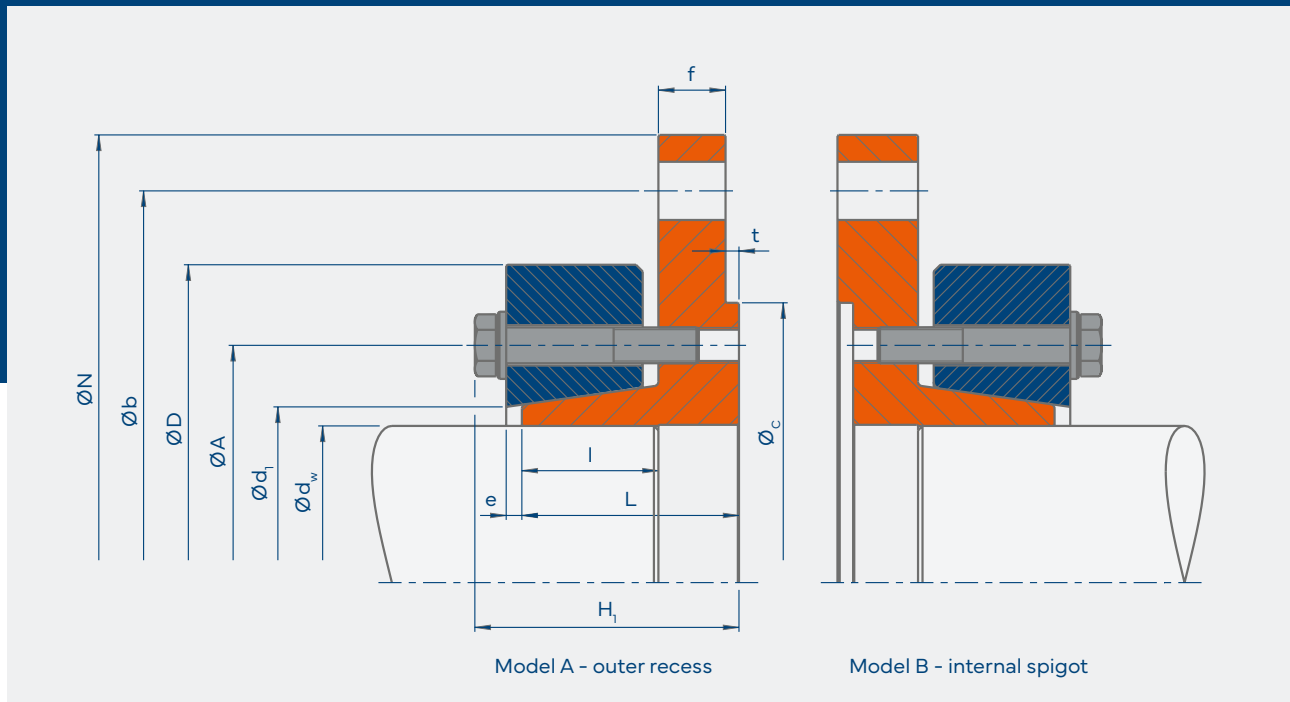

Flange Coupling Type FKD – Series 6

Type		d_w^{**} mm	M_t Nm	B^{***}	M_a Nm	D mm	l mm	H_1 mm	A mm	d_1 mm	e mm
FKD 6 -	340 - 90	90	22352	9 x M14	193	198	72	112	169	123	6.5
		100	29356								
		110	36960								
FKD 6 -	370 - 110	110	44686	10 x M14	193	229	77	123	185	138	8.5
		115	49767								
		120	55146								
FKD 6 -	400 - 120	120	57410	9 x M16	295	253	82	134	201	149	8
		125	62601								
		130	68869								
FKD 6 -	400 - 130	130	68736	9 x M16	295	267	82	134	212	158	9
		135	75267								
		140	77000								
FKD 6 -	470 - 140	140	93661	10 x M16	295	270	105	163	227	171	12
		145	101926								
		150	110571								

Further sizes on request, subject to technical changes.

*Grade 10.9

**The hole diameter can be freely chosen within given limitations.

***Model A locking bolts: DIN EN ISO 4014/4017 grade 12.9, model B: DIN EN ISO 4762 Grade 12.9

****Continuous bending moment

When ordering please state for the recess shape of the outer recess: m | the following applies: $tf = t + 1$

When ordering please state for the recess shape of the inner recess: f | the following applies: $tm = t$

When ordering please state: (Type x $\varnothing d_w$ x model - recess shape), e.g. FKD6-400-130x135xA-m

Flange Coupling Type FKD

Series 6

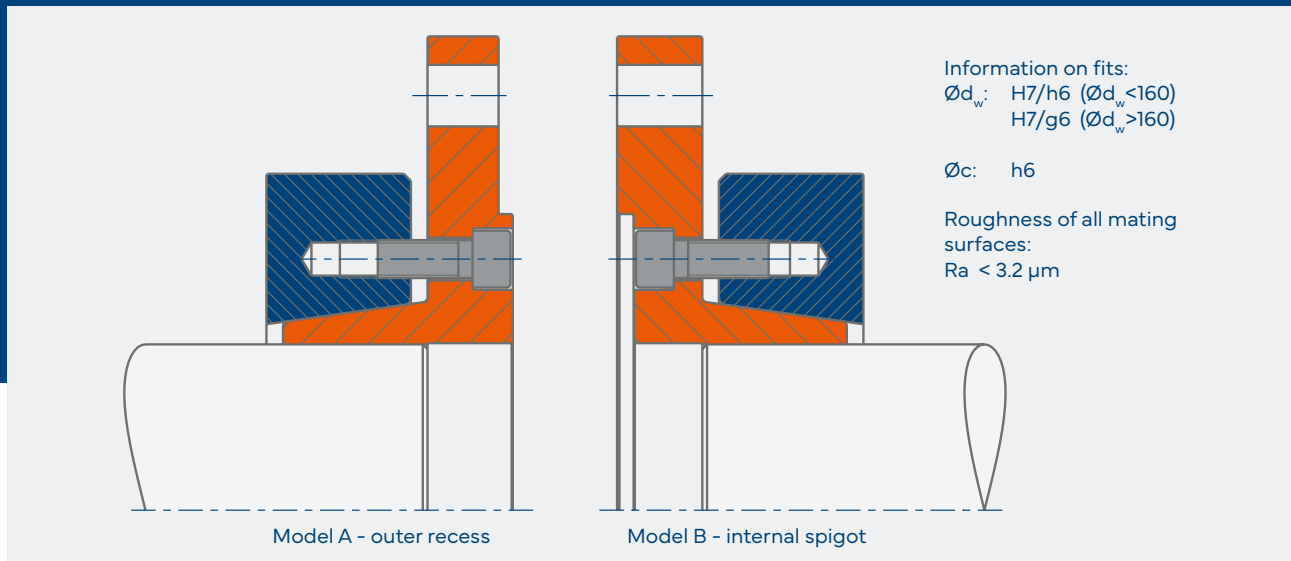

Code

M_t Maximum transmissible torque of a shaft coupling for $P_{ax} = 0$

P_{ax} Maximum transmissible axial load of a shaft coupling for $M_t = 0$

M_a Maximum tightening torque of the locking bolts (see also "Installation and Removal Instructions")

The dimensions H_1 and e apply to units in a non-tensioned condition.

N	b	c	L	f	t	Flange- bolts*	M_a Nm	Mass kg	$M_{br, con}^{****}$ Nm	nmax 1/min
mm	mm	mm	mm	mm	mm					
340	280	200	102	24	6	6 x M24	720	31	2200	9000
								30	3200	
								28	3000	
370	310	220	113	30	6	9 x M24	720	43	5000	8300
								43	5900	
								42	6800	
400	350	250	118	30	6	10 x M24	720	54	6600	7600
								53	7500	
								52	8600	
400	350	250	118	30	6	10 x M24	720	55	8600	7100
								54	9800	
								53	11000	
470	416	280	147	36	6	8 x M30	1450	81	9900	7000
								80	11000	
								78	12000	

Flange Coupling Type FKD – Series 6

Type	d_w^{**} mm	Mt Nm	B ^{***}	M _a Nm	D mm	l mm	H ₁ mm	A mm	d ₁ mm	e mm
FKD 6 - 470 - 150	150	112829	9 x M20	570	304	105	165	248	181	9
	155	121931								
	160	131416								
FKD 6 - 520 - 160	160	144336	10 x M20	570	304	132	194	263	193	10.5
	165	155321								
	170	166743								
FKD 6 - 560 - 170	170	173284	10 x M20	570	329	141	203	285	215	15
	180	196117								
	190	223227								
FKD 6 - 560 - 190	190	235336	10 x M24	900	377	144	209	319	238	15
	200	265371								
	210	297359								
FKD 6 - 590 - 210	210	304458	10 x M24	900	424	140	209	346	262	16.5
	220	338624								
	230	372408								
FKD 6 - 630 - 220	220	349594	10 x M27	1310	441	150	221	364	271	15
	230	386915								
	240	426273								
FKD 6 - 630 - 240	240	421405	10 x M27	1310	472	150	221	387	293	18
	250	459585								
	260	502686								
FKD 6 - 710 - 250	250	525703	10 x M30	1800	492	176	249	408	306	18.5
	260	574927								
	270	626522								
FKD 6 - 710 - 270	270	587217	10 x M30	1800	520	168	241	430	325	19
	280	637623								
	290	673450								
FKD 6 - 800 - 290	290	772582	10 x M30	1800	572	177	260	458	351	24
	300	833182								
	310	833741								
FKD 6 - 800 - 310	310	833741	10 x M30	1800	595	177	260	478	368	25
	320	833741								
	330	833741								
FKD 6 - 800 - 330	330	911904	10 x M30	1800	606	177	260	500	387	26
	340	911904								
	350	911904								

Further sizes on request, subject to technical changes.

*Grade 10.9

**The hole diameter can be freely chosen within given limitations.

***Model A locking bolts: DIN EN ISO 4014/4017 grade 12.9, model B: DIN EN ISO 4762 Grade 12.9

****Continuous bending moment

When ordering please state for the recess shape of the outer recess: m
the following applies: $t_f = t + 1$

When ordering please state for the recess shape of the inner recess: f
the following applies: $t_m = t$

When ordering please state: (Type x $\varnothing d_w$ x model - recess shape), e.g. FKD6-400-130x135xA-m

N	b	c	L	f	t	Flange- bolts*	M _a	Mass	M _{b, con****}	n _{max}
mm	mm	mm	mm	mm	mm		Nm	kg	Nm	1/min
470	416	280	147	36	6	9 x M30	1450	91	12000	6400
								90	14000	
								88	15000	
520	456	320	176	36	8	12 x M30	1450	112	13000	6400
								110	15000	
								109	17000	
560	496	360	185	36	8	16 x M30	1450	137	16000	5900
								133	19000	
								128	23000	
560	496	360	188	36	8	18 x M30	1450	160	24000	5000
								155	29000	
								150	34000	
590	526	380	188	40	8	20 x M30	1450	196	36000	4600
								191	42000	
								186	48000	
630	570	430	198	40	8	22 x M30	1450	227	40000	4300
								221	47000	
								216	54000	
630	570	430	198	40	8	25 x M30	1450	242	53000	4000
								236	60000	
								230	69000	
710	656	480	224	40	8	27 x M30	1450	311	59000	3900
								304	67000	
								297	76000	
710	656	480	216	40	8	29 x M30	1450	317	75000	3700
								310	84000	
								303	94000	
800	736	520	235	50	8	32 x M30	1450	444	100000	3400
								436	112000	
								427	124000	
800	736	520	235	50	8	32 x M30	1450	456	122000	3300
								447	135000	
								438	149000	
800	736	520	235	50	8	35 x M30	1450	452	138000	3200
								442	153000	
								432	168000	

Please note when selecting flange couplings that the transmission values given in the table are reference values for orientation.

Attention:

An overlapping of speed, bending moment and torque leads to a reduction in the transmissible torque.

Should several loads of the size of those limits given in the table be applied at the same time on the shrink disc in your case, please feel free to contact our Design department at engineering@stuewe.de.

STÜWE[®]



Flange Coupling

Type FKHYD – Hydraulic

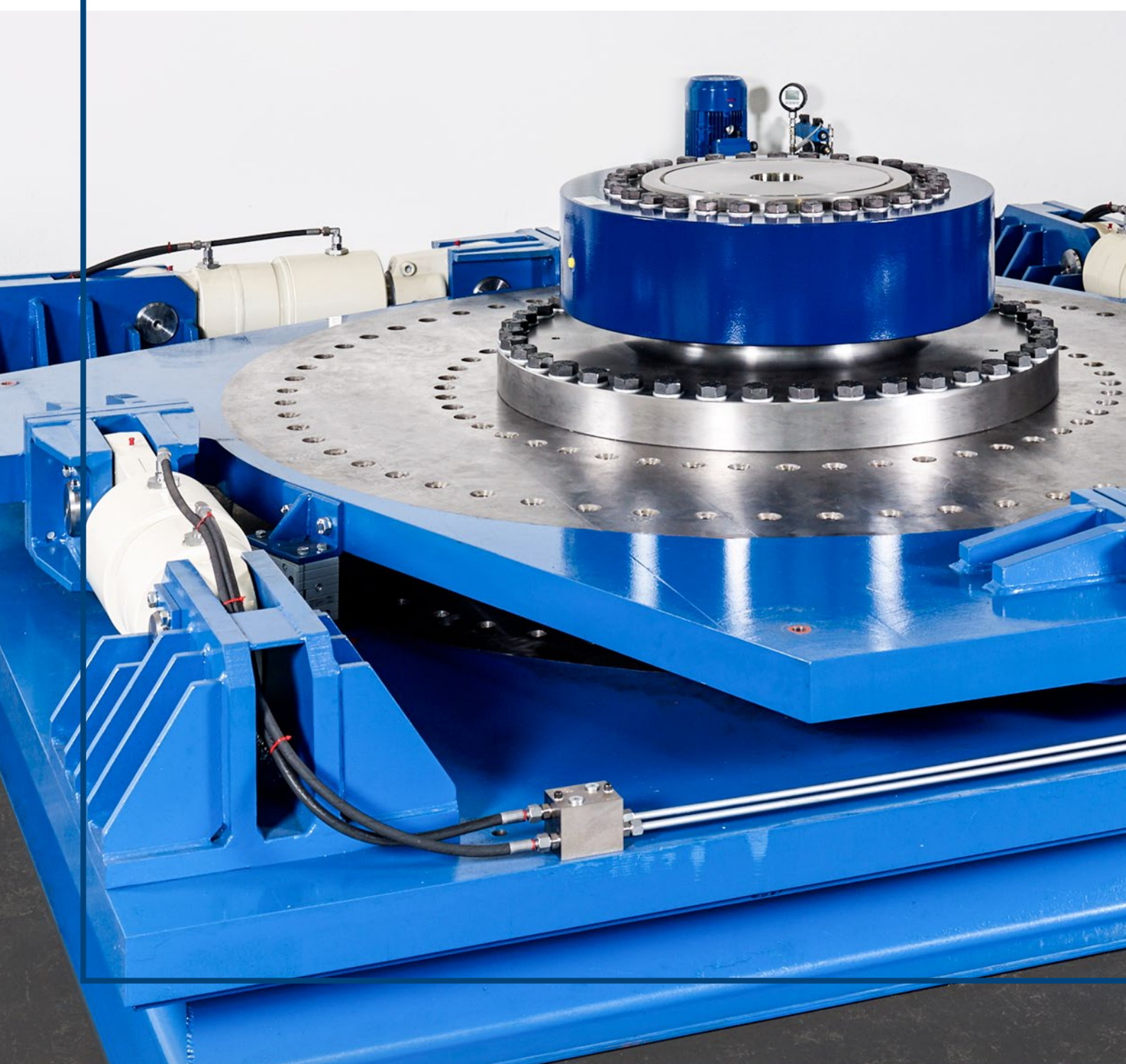

Flange Coupling Type FKHYD

General Information

Application Description

Flange couplings are used for the connection of shafts with the aid of a flange. The FKHYD is a hydraulic flange coupling half which combines the benefits of all the flange couplings to be found in the STÜWE® range (length tolerances may be compensated by free positioning, transmission of extremely high static and dynamic loads) with a minimized installation time. The reduction in the installation time is made possible by the hydraulic locking principle of the coupling in which bolts which are subject to bending moments are eliminated.

Areas of Use



Driveline technology



Steel- & rolling mill equipment

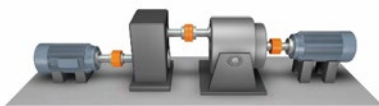

Measurement & testing equipment



Conveying equipment

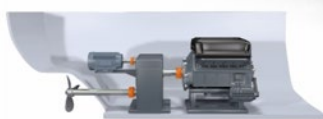

Shipbuilding



Wind turbines

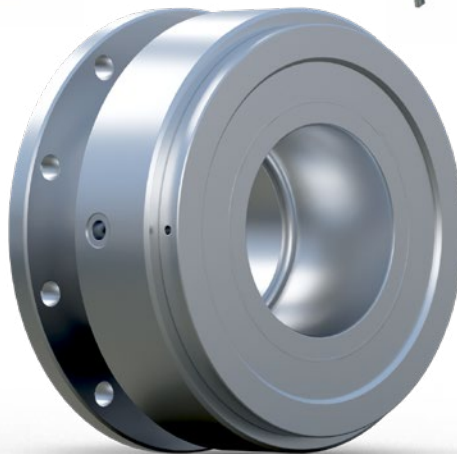



Flange Coupling

Type FKHYD – Series

Description	Shaft diameter	Transmissible torque	Features
FKHYD	120 - 440 mm	40 - 2300 kNm	Transmission of extremely high torques hydraulic design

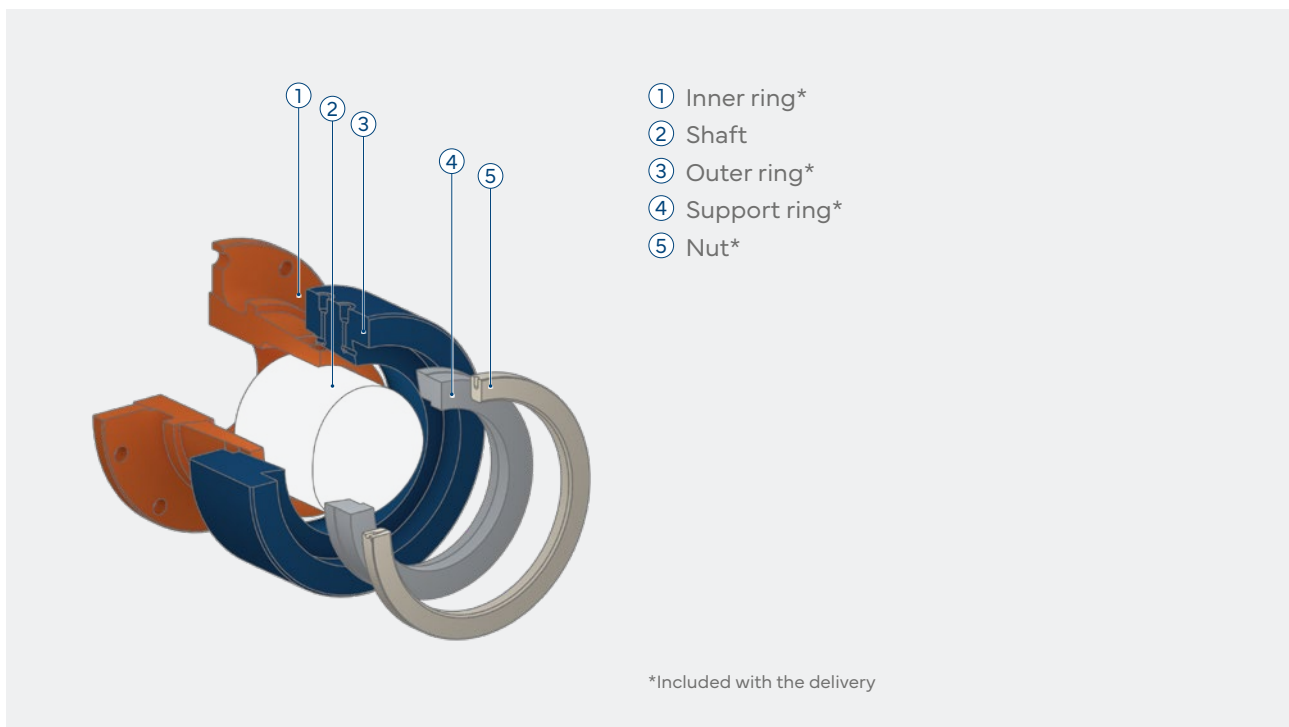

All types may be protected against environmental influences by zinc and nickel coating or by a paint which has an appropriate corrosion protection class. We are able to achieve both desired colours which conform with the RAL colour range and products with lubricants in accordance with NSF H1. More detailed information on this may be found in this catalogue on page 151.

Flange Coupling Type FKHYD

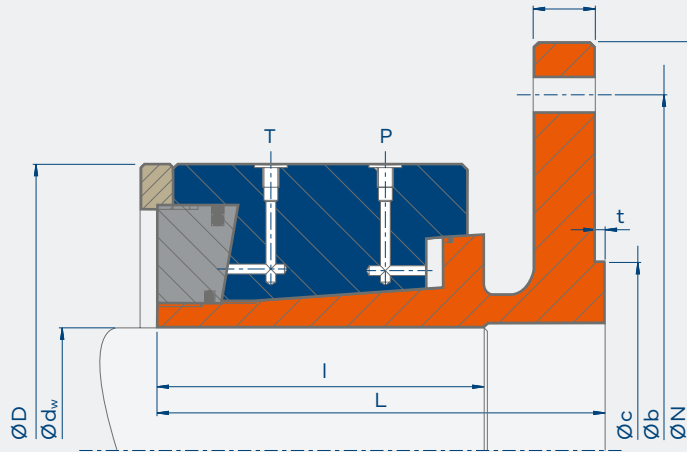

Information on fits:

$\text{Ø}d_w$: H7/h6 ($\text{Ø}d_w < 160$)
H7/g6 ($\text{Ø}d_w \geq 160$)

$\text{Ø}c$: h6

Roughness of all mating surfaces:
 $R_a < 3.2 \mu\text{m}$

T Clamping pressure is a maximum of 450 bar

P Release pressure is 450 bar

Code

M_t Maximum transmissible torque of a flange coupling for $P_{ax} = 0$

Dimensions N, b, c, t plus quantity and size of flange bolts depend on the counterflange.

When ordering please state Flanges can also be supplied counterbored for internal spigot location.

Flange Coupling – Type FKHYD

Type	d_w^* mm	M_t kNm	N mm	D mm	L mm	l mm	f mm	kg
FKHYD 400 - 120	120	40	400	300	150	90	30	69
	130	48						
	140	57						
FKHYD 470 - 160	150	87	470	340	185	117	36	111
	160	101						
	170	115						
FKHYD 520 - 180	170	115	520	370	185	117	36	131
	180	130						
	190	147						
FKHYD 560 - 200	190	167	560	430	210	140	36	189
	200	186						
	210	208						
FKHYD 590 - 220	220	248	590	460	240	160	40	234
	230	275						
	240	304						
FKHYD 630 - 240	240	360	630	520	260	180	40	319
	250	394						
	260	430						
FKHYD 710 - 260	260	435	710	570	310	220	40	455
	270	474						
	280	515						

*Hole diameter can be freely chosen within given limitations

When ordering please state: (Type x $\text{Ø}d_w$), e.g. FKHYD 470 - 160 x 155, dimensions of N, b, c, t, quantity & size of the flange bolts

Flange Coupling – Type FKHYD

Type	d _w * mm	M _t kNm	N mm	D mm	L mm	I mm	f mm	kg
FKHYD 800 - 300	290	765	800	640	320	220	50	611
	300	832						
	310	901						
FKHYD 900 - 340	330	850	900	720	360	255	50	857
	340	910						
	360	1030						
FKHYD 1000 - 380	360	1016	1000	760	368	260	50	996
	380	1147						
	400	1270						
FKHYD 1100 - 420	400	1915	1100	850	420	290	50	1342
	420	2100						
	440	2300						

Further sizes on request, subject to technical changes.

*Hole diameter can be freely chosen within given limitations

When ordering please state: (Type x Ø d_w), e.g. FKHYD 900 - 340 x 360, dimensions of N, b, c, t, quantity & size of the flange bolts

You have not found what you are looking for in our comprehensive range of standard-products?
We will be happy to promptly prepare any form of custom-made product and development innovation
even using special materials such as 1.3974. Please feel free to contact us.

Flange Coupling Type FKHYD

Special Solutions

FKHYD-12 hydraulic flange coupling

Hydraulic flange coupling primarily for the maritime sector

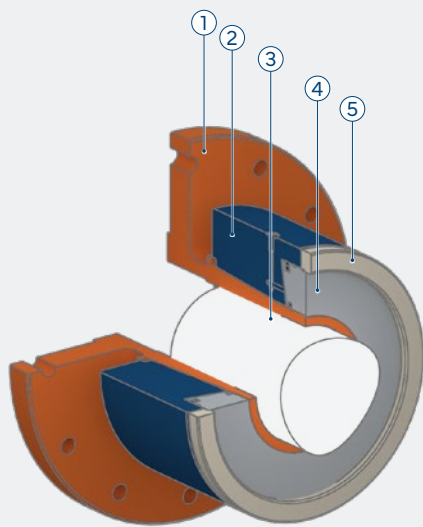

Benefits

- Reduced installation time (compared with FKHA – mechanical)
- Inner ring with tapered design
- More compact design than FKHYD-22

- ① Inner ring*
- ② Outer ring*
- ③ Shaft
- ④ Support ring*
- ⑤ Nut*

*Included with the delivery

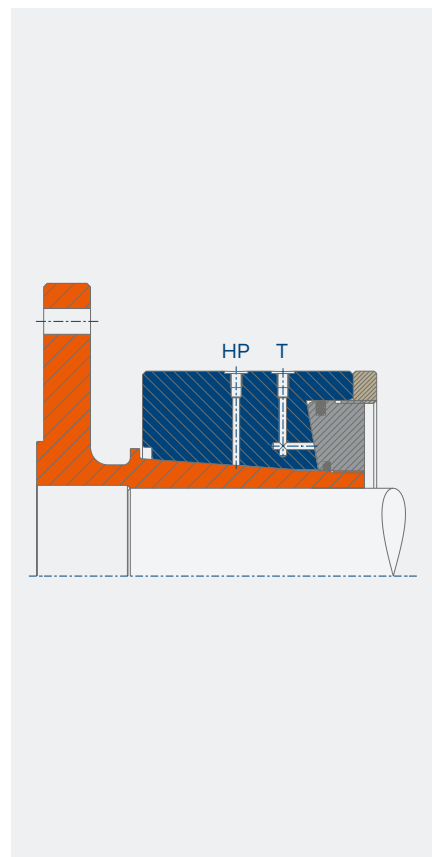

STÜWE[®]

Cardan Shaft Connecting Flange

Type GF

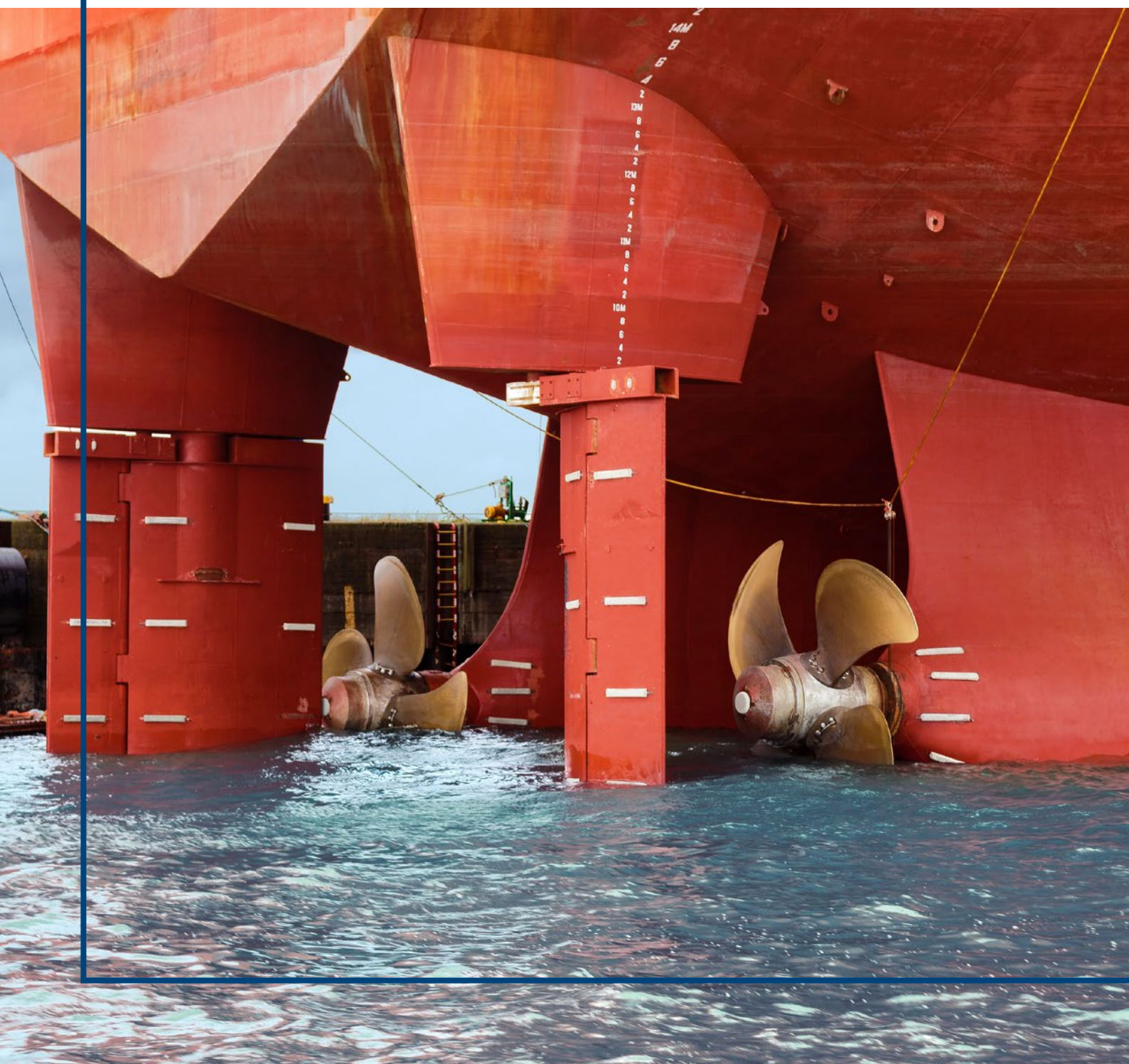

Cardan Shaft Connecting Flange Type GF

General Information

Application Description

The type GF cardan shaft connecting flange is suited for the connection of standard cardan shafts to cylindrical shaft ends. It is characterized by optimal power transmission, easy installation and safe connection in cases of varying or jerky torques. Differentiation is made in the standard delivery programme between three series (21, 22, 23) each with two models so that an optimum variance exists for the achievement of your ideal connection.

Areas of Use



Driveline
technology



Measurement &
testing equipment

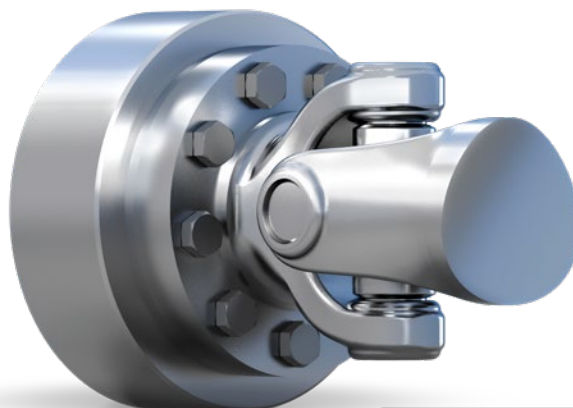

Steel- &
rolling mill equipment

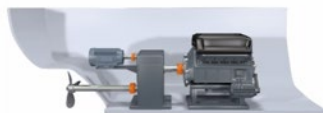

Shipbuilding



Conveying
equipment

STÜWE®

Cardan Shaft Connecting Flange Type GF – Series

Series 21

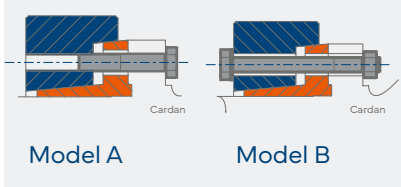

Model A

Model B

Series 22

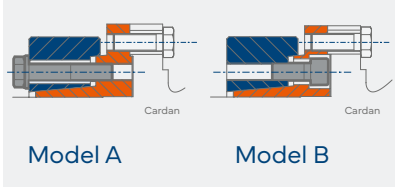

Model A

Model B

Series 23

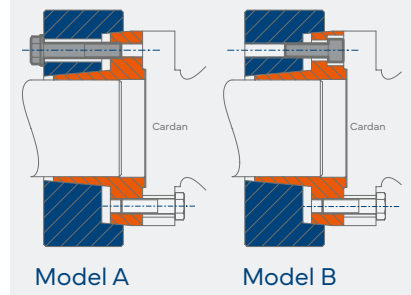

Model A

Model B

Description	Shaft diameter	Transmissible torque	Features
21	20 - 85 mm	0.12 - 9.52 kNm	Flange bolts are also used for tensioning
22	65 - 220 mm	7 - 229 kNm	Primarily for the connection of small shaft end diameters with large cardan shaft flanges
23	90 - 300 mm	13 - 507 kNm	Primarily for the connection of large shaft end diameters

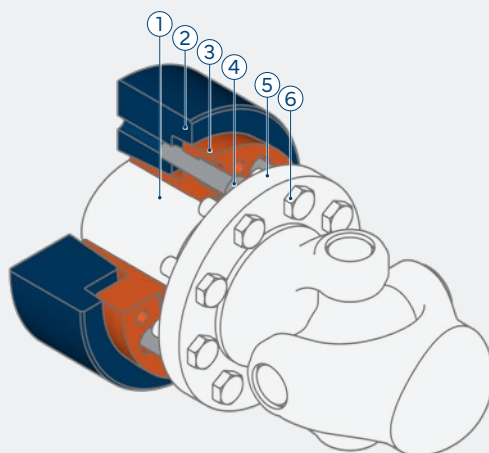

- ① Shaft
- ② Outer ring*
- ③ Inner ring*
- ④ Locking bolts* including washer as necessary*
- ⑤ Cardan Shaft
- ⑥ Flange bolts

*Included with the delivery

All types may be protected against environmental influences by zinc and nickel coating or by a paint which has an appropriate corrosion protection class. We are able to achieve both desired colours which conform with the RAL colour range and products with lubricants in accordance with NSF H1. More detailed information on this may be found in this catalogue on page 151.

Cardan Shaft Connecting Flange Type GF Series 21

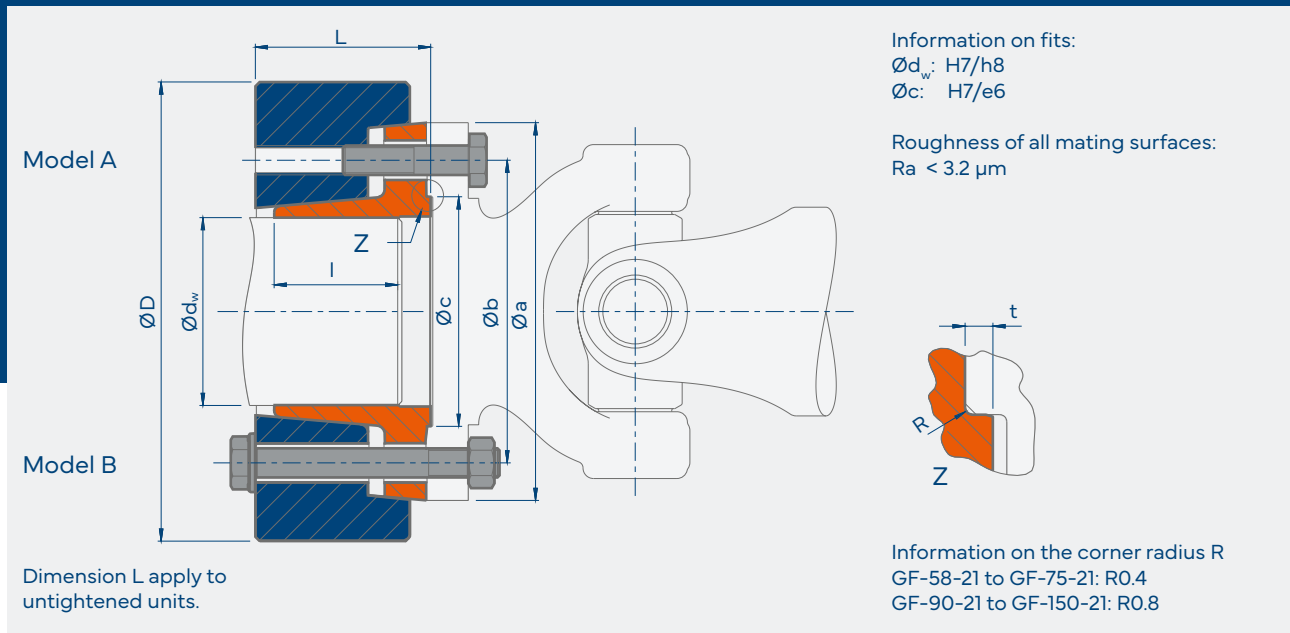

Code

- M_t Maximum transmissible torque of a connecting flange for $P_{ax} = 0$
 P_{ax} Maximum transmissible axial load of a connecting flange for $M_t = 0$
 M_a Maximum tightening torque of the locking bolts (see also "Installation and Removal Instructions")

Cardan Shaft Coupling Type GF – Series 21

Type	d_w^* mm	M_t kNm	D mm	l mm	L mm	a mm	b mm	c mm	t mm	Flange bolts**	M_a Nm	kg
GF 58 - 21	20	0.12	60	18	22	58	47	30	1.3	4 x M5	9	0.5
	24	0.17										
	28	0.24										
GF 65 - 21	20	0.16	72	20	24	65	52	35	1.5	4 x M6	14.5	0.9
	24	0.22										
	30	0.33										
GF 75 - 21	25	0.29	80	22	27	75	62	42	1.8	6 x M6	14.5	1.2
	30	0.41										
	40	0.66										
GF 90 - 21	30	0.38	100	26	31	90	74.5	47	2	4 x M8	35	1.8
	40	0.59										
	45	0.80										
GF 100 - 21	40	0.80	115	26	32	100	84	57	2	6 x M8	35	2.4
	50	1.17										
	55	1.54										
GF 120 - 21	40	1.73	138	28	35	120	101.5	75	2	8 x M10	70	4.0
	60	3.03										
	70	4.24										
GF 150 - 21	50	4.00	170	39	47	150	130	90	2.5	8 x M12	120	7.0
	70	6.53										
	85	9.52										

Further sizes on request, subject to technical changes. *Hole diameter can be freely chosen within given limitations. **Grade 12.9
 Connecting dimensions can be adapted if desired. Model B: M16 and upwards with washers: DIN EN ISO 7416

When ordering please state: (Type x $\varnothing d_w$ x model), e.g. GF 120 - 21 x 60 x A

Additional: holes, bolt size and bolt quantity if different from that given in the table

Cardan Shaft Connecting Flange Type GF Series 22

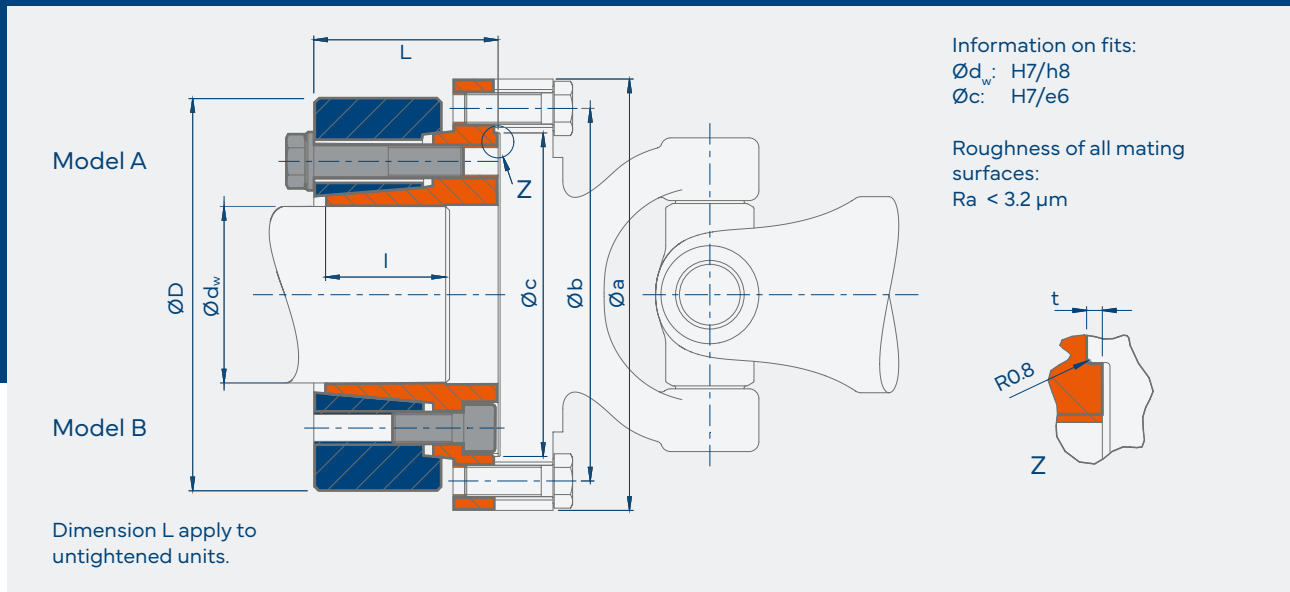

Code

- M_t Maximum transmissible torque of a connecting flange for $P_{ax} = 0$
- P_{ax} Maximum transmissible axial load of a connecting flange for $M_t = 0$
- M_a Maximum tightening torque of the locking bolts (see also "Installation and Removal Instructions")

Cardan Shaft Coupling Type GF – Series 22

Type	d_w^* mm	M_t kNm	Locking bolts Size of	M_a Nm	D mm	I mm	L mm	a mm	b mm	c mm	t mm	Flange bolts**	M_a Nm	kg
GF 180 - 22	65	7	M14	160	170	40	71	180	155.5	110	2	8 x M14	160	10.5
	75	10												
	85	15												
GF 225 - 22	80	12	M16	240	197	51	86	225	196	140	4	8 x M16	240	17.7
	90	17												
	100	24												
GF 250 - 22	90	18	M16	240	215	54	91	250	218	140	4	8 x M18	340	22.5
	100	25												
	110	33												
GF 285 - 22	90	20	M20	470	230	62	102	285	245	175	5	8 x M20	470	31.6
	110	34												
	120	43												
GF 315 - 22	110	37	M24	820	290	73	122	315	280	175	5	8 x M22	640	52.4
	130	58												
	140	71												
GF 350 - 22	130	52	M24	820	320	83	137	350	310	220	7	10 x M22	640	71.2
	160	91												
	180	124												
GF 390 - 22	160	95	M24	820	370	104	154	390	345	250	7	10 x M24	820	100.0
	180	131												
	200	172												
GF 435 - 22	180	136	M27	1210	405	115	181	435	385	280	8	10 x M27	1210	132.6
	200	179												
	220	229												

Further sizes on request, subject to technical changes. *Hole diameter can be freely chosen within given limitations. **Grade 10.9
Connecting dimensions can be adapted if desired. Model A: M16 and upwards with washers: DIN EN ISO 7416

When ordering please state: (Type x $\varnothing d_w$ x model), e.g. GF 250 - 22 x 100 x A

Additional: holes, bolt size and bolt quantity if different from that given in the table

Cardan Shaft Coupling Type GF – Series 23

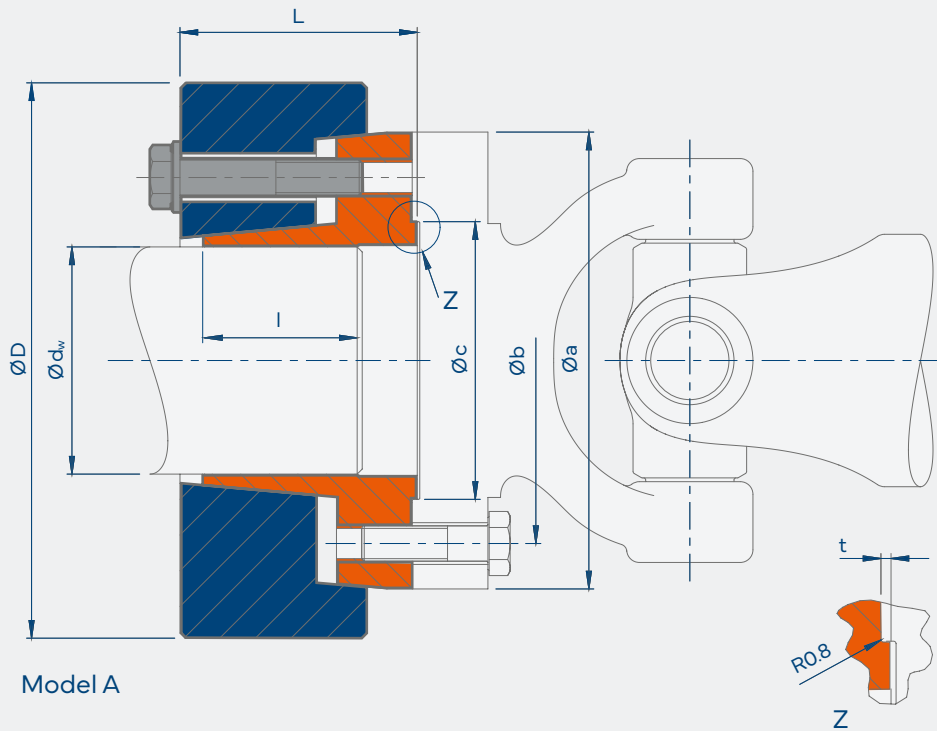

Information on fits:

$\text{Ø}d_w$: H7/h8

$\text{Ø}c$: H7/e6

Roughness
of all mating surfaces
 $Ra < 3.2 \mu\text{m}$

Dimension L apply to
untightened units.

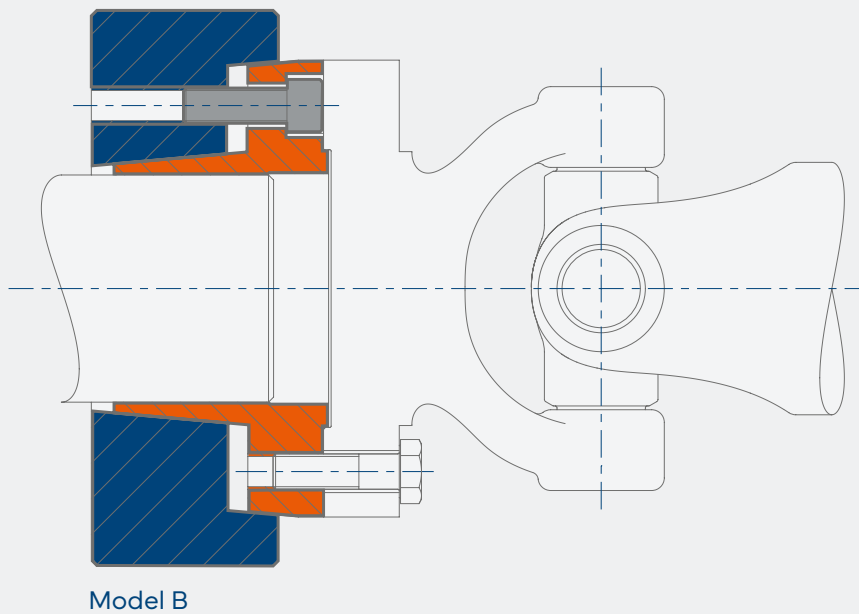

Code

M_t Maximum transmissible torque of a connecting flange for $P_{ax} = 0$

P_{ax} Maximum transmissible axial load of a connecting flange for $M_t = 0$

M_a Maximum tightening torque of the locking bolts (see also "Installation and Removal Instructions")

Cardan Shaft Coupling Type GF – Series 23

Type	d _w * mm	M _t kNm	Locking bolts Size of	M _a Nm	D mm	l mm	L mm	a mm	b mm	c mm	t mm	Flange bolts**	M _a Nm	kg
GF 180 - 23	90	13	M14	160	215	42	76	180	155.5	110	2.5	8 x M14	160	14.8
	110	23												
	120	29												
GF 225 - 23	110	26	M16	240	263	50	87	225	196	140	4	8 x M16	240	24.9
	130	41												
	150	60												
GF 250 - 23	120	35	M16	240	300	61	99	250	218	140	5	8 x M18	340	35.6
	150	65												
	170	90												
GF 285 - 23	130	56	M20	470	320	74	117	285	245	175	5	8 x M20	470	49.1
	160	94												
	180	127												
GF 315 - 23	150	81	M24	820	370	88	138	315	280	175	5	8 x M22	640	80.2
	180	131												
	200	171												
GF 350 - 23	190	147	M24	820	430	103	155	350	310	220	7	10 x M22	640	113.0
	220	213												
	240	265												
GF 390 - 23	210	213	M24	820	460	123	177	390	345	250	7	10 x M24	820	146.5
	240	298												
	260	363												
GF 435 - 23	230	262	M27	1210	520	128	192	435	385	280	7	10 x M27	1210	206.0
	260	356												
	300	507												

Further sizes on request, subject to technical changes.

*Hole diameter can be freely chosen within given limitations. **Grade 10.9

Connecting dimensions can be adapted if desired.

Model A: M16 and upwards with washers: DIN EN ISO 7416

When ordering please state: (Type x Ød_w x model), e.g. GF 250 - 23 x 150 x A

Additional: holes, bolt size and bolt quantity if different from that given in the table

You have not found what you are looking for in our comprehensive range of standard-products?
We will be happy to promptly prepare any form of custom-made product and development innovation
even using special materials such as 1.3974. Please feel free to contact us.

Cardan Shaft Coupling Type GF Special Solutions

GF with Cross Keyway on the Facing Side

easy-to-install cardan shaft connecting flange

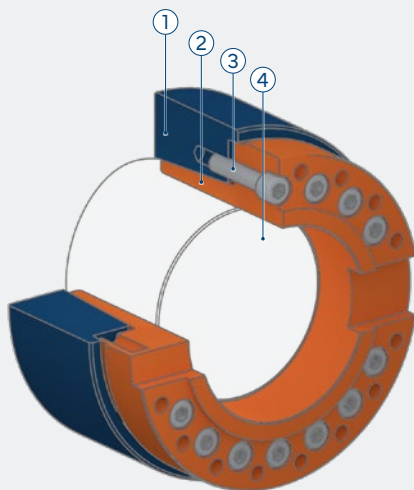

Benefits

- Transmission of high torques
- Simplification of positioning

- ① Outer ring*
- ② Inner ring*
- ③ Locking bolts* including washer as necessary*
- ④ Shaft

*Included with the delivery

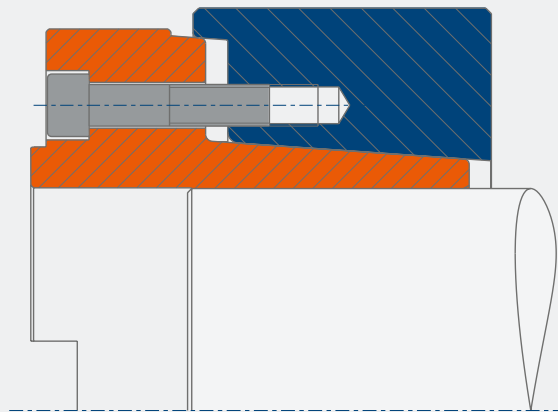

GFHYD with Hirth gearing

Optimal positioning thanks to teeth on the face

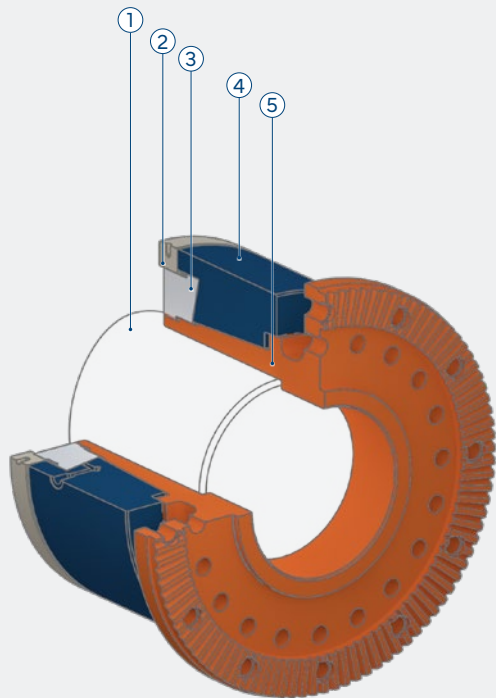

Benefits

- Reduced installation time
- Simplified positioning
- Transmission of high torques

- ① Shaft
- ② Nut*
- ③ Support ring*
- ④ Outer ring*
- ⑤ Inner ring*

*Included with the delivery

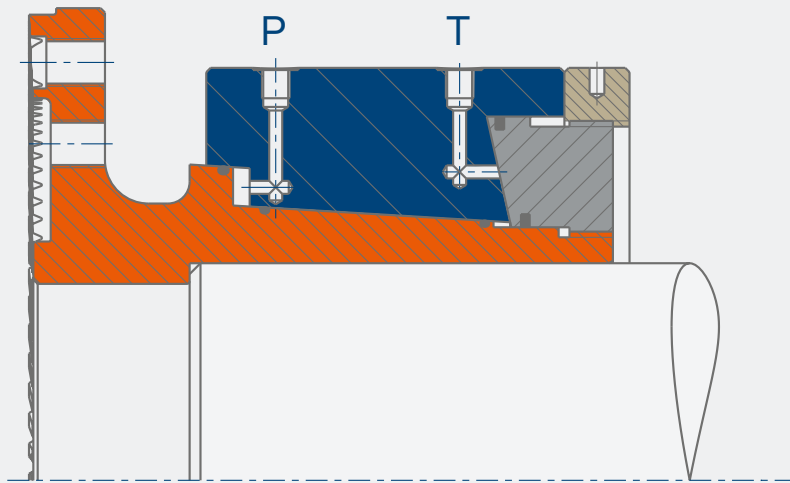

STÜWE[®]



Internal locking Unit

Type IS



Internal locking unit Type IS

General Information

Application Description

Internal locking units are examples of shaft-hub connections. They achieve a frictional and backlash-free connection between a shaft and a hub hole. Due to the locking unit which grips from the inside no additional installation space is taken up by external components outside the hub and slim design is thus permitted. Each type offers the following benefits as a result: It has self-locking taper angles, is self-centring and thus achieves an increase in concentricity through pre-centring.

Areas of Use

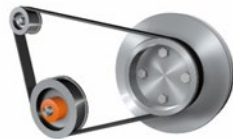

Driveline technology



Crushing equipment

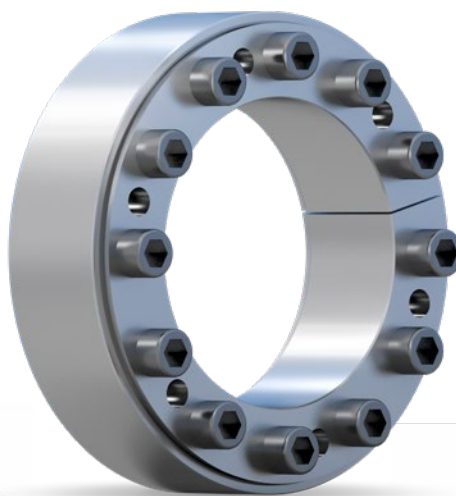

Steel- & rolling mill equipment



Agitation & mixing equipment



Conveying equipment

Internal locking unit

Type IS – Series

Description	Shaft diameter	Transmissible torques*	Features
IS1	20 - 500 mm	0.3 - 880 kNm	Small installation space Sliding of the hub when tensioning
ISN1	20 - 500 mm	0.3 - 723 kNm	Axial fixing No sliding of the hub when tensioning
IS2	70 - 600 mm	7.3 - 1258.5 kNm	For high torques, no sliding of the hub when tensioning
IS3	45 - 600 mm	3.1 - 1458.6 kNm	For extremely high torques, no sliding of the hub when tensioning
IS4	70 - 600 mm	0.9 - 1266 kNm	For high torques, no sliding of the hub when tensioning
IS4.1	100 - 600 mm	11 - 903 kNm	Reduced surface pressure Especially suited for conveyor pulleys No sliding of the hub when tensioning

*all torques are based on an assumed coefficient of friction of 0.12

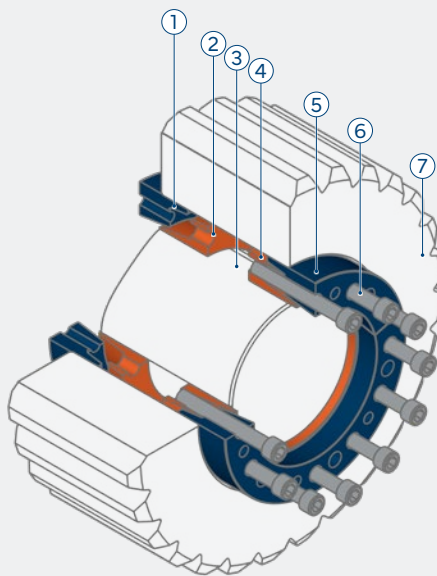

- ① Outer ring 1*
- ② Inner ring 1*
- ③ Shaft
- ④ Inner ring 2*
- ⑤ Outer ring 2*
- ⑥ Locking bolts*
- ⑦ Hub (e.g. gearwheel)

*Included with the delivery

Internal locking unit Type IS Series IS 1

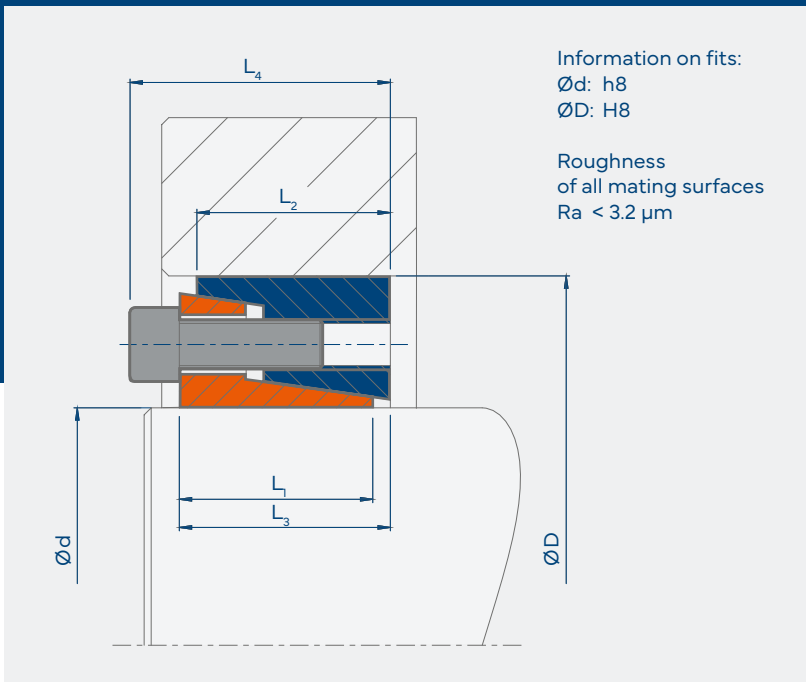

Code

- M_t Maximum transmissible torque of a locking unit for $P_{ax} = 0$
- P_{ax} Maximum transmissible axial load of a locking unit for $M_t = 0$
- M_a Required tightening torque of the locking bolts
- P_w Surface pressure between locking unit and shaft
- P_n Surface pressure between locking unit and hub

Dimensions L_3 and L_4 apply to untightened units.

Internal locking unit Type IS – Series IS 1

Type	d	x	D	M_t kNm	P_{ax} kN	L_1 mm	L_2 mm	L_3 mm	L_4 mm	B* Grade 12.9	M_a Nm	P_w N/mm ²	P_n	kg
IS1	20	x	47	0.3	34	20	17	23	29	5 x M6	17	242	121	0.2
IS1	22	x	47	0.4	34	20	17	23	29	5 x M6	17	220	121	0.2
IS1	24	x	50	0.4	34	20	17	23	29	5 x M6	17	202	114	0.2
IS1	25	x	50	0.4	34	20	17	23	29	5 x M6	17	194	114	0.2
IS1	28	x	55	0.6	43	20	17	23	29	6 x M6	17	208	124	0.3
IS1	30	x	55	0.6	43	20	17	23	29	6 x M6	17	194	124	0.3
IS1	35	x	60	0.9	51	20	17	23	29	7 x M6	17	194	133	0.3
IS1	40	x	65	1.0	51	20	17	23	29	8 x M6	17	194	140	0.3
IS1	45	x	75	1.8	80	24	20	28	36	6 x M8	41	198	142	0.6
IS1	50	x	80	2.3	92	24	20	28	36	7 x M8	41	208	156	0.6
IS1	55	x	85	2.9	105	24	20	28	36	8 x M8	41	216	167	0.7
IS1	60	x	90	3.2	107	24	20	28	36	8 x M8	41	198	158	0.7
IS1	65	x	95	3.8	117	24	20	28	36	9 x M8	41	205	169	0.8
IS1	70	x	110	6.0	171	29	24	35	45	8 x M10	83	223	172	1.3
IS1	75	x	115	6.4	171	29	24	35	45	8 x M10	83	208	164	1.4
IS1	80	x	120	6.8	170	29	24	35	45	8 x M10	83	195	157	1.5
IS1	85	x	125	8.1	191	29	24	35	45	9 x M10	83	207	170	1.6
IS1	90	x	130	9.6	213	29	24	35	45	10 x M10	83	217	181	1.7
IS1	95	x	135	10.1	213	29	24	35	45	10 x M10	83	206	175	1.7
IS1	100	x	145	11.2	224	33	28	38	50	8 x M12	145	200	163	2.3
IS1	110	x	155	13.9	252	33	28	39	51	9 x M12	145	205	171	2.5

*Locking bolts DIN EN ISO 4762: Grade 12.9

When ordering please state: (Type x $\varnothing d$ x $\varnothing D$) e.g. IS 1100 x 145

Internal locking unit Type IS – Series IS 1

Type	d	x	D	M _t kNm	P _{ax} kN	L ₁ mm	L ₂ mm	L ₃ mm	L ₄ mm	B* Grade 12.9	M _a Nm	P _w N/mm ²	P _n	kg
IS1	120	x	165	16.8	280	33	28	39	51	10 x M12	145	209	179	2.8
IS1	130	x	180	23.1	355	38	33	43	55	12 x M12	145	201	167	4.0
IS1	140	x	190	23.5	336	38	33	43	55	12 x M12	145	186	158	4.1
IS1	150	x	200	30.4	406	38	33	43	55	14 x M12	145	203	175	4.2
IS1	160	x	210	34.8	435	38	33	43	55	15 x M12	145	204	179	4.5
IS1	170	x	225	41.5	488	43	38	49	63	12 x M14	230	186	159	6.0
IS1	180	x	235	51.2	569	43	38	50	64	14 x M14	230	205	178	6.3
IS1	190	x	250	61.1	643	51	46	58	72	16 x M14	230	187	158	8.5
IS1	200	x	260	71.6	716	51	46	57	71	18 x M14	230	200	171	9.3
IS1	220	x	285	99.5	905	55	50	62	78	16 x M16	355	207	175	12
IS1	240	x	305	108.0	900	55	50	62	78	16 x M16	355	189	164	13
IS1	260	x	325	129.5	996	55	50	62	78	18 x M16	355	197	173	15
IS1	280	x	355	169.7	1212	65	60	73	91	18 x M18	485	188	161	20
IS1	300	x	375	199.8	1332	65	60	73	91	20 x M18	485	195	169	22
IS1	320	x	405	274.5	1716	77	72	86	106	18 x M20	690	198	167	31
IS1	340	x	425	289.8	1705	77	72	88	108	20 x M20	690	187	160	33
IS1	360	x	455	384.7	2137	89	84	100	122	20 x M22	930	190	159	44
IS1	380	x	475	430.0	2263	89	84	99	121	21 x M22	930	189	160	46
IS1	400	x	495	449.7	2249	89	84	99	121	21 x M22	930	180	154	48
IS1	420	x	515	545.5	2597	89	84	100	122	24 x M22	930	196	169	51
IS1	440	x	545	659.9	3000	101	96	114	138	24 x M24	1200	190	161	66
IS1	460	x	565	689.9	3000	101	96	113	137	24 x M24	1200	182	156	69
IS1	480	x	585	719.9	3000	101	96	114	138	24 x M24	1200	174	150	71
IS1	500	x	605	880.4	3522	101	96	113	137	28 x M24	1200	195	170	75

Further sizes on request, subject to technical changes.

*Locking bolts DIN EN ISO 4762: Grade 12.9

When ordering please state: (Type x Ød x ØD) e.g. IS 1 200 x 260

Internal locking unit Type IS Series ISN 1

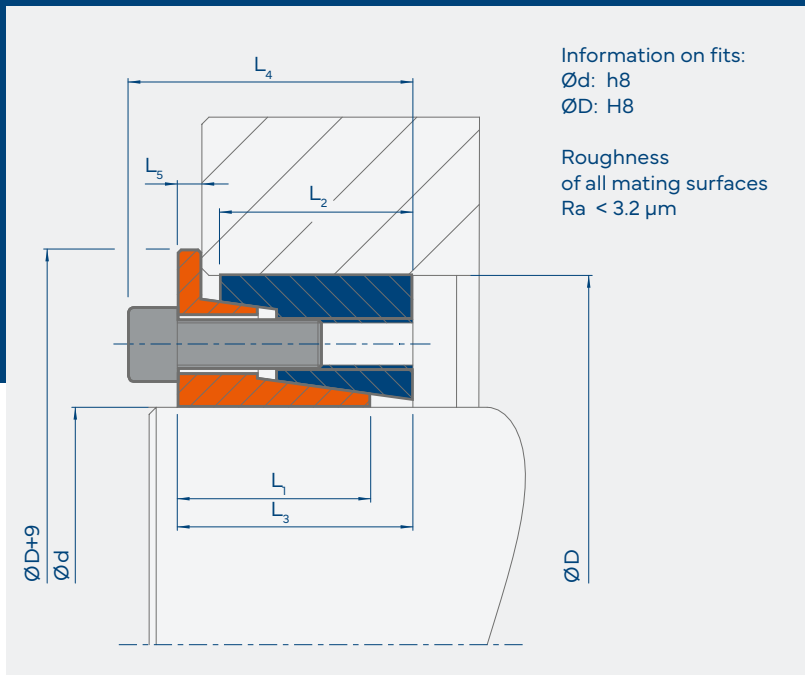

Code

- M_t Maximum transmissible torque of a locking unit for $P_{ax} = 0$
- P_{ax} Maximum transmissible axial load of a locking unit for $M_t = 0$
- M_a Required tightening torque of the locking bolts
- P_w Surface pressure between locking unit and shaft
- P_n Surface pressure between locking unit and hub

Dimensions L_3 and L_4 apply to untightened units.

Internal locking unit Type IS – Series ISN 1

Type	d	x	D	M_t kNm	P_{ax} kN	L_1 mm	L_2 mm	L_3 mm	L_4 mm	L_5 mm	B* Grade 12.9	M_a Nm	P_w N/mm ²	P_n N/mm ²	kg
ISN 1	20	x	47	0.3	28	20	17	23	29	3	6 x M6	17	185	93	0.2
ISN 1	22	x	47	0.3	28	20	17	23	29	3	6 x M6	17	168	93	0.2
ISN 1	24	x	50	0.3	28	20	17	23	29	3	6 x M6	17	154	87	0.3
ISN 1	25	x	50	0.3	28	20	17	23	29	3	6 x M6	17	148	87	0.3
ISN 1	28	x	55	0.5	37	20	17	23	29	3	8 x M6	17	176	105	0.3
ISN 1	30	x	55	0.6	37	20	17	23	29	3	8 x M6	17	164	105	0.3
ISN 1	35	x	60	0.7	42	20	17	23	29	3	9 x M6	17	158	109	0.3
ISN 1	40	x	65	0.9	46	20	17	23	29	3	10 x M6	17	154	112	0.4
ISN 1	45	x	75	1.6	69	24	20	28	36	4	8 x M8	41	168	121	0.6
ISN 1	50	x	80	2.0	80	24	20	28	36	4	9 x M8	41	170	127	0.7
ISN 1	55	x	85	2.4	87	24	20	28	36	4	10 x M8	41	171	133	0.7
ISN 1	60	x	90	2.6	87	24	20	28	36	4	10 x M8	41	157	126	0.8
ISN 1	65	x	95	3.4	105	24	20	28	36	4	12 x M8	41	174	143	0.8
ISN 1	70	x	110	4.8	137	29	24	35	45	5	10 x M10	83	177	136	1.4
ISN 1	75	x	115	5.1	137	29	24	35	45	5	10 x M10	83	166	130	1.4
ISN 1	80	x	120	6.1	151	29	24	34	44	5	10 x M10	83	171	138	1.5
ISN 1	85	x	125	7.0	165	29	24	35	45	5	12 x M10	83	175	144	1.7
ISN 1	90	x	130	7.4	165	29	24	34	44	5	12 x M10	83	166	138	1.8
ISN 1	95	x	135	8.0	163	29	24	35	45	5	12 x M10	83	157	133	1.9
ISN 1	100	x	145	10	196	33	28	39	51	5	11 x M12	145	175	142	2.5
ISN 1	110	x	155	11	196	33	28	39	51	5	11 x M12	145	159	133	2.7

*Locking bolts DIN EN ISO 4762: Grade 12.9

When ordering please state: (Type x Ød x ØD) e.g. ISN 1 110 x 155

Internal locking unit Type IS – Series ISN 1

Type	d	x	D	M _t kNm	P _{ax} kN	L ₁ mm	L ₂ mm	L ₃ mm	L ₄ mm	L ₅ mm	B* Grade 12.9	M _a Nm	P _w N/mm ²	P _n	kg
ISN 1	120	x	165	16	264	33	28	39	51	5	12 x M12	145	186	159	2.9
ISN 1	130	x	180	20	301	38	33	43	55	5	16 x M12	145	170	142	3.9
ISN 1	140	x	190	21	301	38	33	43	55	5	16 x M12	145	158	134	4.2
ISN 1	150	x	200	25	332	38	33	43	55	5	18 x M12	145	166	143	4.4
ISN 1	160	x	210	27	339	38	33	43	55	5	18 x M12	145	156	137	4.7
ISN 1	170	x	225	35	414	44	38	50	64	6	16 x M14	230	158	135	6.0
ISN 1	180	x	235	42	465	44	38	50	64	6	18 x M14	230	168	145	6.6
ISN 1	190	x	250	51	537	52	46	58	72	6	21 x M14	230	156	132	9.0
ISN 1	200	x	260	62	620	52	46	58	72	6	24 x M14	230	170	145	9.1
ISN 1	220	x	285	79	719	57	50	64	80	7	21 x M16	355	164	139	12
ISN 1	240	x	305	92	763	57	50	64	80	7	21 x M16	355	158	137	13
ISN 1	260	x	325	112	863	57	50	64	80	7	24 x M16	355	167	147	14
ISN 1	280	x	355	145	1039	70	60	78	96	10	24 x M18	485	159	136	21
ISN 1	300	x	375	175	1168	72	60	80	91	12	24 x M18	485	167	145	23
ISN 1	320	x	405	242	1510	87	72	95	105	15	24 x M20	690	170	144	32
ISN 1	340	x	425	257	1510	87	72	96	106	15	24 x M20	690	160	137	35
ISN 1	360	x	455	338	1879	99	84	110	122	15	24 x M22	930	156	130	47
ISN 1	380	x	475	357	1879	99	84	110	122	15	24 x M22	930	147	125	46
ISN 1	400	x	495	438	2192	99	84	110	122	15	28 x M22	930	163	140	48
ISN 1	420	x	515	493	2349	99	84	110	122	15	30 x M22	930	167	144	51
ISN 1	440	x	545	566	2573	111	96	123	137	15	30 x M24	1200	161	137	67
ISN 1	460	x	565	592	2573	111	96	123	137	15	33 x M24	1200	154	132	70
ISN 1	480	x	585	617	2571	111	96	123	137	15	33 x M24	1200	148	128	73
ISN 1	500	x	605	723	2892	111	96	123	137	15	36 x M24	1200	160	139	80

Further sizes on request, subject to technical changes.

*Locking bolts DIN EN ISO 4762: Grade 12.9

When ordering please state: (Type x Ød x ØD) e.g. ISN 1 200 x 260

Internal locking unit Type IS Series IS 2

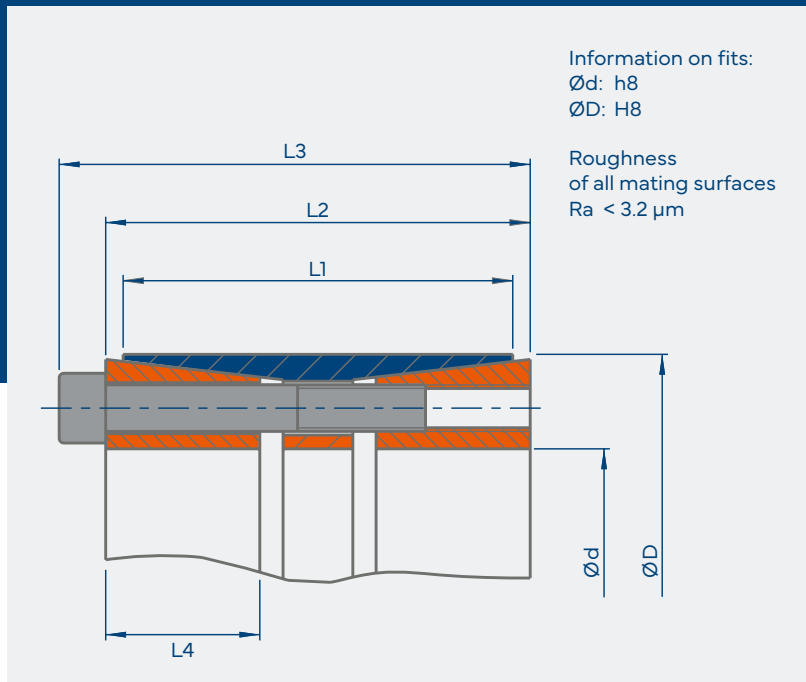

Code

- M_t Maximum transmissible torque of a locking unit for $P_{ax} = 0$
- P_{ax} Maximum transmissible axial load of a locking unit for $M_t = 0$
- M_a Required tightening torque of the locking bolts
- P_w Surface pressure between locking unit and shaft
- P_n Surface pressure between locking unit and hub

Dimensions L_2 and L_3 apply to untightened units.

Internal locking unit Type IS – Series IS 2

Type	d x D	M_t kNm	P_{ax} kN	L_1 mm	L_2 mm	L_3 mm	L_4 mm	B* Grade 12.9	M_a Nm	P_w N/mm ²	P_n	kg
IS 2	70 x 110	7.3	208	50	60	70	21	8 x M10	83	187	100	2.2
IS 2	80 x 120	10.6	264	50	60	70	21	9 x M10	83	209	117	2.5
IS 2	85 x 125	11.0	260	50	60	70	21	10 x M10	83	193	110	2.6
IS 2	90 x 130	11.7	260	50	60	70	21	10 x M10	83	182	106	2.7
IS 2	95 x 135	12.3	260	50	60	70	21	10 x M10	83	173	102	2.8
IS 2	100 x 145	19.0	379	60	70	82	25	10 x M12	145	201	116	4.1
IS 2	110 x 155	20.9	379	60	70	82	25	10 x M12	145	183	108	4.4
IS 2	120 x 165	25.0	417	60	70	82	25	11 x M12	145	184	112	4.7
IS 2	130 x 180	29.6	455	65	79	91	27	12 x M12	145	172	103	6.2
IS 2	140 x 190	36.0	514	65	79	91	27	12 x M12	145	180	110	6.6
IS 2	150 x 200	39.8	531	65	79	91	27	14 x M12	145	174	108	7.0
IS 2	160 x 210	42.5	531	65	79	91	27	14 x M12	145	163	103	7.4
IS 2	170 x 225	61.6	725	78	92	106	32	14 x M14	230	177	110	10.4
IS 2	180 x 235	65.2	725	78	92	106	32	14 x M14	230	167	105	10.9
IS 2	190 x 250	78.7	828	88	102	116	36	16 x M14	230	161	100	14.3
IS 2	200 x 260	93.7	937	88	102	116	36	16 x M14	230	173	109	14.9
IS 2	220 x 285	118.3	1075	96	108	124	40	15 x M16	355	162	104	19.4
IS 2	240 x 305	137.6	1147	96	108	124	40	16 x M16	355	158	104	20.9
IS 2	260 x 325	167.7	1290	96	108	124	40	18 x M16	355	165	110	22.4
IS 2	280 x 355	219.6	1569	96	110	130	40	14 x M20	690	186	122	28.1
IS 2	300 x 375	252.1	1681	96	110	130	40	15 x M20	690	186	124	29.8

Further sizes on request, subject to technical changes.

*Locking bolts to DIN EN ISO 4762; grade 12.9

When ordering please state: (Type x Ød x ØD) e.g. IS 2 x 500 x 595

Internal locking unit Type IS – Series IS 2

Type	d x D	M _t kNm	P _{ax} kN	L ₁ mm	L ₂ mm	L ₃ mm	L ₄ mm	B* Grade 12.9	M _a Nm	P _w N/mm ²	P _n	kg
IS 2	320 x 405	322.7	2017	124	136	156	52	18 x M20	690	161	107	46.9
IS 2	340 x 425	361.9	2129	124	136	156	52	19 x M20	690	160	107	49.5
IS 2	360 x 455	453.0	2517	140	155	177	58	18 x M22	930	160	105	66.7
IS 2	380 x 475	504.8	2657	140	155	177	58	19 x M22	930	160	106	69.8
IS 2	400 x 495	559.3	2797	140	155	177	58	20 x M22	930	160	107	73.1
IS 2	420 x 515	616.6	2936	140	155	177	58	21 x M22	930	160	108	76.4
IS 2	440 x 535	676.8	3076	140	155	177	58	22 x M22	930	160	109	79.6
IS 2	460 x 555	739.7	3216	140	155	177	58	23 x M22	930	160	110	82.9
IS 2	480 x 575	805.4	3356	140	155	177	58	24 x M22	930	160	111	86.2
IS 2	500 x 595	873.9	3496	140	155	177	58	25 x M22	930	160	111	89.4
IS 2	520 x 615	945.2	3636	140	155	177	58	26 x M22	930	160	112	92.7
IS 2	540 x 635	1019.4	3775	140	155	177	58	27 x M22	930	160	113	96.0
IS 2	560 x 655	1096.3	3915	140	155	177	58	28 x M22	930	160	113	99.2
IS 2	580 x 675	1176.0	4055	140	155	177	58	29 x M22	930	160	114	102.5
IS 2	600 x 695	1258.5	4195	140	155	177	58	30 x M22	930	160	114	105.8

Further sizes on request, subject to technical changes.

*Locking bolts to DIN EN ISO 4762; grade 12.9

When ordering please state: (Type x Ød x ØD) e.g. IS 2 x 500 x 595

Internal locking unit Type IS Series IS 3

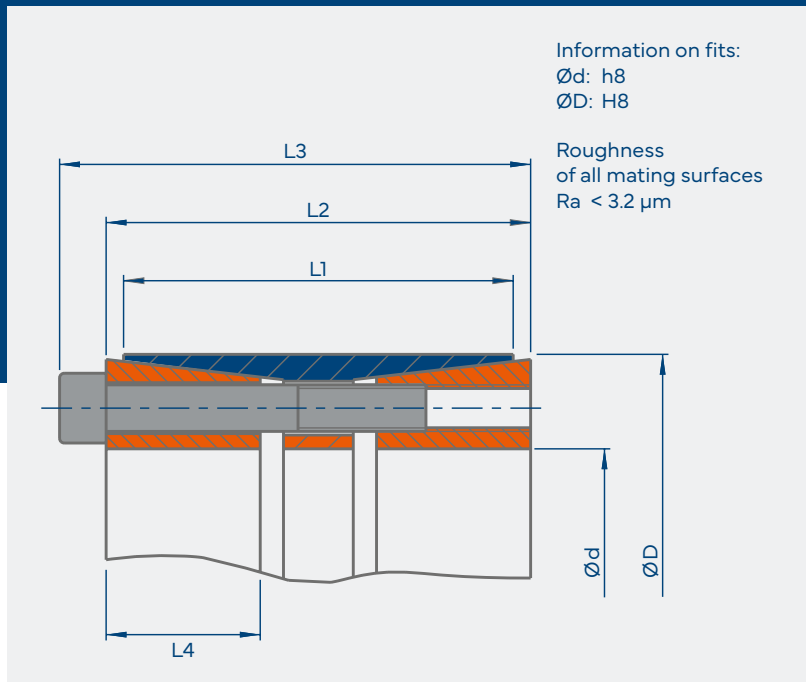

Code

- M_t Maximum transmissible torque of a locking unit for $P_{ax} = 0$
- P_{ax} Maximum transmissible axial load of a locking unit for $M_t = 0$
- M_a Required tightening torque of the locking bolts
- P_w Surface pressure between locking unit and shaft
- P_n Surface pressure between locking unit and hub

Dimensions L_2 and L_3 apply to untightened units.

Internal locking unit Type IS – Series IS 3

Type	d x D	M_t kNm	P_{ax} kN	L_1 mm	L_2 mm	L_3 mm	L_4 mm	B* Grade 12.9	M_a Nm	P_w N/mm ²	P_n	kg
IS 3	45 x 75	3.1	139	56	64	72	23	7 x M8	41	179	88	1.2
IS 3	50 x 80	3.9	155	56	64	72	23	8 x M8	41	179	92	1.3
IS 3	55 x 85	4.8	175	56	64	72	23	9 x M8	41	183	97	1.4
IS 3	60 x 90	5.8	194	56	64	72	23	9 x M8	41	187	102	1.5
IS 3	65 x 95	6.3	194	56	65	72	23	9 x M8	41	173	97	1.7
IS 3	70 x 110	10.8	309	70	78	88	30	9 x M10	83	195	107	3.1
IS 3	75 x 115	10.4	278	70	78	88	30	9 x M10	83	164	92	3.3
IS 3	80 x 120	12.4	309	70	78	88	30	10 x M10	83	171	98	3.4
IS 3	85 x 125	13.1	309	70	78	88	30	10 x M10	83	161	94	3.6
IS 3	90 x 130	15.3	340	70	82	92	30	11 x M10	83	167	99	3.8
IS 3	95 x 135	16.1	340	70	82	92	30	12 x M10	83	158	95	4.0
IS 3	100 x 145	22.5	451	90	100	112	36	10 x M12	145	166	92	6.1
IS 3	110 x 155	27.3	496	90	100	112	36	11 x M12	145	166	94	6.6
IS 3	120 x 165	32.4	541	90	100	112	36	12 x M12	145	166	97	7.1
IS 3	130 x 180	44.0	677	104	116	130	43	12 x M14	230	164	96	9.9
IS 3	140 x 190	54.5	778	104	116	130	42	12 x M14	230	176	104	10.5
IS 3	150 x 200	55.4	739	104	116	130	42	12 x M14	230	155	94	11.2
IS 3	160 x 210	67.5	843	104	116	130	42	13 x M14	230	166	102	11.8
IS 3	170 x 225	91.6	1077	134	146	162	53	12 x M16	355	159	95	17.9
IS 3	180 x 235	100.7	1119	134	146	162	55	13 x M16	355	156	94	18.8
IS 3	190 x 250	113.3	1193	134	146	162	55	14 x M16	355	157	94	21.7

Further sizes on request, subject to technical changes.

*Locking bolts to DIN EN ISO 4762; grade 12.9

When ordering please state: (Type x Ød x ØD) e.g. IS 3 x 500 x 595

Internal locking unit Type IS – Series IS 3

Type	d x D	M _t kNm	P _{ax} kN	L ₁ mm	L ₂ mm	L ₃ mm	L ₄ mm	B* Grade 12.9	M _a Nm	P _w N/mm ²	P _n	kg
IS 3	200 x 260	119.3	1193	134	150	166	55	14 x M16	355	149	91	22.7
IS 3	220 x 285	149.9	1363	134	146	162	53	16 x M16	355	155	95	27.0
IS 3	240 x 305	173.8	1448	134	146	162	55	18 x M16	355	151	94	29.2
IS 3	260 x 325	199.3	1533	134	146	162	53	18 x M16	355	148	93	31.3
IS 3	280 x 355	298.3	2131	165	177	197	69	16 x M20	690	146	96	48.3
IS 3	300 x 375	339.6	2264	165	177	197	69	17 x M20	690	145	97	51.3
IS 3	32 x 405	383.6	2397	165	177	197	69	18 x M20	690	144	95	62.5
IS 3	340 x 425	430.2	2530	165	177	197	69	19 x M20	690	143	96	65.9
IS 3	360 x 455	538.5	2992	190	206	228	82	18 x M22	930	157	92	90.4
IS 3	380 x 475	585.0	3079	190	206	228	82	19 x M22	930	154	91	94.8
IS 3	400 x 495	648.3	3241	190	206	228	82	20 x M22	930	154	91	99.2
IS 3	420 x 515	714.7	3403	190	206	228	82	21 x M22	930	154	92	103.7
IS 3	440 x 535	784.4	3565	190	206	228	83	24 x M22	930	154	93	108.1
IS 3	460 x 555	857.3	3727	190	206	228	83	24 x M22	930	154	94	112.5
IS 3	480 x 575	933.5	3890	190	206	228	83	24 x M22	930	154	94	117.0
IS 3	500 x 595	1012.9	4052	190	206	228	83	25 x M22	930	154	95	121.4
IS 3	520 x 615	1095.5	4214	190	206	228	83	26 x M22	930	154	96	125.8
IS 3	540 x 635	1211.7	4488	190	206	228	83	28 x M22	930	157	99	130.3
IS 3	560 x 655	1270.6	4538	190	206	228	83	28 x M22	930	154	97	134.7
IS 3	580 x 675	1363.0	4700	190	206	228	83	29 x M22	930	154	97	139.1
IS 3	600 x 695	1458.6	4862	190	206	228	83	30 x M22	930	154	98	143.6

Further sizes on request, subject to technical changes.

*Locking bolts to DIN EN ISO 4762; grade 12.9

When ordering please state: (Type x Ød x ØD) e.g. IS 3 x 500 x 595

Internal locking unit Type IS Series IS 4

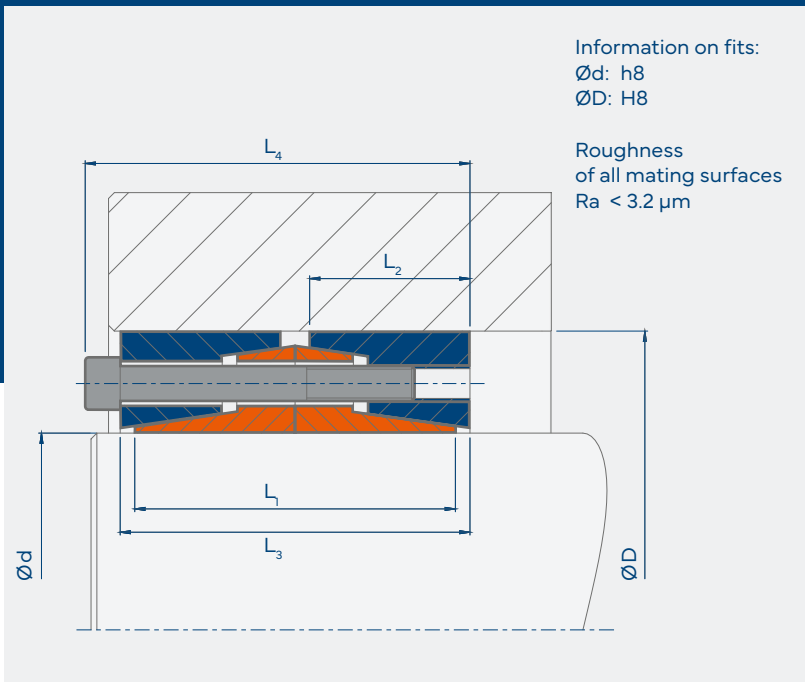

Code

- M_t Maximum transmissible torque of a locking unit for $P_{ax} = 0$
- P_{ax} Maximum transmissible axial load of a locking unit for $M_t = 0$
- M_a Required tightening torque of the locking bolts
- P_w Surface pressure between locking unit and shaft
- P_n Surface pressure between locking unit and hub

Dimensions L_3 and L_4 apply to untightened units.

Internal locking unit Type IS – Series IS 4

Type	d	x	D	M_t kNm	P_{ax} kN	L_1 mm	L_2 mm	L_3 mm	L_4 mm	B* Grade 12.9	M_a Nm	P_w N/mm ²	P_n	kg
IS 4	30	x	55	0.9	60	40	17	46	52	6 x M6	17	132	85	0.5
IS 4	35	x	60	1.2	71	40	17	46	52	7 x M6	17	135	93	0.6
IS 4	40	x	65	1.5	75	40	17	46	52	8 x M6	17	125	90	0.6
IS 4	45	x	75	2.5	111	48	20	56	64	6 x M8	41	136	98	1.1
IS 4	50	x	80	3.0	120	48	20	56	64	7 x M8	41	133	100	1.1
IS 4	55	x	85	3.8	138	48	20	56	64	8 x M8	41	139	108	1.2
IS 4	60	x	90	4.3	143	48	20	56	64	8 x M8	41	132	106	1.3
IS 4	65	x	95	5.3	163	48	20	56	64	9 x M8	41	139	114	1.4
IS 4	70	x	110	7.6	217	58	24	70	80	8 x M10	83	142	109	2.6
IS 4	75	x	115	8.2	219	58	24	70	80	8 x M10	83	133	105	2.7
IS 4	80	x	120	8.7	217	58	24	70	80	8 x M10	83	124	100	2.8
IS 4	85	x	125	10.4	245	58	24	70	80	9 x M10	83	132	108	3.0
IS 4	90	x	130	12	272	58	24	70	80	10 x M10	83	138	116	3.1
IS 4	95	x	135	13	271	58	24	70	80	10 x M10	83	131	111	3.3
IS 4	100	x	145	16	317	66	28	76	88	8 x M12	145	127	104	4.5
IS 4	110	x	155	19	340	66	28	78	90	9 x M12	145	124	104	4.8
IS 4	120	x	165	23	377	66	28	78	90	10 x M12	145	126	108	5.2
IS 4	130	x	180	29	453	76	33	86	98	12 x M12	145	122	101	7.2
IS 4	140	x	190	32	453	76	33	86	98	12 x M12	145	113	96	7.7
IS 4	150	x	200	40	528	76	33	86	98	14 x M12	145	123	106	8.2
IS 4	160	x	210	45	566	76	33	86	98	15 x M12	145	123	108	8.6

*Locking bolts DIN EN ISO 4762: Grade 12.9

When ordering please state: (Type x $\text{Ø}d$ x $\text{Ø}D$) e.g. IS 4 x 100 x 145

Internal locking unit Type IS – Series IS 4

Type	d	x	D	M _t kNm	P _{ax} kN	L ₁ mm	L ₂ mm	L ₃ mm	L ₄ mm	B* Grade 12.9	M _a Nm	P _w N/mm ²	P _n	kg
IS 4	170	x	225	53	622	86	38	98	112	12 x M14	230	113	96	11
IS 4	180	x	235	65	726	86	38	98	112	14 x M14	230	124	108	12
IS 4	190	x	250	79	829	102	46	114	128	16 x M14	230	114	96	17
IS 4	200	x	260	93	933	102	46	114	128	18 x M14	230	121	103	17
IS 4	220	x	285	126	1141	110	50	124	140	16 x M16	355	125	106	22
IS 4	240	x	305	137	1141	110	50	124	140	16 x M16	355	115	99	24
IS 4	260	x	325	167	1284	110	50	124	140	18 x M16	355	119	106	26
IS 4	280	x	355	219	1562	130	60	146	164	18 x M18	485	114	97	38
IS 4	300	x	375	260	1735	130	60	146	164	18 x M18	485	118	102	40
IS 4	320	x	405	357	2230	154	72	172	192	18 x M20	690	120	101	58
IS 4	340	x	425	379	2230	154	72	176	196	20 x M20	690	113	97	62
IS 4	360	x	455	501	2784	178	84	200	222	18 x M22	930	115	97	85
IS 4	380	x	475	555	2923	178	84	198	220	20 x M22	930	115	97	89
IS 4	400	x	495	585	2923	178	84	198	220	20 x M22	930	109	93	93
IS 4	420	x	515	658	3132	178	84	200	222	22 x M22	930	111	96	97
IS 4	440	x	545	796	3616	202	96	220	244	22 x M24	1200	108	92	128
IS 4	460	x	565	832	3616	202	96	226	250	22 x M24	1200	103	88	134
IS 4	480	x	585	868	3616	202	96	228	252	24 x M24	1200	99	85	139
IS 4	500	x	605	984	3938	202	96	226	250	26 x M24	1200	103	90	144
IS 4	520	x	630	1024	3938	202	96	226	250	25 x M24	1200	99	86	157
IS 4	540	x	650	1063	3938	202	96	226	250	26 x M24	1200	96	84	162
IS 4	560	x	670	1181	4219	202	96	226	250	27 x M24	1200	99	87	168
IS 4	580	x	690	1224	4219	202	96	226	250	27 x M24	1200	96	84	173
IS 4	600	x	710	1266	4219	202	96	226	250	27 x M24	1200	92	82	179

Further sizes on request, subject to technical changes.

*Locking bolts DIN EN ISO 4762: Grade 12.9

When ordering please state: (Type x Ød x ØD) e.g. IS 4 200 x 260

Internal locking unit Type IS Series IS 4.1

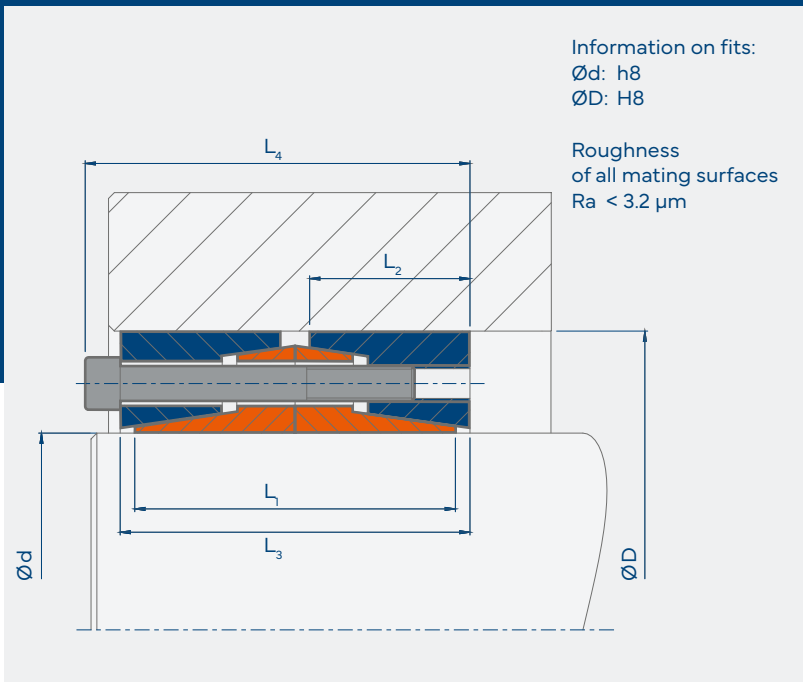

Information on fits:
Ød: h8
ØD: H8

Roughness
of all mating surfaces
 $R_a < 3.2 \mu\text{m}$

Code

- M_t Maximum transmissible torque of a locking unit for $P_{ax} = 0$
- P_{ax} Maximum transmissible axial load of a locking unit for $M_t = 0$
- M_a Required tightening torque of the locking bolts
- P_w Surface pressure between locking unit and shaft
- P_n Surface pressure between locking unit and hub

Dimensions L_3 and L_4 apply to untightened units.

Internal locking unit Type IS – Series IS 4.1

Type	d	x	D	M_t kNm	P_{ax} kN	L_1 mm	L_2 mm	L_3 mm	L_4 mm	B* Grade 12.9	M_a Nm	P_w N/mm ²	P_n	kg
IS 4.1	100	x	145	11	224	66	28	76	86	8 x M10	83	90	73	4
IS 4.1	110	x	155	13	240	66	28	78	88	9 x M10	83	88	73	5
IS 4.1	120	x	165	16	267	66	28	78	88	10 x M10	83	89	77	5
IS 4.1	130	x	180	20	312	76	33	86	96	12 x M10	83	84	70	7
IS 4.1	140	x	190	22	320	76	33	86	96	12 x M10	83	80	68	8
IS 4.1	150	x	200	27	364	76	33	86	96	14 x M10	83	85	73	8
IS 4.1	160	x	210	31	390	76	33	86	96	15 x M10	83	85	75	9
IS 4.1	170	x	225	38	449	86	38	98	110	12 x M12	145	82	70	11
IS 4.1	180	x	235	47	524	86	38	98	110	14 x M12	145	90	78	12
IS 4.1	190	x	250	57	599	102	46	114	126	16 x M12	145	82	69	17
IS 4.1	200	x	260	67	674	102	46	114	126	18 x M12	145	88	75	17
IS 4.1	220	x	285	91	828	110	50	124	138	16 x M14	230	91	77	22
IS 4.1	240	x	305	99	822	110	50	124	138	16 x M14	230	83	72	24
IS 4.1	260	x	325	122	937	110	50	124	138	18 x M14	230	87	76	26
IS 4.1	280	x	355	181	1294	130	60	146	162	18 x M16	355	94	81	38
IS 4.1	300	x	375	215	1431	130	60	146	162	20 x M16	355	97	84	40
IS 4.1	320	x	405	276	1725	154	72	172	190	18 x M18	485	93	78	58
IS 4.1	340	x	425	294	1732	154	72	176	194	20 x M18	485	88	75	62
IS 4.1	360	x	455	372	2065	178	84	200	218	22 x M18	485	85	72	85
IS 4.1	380	x	475	393	2068	178	84	198	216	22 x M18	485	81	69	89
IS 4.1	400	x	495	414	2068	178	84	198	216	24 x M18	485	77	66	93

*Locking bolts DIN EN ISO 4762: Grade 12.9

When ordering please state: (Type x Ød x ØD) e.g. IS 4.1 170 x 225

Internal locking unit Type IS – Series IS 4.1

Type	d	x	D	M _t kNm	P _{ax} kN	L ₁ mm	L ₂ mm	L ₃ mm	L ₄ mm	B* Grade 12.9	M _a Nm	P _w N/mm ²	P _n	kg
IS 4.1	420	x	515	507	2412	178	84	200	218	26 x M18	485	86	74	97
IS 4.1	440	x	545	530	2409	202	96	228	248	24 x M20	690	72	61	128
IS 4.1	460	x	565	554	2409	202	96	226	246	22 x M20	690	69	59	134
IS 4.1	480	x	585	578	2409	202	96	228	248	24 x M20	690	66	57	139
IS 4.1	500	x	605	703	2811	202	96	226	246	26 x M20	690	74	64	144
IS 4.1	520	x	630	731	2811	202	96	226	246	26 x M20	690	71	62	157
IS 4.1	540	x	650	759	2811	202	96	226	246	26 x M20	690	68	60	162
IS 4.1	560	x	670	843	3012	202	96	226	246	30 x M20	690	71	62	168
IS 4.1	580	x	690	873	3012	202	96	226	246	30 x M20	690	68	60	173
IS 4.1	600	x	710	903	3012	202	96	226	246	30 x M20	690	66	59	179

Further sizes on request, subject to technical changes.

*Locking bolts DIN EN ISO 4762: Grade 12.9

When ordering please state: (Type x Ød x ØD) e.g. IS 4.1 420 x 515

You have not found what you are looking for in our comprehensive range of standard-products?
We will be happy to promptly prepare any form of custom-made product and development innovation
even using special materials such as 1.3974. Please feel free to contact us.

Internal locking unit TYPE IS

Special Solutions

Individual locking unit

Four-part internal locking unit for small installation spaces

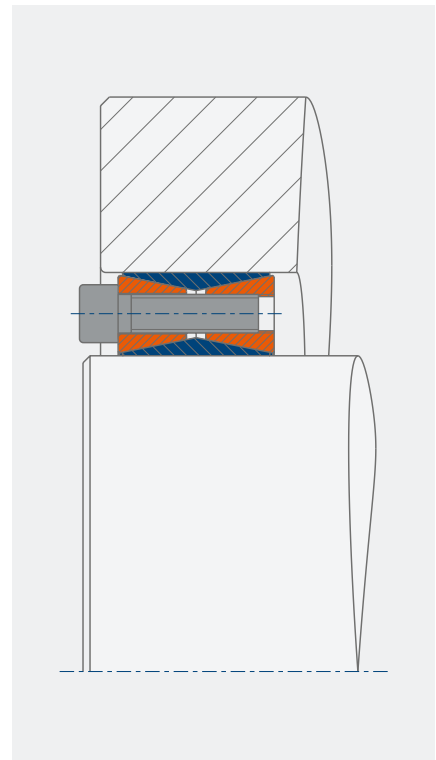
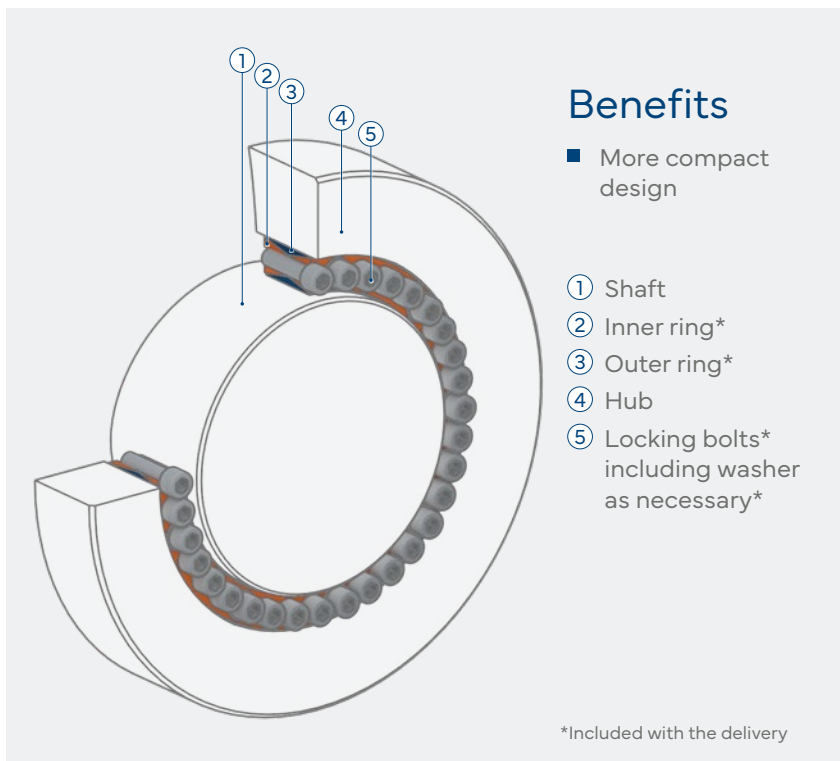

STÜWE[®]



Services



High Performance

In addition to our standard supply range, we offer a comprehensive selection of special solutions. We use modern design methods to ensure the consistent ongoing development of our product range and build customized special solutions based on your requirements.

Whether dealing with new systems or the integration of a locking element into a previously existing system, both our specialist engineers and our industrial representatives will be ready to assist you at any time with your wishes, suggestions and adjustments. We will be happy to work together with you on individual challenges regarding material, painting, coating or also special lubrication with the aid of our extensive expertise.

Material

In addition to the standard use of heat-treated steel, we are also capable of designing and manufacturing frictional connections out of special materials such as 1.4501 and many other alloys.

Painting and Coating

Thanks to our own in-house paint shop, we are capable of achieving a broad range of paint and coating options for you. All shrink discs may be painted using paints from the RAL colour spectrum and, if desired, with an appropriate corrosion protection class in accordance with DIN EN ISO 12944. In order to ensure the corrosion protection of the frictional connections, all shrink discs may also be provided with coatings such as nickel or zinc. Further coating processes are possible after consultation.

Lubrication

In order to generate optimum coefficients of friction, the lubricants used on our components are based as standard on mineral oils. As an alternative to the standard we offer a modification using NSF H1 classified lubricants that are permitted for use in applications where product contact may not be fully excluded, for example in the foodstuff and nutritional and pharmaceutical industries.

Product Certification

Our experienced development team applies its technical and business standards in a skilled and efficient manner while taking into account quality features and such items as the demands of certification organisations. For this purpose we collaborate closely with various certification organisations from the maritime industry and the wind power sector.

Job Order Production and Measurement Equipment

We have a comprehensive range of machinery and are capable of manufacturing rotationally symmetric components with a diameter of 20 mm - 2200 mm and a height of 1400 mm with a maximum component weight of 10t. In addition, we have an extensive range of 3D measurement equipment which enable us to directly check the dimensional accuracy of manufactured components.

STÜWE[®]

STÜWE[®] GmbH & Co. KG

Zum Ludwigstal 35 · 45527 Hattingen · Germany

Phone: +49 2324 394-41

Enquiries: sales@stuewe.de

Orders: process@stuewe.de

www.stuewe.de



For further information about our international sales agents please visit our website

STÜWE[®]

STÜWE[®] LARAON India Pvt Ltd

137, Sector 5 IMT Manesar · Gurgaon 122050 · Haryana · India

Phone: +91 9971 010600 · +91 124 4959000

info@stuewe.in

www.stuewe.in