



**STÜWE<sup>®</sup>**

**Produktkatalog**  
**Innenspannsatz TYP IS**



Zertifiziert nach  
DIN ISO 9001:2008

# STÜWE®

## INNENSPANNSATZ TYP IS



# INNENSPANNSATZ TYP IS – ALLGEMEINES

## Anwendungsbeschreibung

Mit den Innenspannsätzen lassen sich Naben aller Art auf handelsüblichen Wellen befestigen. Dabei bietet jeder Typ die folgenden Vorteile: selbstzentrierend, selbsthemmende Kegelwinkel, Erhöhung der Rundlaufgenauigkeit durch Vorzentrierung.

## Einsatzgebiete

Baureihe	Wellendurchmesser	Übertragbare Drehmomente	Einsatzgebiet
IS1	20 - 500 mm	0,3 - 880 kNm	Kleiner Einbauraum Verschieben der Nabe beim Spannen
ISN1	20 - 500 mm	0,3 - 723 kNm	Axial fixierend Kein Verschieben der Nabe beim Spannen
IS4	30 - 600 mm	0,9 - 1266 kNm	Für höchste Drehmomente Kein Verschieben der Nabe beim Spannen
IS4.1	100 - 600 mm	11 - 903 kNm	Reduzierte Flächenpressung Speziell für Förderbandtrommeln geeignet Kein Verschieben der Nabe beim Spannen

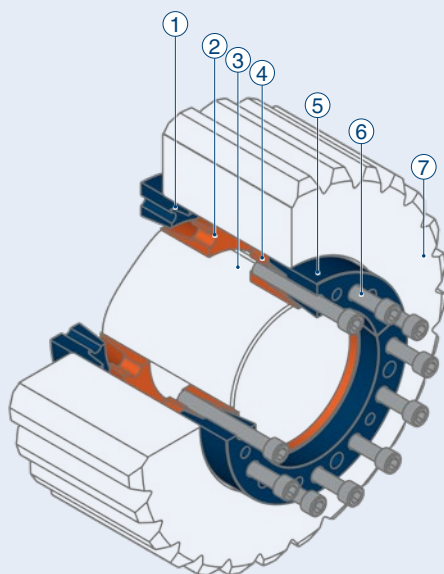

- ① Außenring 1\*
- ② Innenring 1\*
- ③ Welle
- ④ Innenring 2\*
- ⑤ Außenring 2\*
- ⑥ Spannschrauben\*
- ⑦ Nabe (bspw. Zahnrad)

\*Im Lieferumfang enthalten

# STÜWE® Innenspannsatz Typ IS – Baureihe IS 1

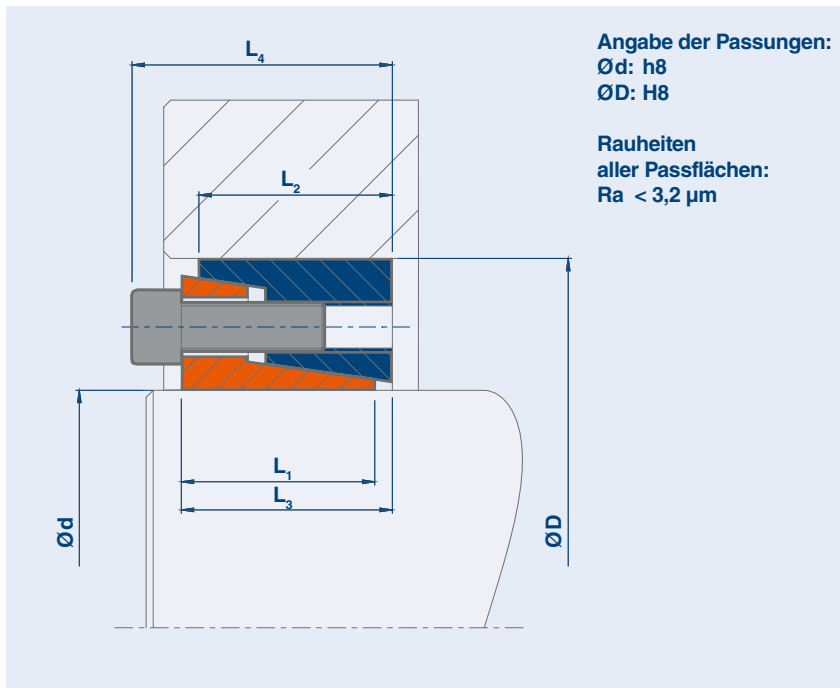

## Erläuterungen

- $M_t$  Maximal übertragbares Drehmoment eines Spannsatzes bei  $P_{ax} = 0$
- $P_{ax}$  Maximal übertragbare Axialkraft eines Spannsatzes bei  $M_t = 0$
- $M_a$  Erforderliches Anzugsmoment der Spannschrauben
- $P_w$  Flächenpressung zwischen Spannsatz und Welle
- $P_n$  Flächenpressung zwischen Spannsatz und Nabe

Die Maße  $L_3$  und  $L_4$  gelten für den ungespannten Zustand.

## Innenspannsatz Typ IS – Baureihe IS 1

Typ	d	x	D	$M_t$ kNm	$P_{ax}$ kN	$L_1$ mm	$L_2$ mm	$L_3$ mm	$L_4$ mm	B* Güte 12.9	$M_a$ Nm	$P_w$ N/mm <sup>2</sup>	$P_n$	kg
IS1	20	x	47	0,3	34	20	17	23	29	5 x M6	17	242	121	0,2
IS1	22	x	47	0,4	34	20	17	23	29	5 x M6	17	220	121	0,2
IS1	24	x	50	0,4	34	20	17	23	29	5 x M6	17	202	114	0,2
IS1	25	x	50	0,4	34	20	17	23	29	5 x M6	17	194	114	0,2
IS1	28	x	55	0,6	43	20	17	23	29	6 x M6	17	208	124	0,3
IS1	30	x	55	0,6	43	20	17	23	29	6 x M6	17	194	124	0,3
IS1	35	x	60	0,9	51	20	17	23	29	7 x M6	17	194	133	0,3
IS1	40	x	65	1,0	51	20	17	23	29	8 x M6	17	194	140	0,3
IS1	45	x	75	1,8	80	24	20	28	36	6 x M8	41	198	142	0,6
IS1	50	x	80	2,3	92	24	20	28	36	7 x M8	41	208	156	0,6
IS1	55	x	85	2,9	105	24	20	28	36	8 x M8	41	216	167	0,7
IS1	60	x	90	3,2	107	24	20	28	36	8 x M8	41	198	158	0,7
IS1	65	x	95	3,8	117	24	20	28	36	9 x M8	41	205	169	0,8
IS1	70	x	110	6,0	171	29	24	35	45	8 x M10	83	223	172	1,3
IS1	75	x	115	6,4	171	29	24	35	45	8 x M10	83	208	164	1,4
IS1	80	x	120	6,8	170	29	24	35	45	8 x M10	83	195	157	1,5
IS1	85	x	125	8,1	191	29	24	35	45	9 x M10	83	207	170	1,6
IS1	90	x	130	9,6	213	29	24	35	45	10 x M10	83	217	181	1,7
IS1	95	x	135	10,1	213	29	24	35	45	10 x M10	83	206	175	1,7
IS1	100	x	145	11,2	224	33	28	38	50	8 x M12	145	200	163	2,3
IS1	110	x	155	13,9	252	33	28	39	51	9 x M12	145	205	171	2,5

\*Spannschrauben DIN EN ISO 4762: Güte 12.9

Bestellangabe: (Typ x  $\varnothing d$  x  $\varnothing D$ ), z. B. IS 1 100 x 145

## Innenspannsatz Typ IS – Baureihe IS 1

Typ	d	x	D	M <sub>t</sub> kNm	P <sub>ax</sub> kN	L <sub>1</sub> mm	L <sub>2</sub> mm	L <sub>3</sub> mm	L <sub>4</sub> mm	B* Güte 12.9	M <sub>a</sub> Nm	P <sub>w</sub> N/mm <sup>2</sup>	P <sub>n</sub>	kg
IS1	120	x	165	16,8	280	33	28	39	51	10 x M12	145	209	179	2,8
IS1	130	x	180	23,1	355	38	33	43	55	12 x M12	145	201	167	4,0
IS1	140	x	190	23,5	336	38	33	43	55	12 x M12	145	186	158	4,1
IS1	150	x	200	30,4	406	38	33	43	55	14 x M12	145	203	175	4,2
IS1	160	x	210	34,8	435	38	33	43	55	15 x M12	145	204	179	4,5
IS1	170	x	225	41,5	488	43	38	49	63	12 x M14	230	186	159	6,0
IS1	180	x	235	51,2	569	43	38	50	64	14 x M14	230	205	178	6,3
IS1	190	x	250	61,1	643	51	46	58	72	16 x M14	230	187	158	8,5
IS1	200	x	260	71,6	716	51	46	57	71	18 x M14	230	200	171	9,3
IS1	220	x	285	99,5	905	55	50	62	78	16 x M16	355	207	175	12
IS1	240	x	305	108,0	900	55	50	62	78	16 x M16	355	189	164	13
IS1	260	x	325	129,5	996	55	50	62	78	18 x M16	355	197	173	15
IS1	280	x	355	169,7	1212	65	60	73	91	18 x M18	485	188	161	20
IS1	300	x	375	199,8	1332	65	60	73	91	20 x M18	485	195	169	22
IS1	320	x	405	274,5	1716	77	72	86	106	18 x M20	690	198	167	31
IS1	340	x	425	289,8	1705	77	72	88	108	20 x M20	690	187	160	33
IS1	360	x	455	384,7	2137	89	84	100	122	20 x M22	930	190	159	44
IS1	380	x	475	430,0	2263	89	84	99	121	21 x M22	930	189	160	46
IS1	400	x	495	449,7	2249	89	84	99	121	21 x M22	930	180	154	48
IS1	420	x	515	545,5	2597	89	84	100	122	24 x M22	930	196	169	51
IS1	440	x	545	659,9	3000	101	96	114	138	24 x M24	1200	190	161	66
IS1	460	x	565	689,9	3000	101	96	113	137	24 x M24	1200	182	156	69
IS1	480	x	585	719,9	3000	101	96	114	138	24 x M24	1200	174	150	71
IS1	500	x	605	880,4	3522	101	96	113	137	28 x M24	1200	195	170	75

Weitere Größen auf Anfrage, technische Änderungen vorbehalten

\*Spannschrauben DIN EN ISO 4762: Güte 12.9

**Bestellangabe:** (Typ x Ød x ØD), z. B. IS 1 200 x 260

# STÜWE® Innenspannsatz Typ IS – Baureihe ISN 1

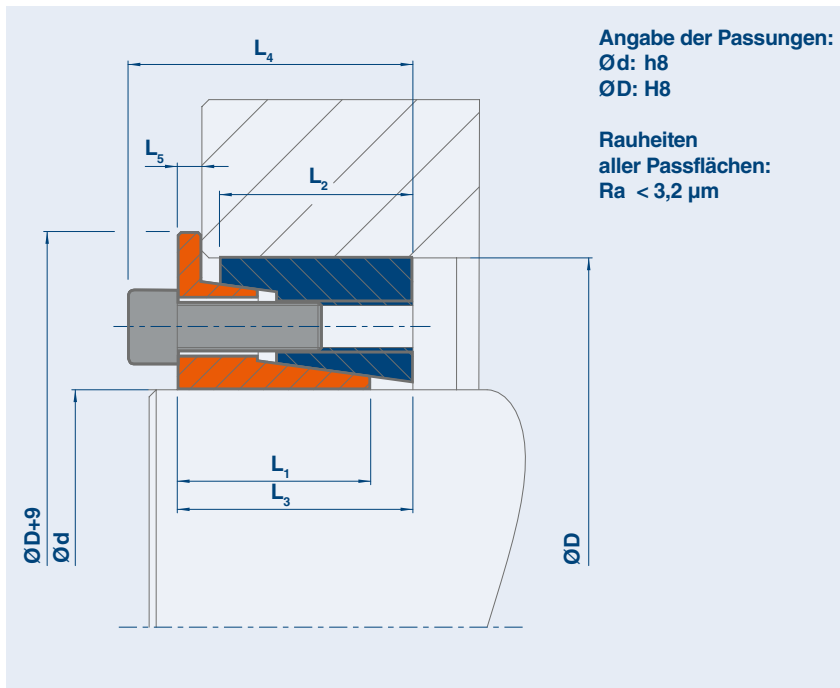

## Erläuterungen

- $M_t$  Maximal übertragbares Drehmoment eines Spannsatzes bei  $P_{ax} = 0$
- $P_{ax}$  Maximal übertragbare Axialkraft eines Spannsatzes bei  $M_t = 0$
- $M_a$  Erforderliches Anzugsmoment der Spannschrauben
- $P_w$  Flächenpressung zwischen Spannsatz und Welle
- $P_n$  Flächenpressung zw. Spannsatz und Nabe

Die Maße  $L_3$  und  $L_4$  gelten für den ungespannten Zustand.

## Innenspannsatz IS – Baureihe ISN 1

Typ	d	x	D	$M_t$ kNm	$P_{ax}$ kN	$L_1$ mm	$L_2$ mm	$L_3$ mm	$L_4$ mm	$L_5$ mm	B* Güte 12.9	$M_a$ Nm	$P_w$ N/mm <sup>2</sup>	$P_n$	kg
ISN 1	20	x	47	0,3	28	20	17	23	29	3	6 x M6	17	185	93	0,2
ISN 1	22	x	47	0,3	28	20	17	23	29	3	6 x M6	17	168	93	0,2
ISN 1	24	x	50	0,3	28	20	17	23	29	3	6 x M6	17	154	87	0,3
ISN 1	25	x	50	0,3	28	20	17	23	29	3	6 x M6	17	148	87	0,3
ISN 1	28	x	55	0,5	37	20	17	23	29	3	8 x M6	17	176	105	0,3
ISN 1	30	x	55	0,6	37	20	17	23	29	3	8 x M6	17	164	105	0,3
ISN 1	35	x	60	0,7	42	20	17	23	29	3	9 x M6	17	158	109	0,3
ISN 1	40	x	65	0,9	46	20	17	23	29	3	10 x M6	17	154	112	0,4
ISN 1	45	x	75	1,6	69	24	20	28	36	4	8 x M8	41	168	121	0,6
ISN 1	50	x	80	2,0	80	24	20	28	36	4	9 x M8	41	170	127	0,7
ISN 1	55	x	85	2,4	87	24	20	28	36	4	10 x M8	41	171	133	0,7
ISN 1	60	x	90	2,6	87	24	20	28	36	4	10 x M8	41	157	126	0,8
ISN 1	65	x	95	3,4	105	24	20	28	36	4	12 x M8	41	174	143	0,8
ISN 1	70	x	110	4,8	137	29	24	35	45	5	10 x M10	83	177	136	1,4
ISN 1	75	x	115	5,1	137	29	24	35	45	5	10 x M10	83	166	130	1,4
ISN 1	80	x	120	6,1	151	29	24	34	44	5	10 x M10	83	171	138	1,5
ISN 1	85	x	125	7,0	165	29	24	35	45	5	12 x M10	83	175	144	1,7
ISN 1	90	x	130	7,4	165	29	24	34	44	5	12 x M10	83	166	138	1,8
ISN 1	95	x	135	8,0	163	29	24	35	45	5	12 x M10	83	157	133	1,9
ISN 1	100	x	145	10	196	33	28	39	51	5	11 x M12	145	175	142	2,5
ISN 1	110	x	155	11	196	33	28	39	51	5	11 x M12	145	159	133	2,7

\*Spannschrauben DIN EN ISO 4762: Güte 12.9

Bestellangabe: (Typ x  $\varnothing d$  x  $\varnothing D$ ), z. B. ISN 1 110 x 155

## Innenspannsatz Typ IS – Baureihe ISN 1

Typ	d	x	D	M <sub>t</sub> kNm	P <sub>ax</sub> kN	L <sub>1</sub> mm	L <sub>2</sub> mm	L <sub>3</sub> mm	L <sub>4</sub> mm	L <sub>5</sub> mm	B* Güte 12.9	M <sub>a</sub> Nm	P <sub>w</sub> N/mm <sup>2</sup>	P <sub>n</sub>	kg
ISN 1	120	x	165	16	264	33	28	39	51	5	12 x M12	145	186	159	2,9
ISN 1	130	x	180	20	301	38	33	43	55	5	16 x M12	145	170	142	3,9
ISN 1	140	x	190	21	301	38	33	43	55	5	16 x M12	145	158	134	4,2
ISN 1	150	x	200	25	332	38	33	43	55	5	18 x M12	145	166	143	4,4
ISN 1	160	x	210	27	339	38	33	43	55	5	18 x M12	145	156	137	4,7
ISN 1	170	x	225	35	414	44	38	50	64	6	16 x M14	230	158	135	6,0
ISN 1	180	x	235	42	465	44	38	50	64	6	18 x M14	230	168	145	6,6
ISN 1	190	x	250	51	537	52	46	58	72	6	21 x M14	230	156	132	9,0
ISN 1	200	x	260	62	620	52	46	58	72	6	24 x M14	230	170	145	9,1
ISN 1	220	x	285	79	719	57	50	64	80	7	21 x M16	355	164	139	12
ISN 1	240	x	305	92	763	57	50	64	80	7	21 x M16	355	158	137	13
ISN 1	260	x	325	112	863	57	50	64	80	7	24 x M16	355	167	147	14
ISN 1	280	x	355	145	1039	70	60	78	96	10	24 x M18	485	159	136	21
ISN 1	300	x	375	175	1168	72	60	80	91	12	24 x M18	485	167	145	23
ISN 1	320	x	405	242	1510	87	72	95	105	15	24 x M20	690	170	144	32
ISN 1	340	x	425	257	1510	87	72	96	106	15	24 x M20	690	160	137	35
ISN 1	360	x	455	338	1879	99	84	110	122	15	24 x M22	930	156	130	47
ISN 1	380	x	475	357	1879	99	84	110	122	15	24 x M22	930	147	125	46
ISN 1	400	x	495	438	2192	99	84	110	122	15	28 x M22	930	163	140	48
ISN 1	420	x	515	493	2349	99	84	110	122	15	30 x M22	930	167	144	51
ISN 1	440	x	545	566	2573	111	96	123	137	15	30 x M24	1200	161	137	67
ISN 1	460	x	565	592	2573	111	96	123	137	15	33 x M24	1200	154	132	70
ISN 1	480	x	585	617	2571	111	96	123	137	15	33 x M24	1200	148	128	73
ISN 1	500	x	605	723	2892	111	96	123	137	15	36 x M24	1200	160	139	80

Weitere Größen auf Anfrage, technische Änderungen vorbehalten

\*Spannschrauben DIN EN ISO 4762: Güte 12.9

**Bestellangabe:** (Typ x Ød x ØD), z. B. ISN 1 200 x 260

# STÜWE® Innenspannsatz Typ IS – Baureihe IS 4

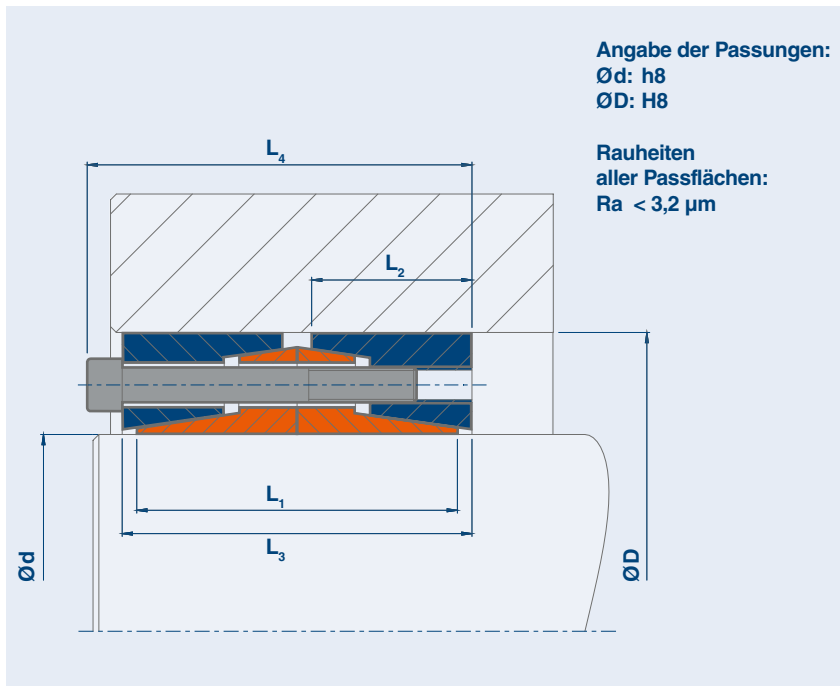

## Erläuterungen

- $M_t$  Maximal übertragbares Drehmoment eines Spannsatzes bei  $P_{ax} = 0$
- $P_{ax}$  Maximal übertragbare Axialkraft eines Spannsatzes bei  $M_t = 0$
- $M_a$  Erforderliches Anzugsmoment der Spannschrauben
- $P_w$  Flächenpressung zwischen Spannsatz und Welle
- $P_n$  Flächenpressung zw. Spannsatz und Nabe

Die Maße  $L_3$  und  $L_4$  gelten für den ungespannten Zustand.

## Innenspannsatz IS – Baureihe IS 4

Typ	d	x	D	$M_t$ kNm	$P_{ax}$ kN	$L_1$ mm	$L_2$ mm	$L_3$ mm	$L_4$ mm	B* Güte 12.9	$M_a$ Nm	$P_w$ N/mm <sup>2</sup>	$P_n$	kg
IS 4	30	x	55	0,9	60	40	17	46	52	6 x M6	17	132	85	0,5
IS 4	35	x	60	1,2	71	40	17	46	52	7 x M6	17	135	93	0,6
IS 4	40	x	65	1,5	75	40	17	46	52	8 x M6	17	125	90	0,6
IS 4	45	x	75	2,5	111	48	20	56	64	6 x M8	41	136	98	1,1
IS 4	50	x	80	3,0	120	48	20	56	64	7 x M8	41	133	100	1,1
IS 4	55	x	85	3,8	138	48	20	56	64	8 x M8	41	139	108	1,2
IS 4	60	x	90	4,3	143	48	20	56	64	8 x M8	41	132	106	1,3
IS 4	65	x	95	5,3	163	48	20	56	64	9 x M8	41	139	114	1,4
IS 4	70	x	110	7,6	217	58	24	70	80	8 x M10	83	142	109	2,6
IS 4	75	x	115	8,2	219	58	24	70	80	8 x M10	83	133	105	2,7
IS 4	80	x	120	8,7	217	58	24	70	80	8 x M10	83	124	100	2,8
IS 4	85	x	125	10,4	245	58	24	70	80	9 x M10	83	132	108	3,0
IS 4	90	x	130	12	272	58	24	70	80	10 x M10	83	138	116	3,1
IS 4	95	x	135	13	271	58	24	70	80	10 x M10	83	131	111	3,3
IS 4	100	x	145	16	317	66	28	76	88	8 x M12	145	127	104	4,5
IS 4	110	x	155	19	340	66	28	78	90	9 x M12	145	124	104	4,8
IS 4	120	x	165	23	377	66	28	78	90	10 x M12	145	126	108	5,2
IS 4	130	x	180	29	453	76	33	86	98	12 x M12	145	122	101	7,2
IS 4	140	x	190	32	453	76	33	86	98	12 x M12	145	113	96	7,7
IS 4	150	x	200	40	528	76	33	86	98	14 x M12	145	123	106	8,2
IS 4	160	x	210	45	566	76	33	86	98	15 x M12	145	123	108	8,6

\*Spannschrauben DIN EN ISO 4762: Güte 12.9  
**Bestellangabe:** (Typ x  $\text{Ø}d$  x  $\text{Ø}D$ ), z. B. IS 4 x 100 x 145



## Innenspannsatz Typ IS – Baureihe IS 4

Typ	d	x	D	M <sub>t</sub> kNm	P <sub>ax</sub> kN	L <sub>1</sub> mm	L <sub>2</sub> mm	L <sub>3</sub> mm	L <sub>4</sub> mm	B* Güte 12.9	M <sub>a</sub> Nm	P <sub>w</sub> N/mm <sup>2</sup>	P <sub>n</sub>	kg
IS 4	170	x	225	53	622	86	38	98	112	12 x M14	230	113	96	11
IS 4	180	x	235	65	726	86	38	98	112	14 x M14	230	124	108	12
IS 4	190	x	250	79	829	102	46	114	128	16 x M14	230	114	96	17
IS 4	200	x	260	93	933	102	46	114	128	18 x M14	230	121	103	17
IS 4	220	x	285	126	1141	110	50	124	140	16 x M16	355	125	106	22
IS 4	240	x	305	137	1141	110	50	124	140	16 x M16	355	115	99	24
IS 4	260	x	325	167	1284	110	50	124	140	18 x M16	355	119	106	26
IS 4	280	x	355	219	1562	130	60	146	164	18 x M18	485	114	97	38
IS 4	300	x	375	260	1735	130	60	146	164	18 x M18	485	118	102	40
IS 4	320	x	405	357	2230	154	72	172	192	18 x M20	690	120	101	58
IS 4	340	x	425	379	2230	154	72	176	196	20 x M20	690	113	97	62
IS 4	360	x	455	501	2784	178	84	200	222	18 x M22	930	115	97	85
IS 4	380	x	475	555	2923	178	84	198	220	20 x M22	930	115	97	89
IS 4	400	x	495	585	2923	178	84	198	220	20 x M22	930	109	93	93
IS 4	420	x	515	658	3132	178	84	200	222	22 x M22	930	111	96	97
IS 4	440	x	545	796	3616	202	96	220	244	22 x M24	1200	108	92	128
IS 4	460	x	565	832	3616	202	96	226	250	22 x M24	1200	103	88	134
IS 4	480	x	585	868	3616	202	96	228	252	24 x M24	1200	99	85	139
IS 4	500	x	605	984	3938	202	96	226	250	26 x M24	1200	103	90	144
IS 4	520	x	630	1024	3938	202	96	226	250	25 x M24	1200	99	86	157
IS 4	540	x	650	1063	3938	202	96	226	250	26 x M24	1200	96	84	162
IS 4	560	x	670	1181	4219	202	96	226	250	27 x M24	1200	99	87	168
IS 4	580	x	690	1224	4219	202	96	226	250	27 x M24	1200	96	84	173
IS 4	600	x	710	1266	4219	202	96	226	250	27 x M24	1200	92	82	179

Weitere Größen auf Anfrage, technische Änderungen vorbehalten

\*Spannschrauben DIN EN ISO 4762: Güte 12.9

**Bestellangabe:** (Typ x Ød x ØD), z. B. IS 4 200 x 260

# STÜWE® Innenspannsatz Typ IS – Baureihe IS 4.1

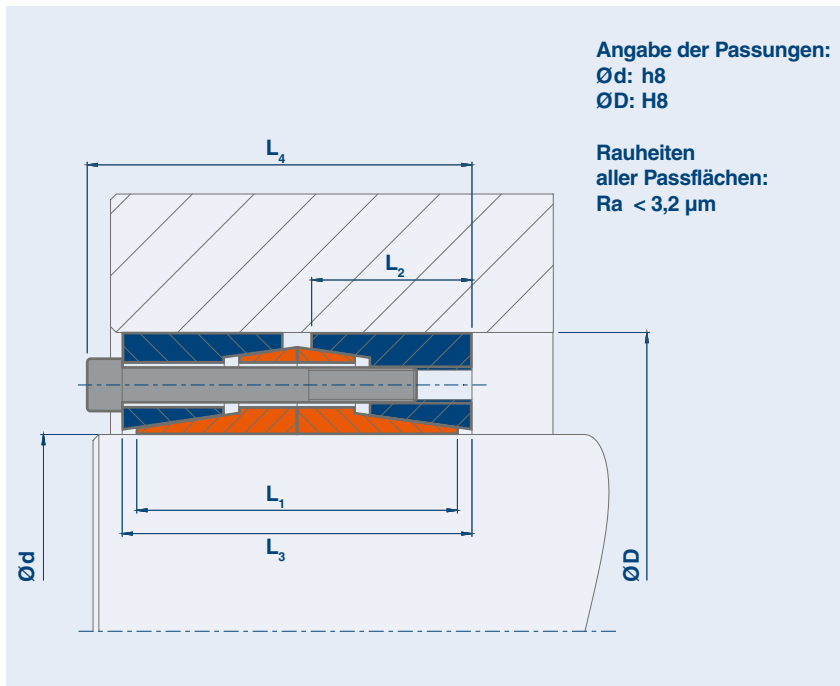

## Erläuterungen

- $M_t$  Maximal übertragbares Drehmoment eines Spannsatzes bei  $P_{ax} = 0$
- $P_{ax}$  Maximal übertragbare Axialkraft eines Spannsatzes bei  $M_t = 0$
- $M_a$  Erforderliches Anzugsmoment der Spannschrauben
- $P_w$  Flächenpressung zwischen Spannsatz und Welle
- $P_n$  Flächenpressung zw. Spannsatz und Nabe

Die Maße  $L_3$  und  $L_4$  gelten für den ungespannten Zustand.

## Innenspannsatz IS – Baureihe IS 4.1

Typ	d	x	D	$M_t$ kNm	$P_{ax}$ kN	$L_1$ mm	$L_2$ mm	$L_3$ mm	$L_4$ mm	B* Güte 12.9	$M_a$ Nm	$P_w$ N/mm <sup>2</sup>	$P_n$	kg
IS 4.1	100	x	145	11	224	66	28	76	86	8 x M10	83	90	73	4
IS 4.1	110	x	155	13	240	66	28	78	88	9 x M10	83	88	73	5
IS 4.1	120	x	165	16	267	66	28	78	88	10 x M10	83	89	77	5
IS 4.1	130	x	180	20	312	76	33	86	96	12 x M10	83	84	70	7
IS 4.1	140	x	190	22	320	76	33	86	96	12 x M10	83	80	68	8
IS 4.1	150	x	200	27	364	76	33	86	96	14 x M10	83	85	73	8
IS 4.1	160	x	210	31	390	76	33	86	96	15 x M10	83	85	75	9
IS 4.1	170	x	225	38	449	86	38	98	110	12 x M12	145	82	70	11
IS 4.1	180	x	235	47	524	86	38	98	110	14 x M12	145	90	78	12
IS 4.1	190	x	250	57	599	102	46	114	126	16 x M12	145	82	69	17
IS 4.1	200	x	260	67	674	102	46	114	126	18 x M12	145	88	75	17
IS 4.1	220	x	285	91	828	110	50	124	138	16 x M14	230	91	77	22
IS 4.1	240	x	305	99	822	110	50	124	138	16 x M14	230	83	72	24
IS 4.1	260	x	325	122	937	110	50	124	138	18 x M14	230	87	76	26
IS 4.1	280	x	355	181	1294	130	60	146	162	18 x M16	355	94	81	38
IS 4.1	300	x	375	215	1431	130	60	146	162	20 x M16	355	97	84	40
IS 4.1	320	x	405	276	1725	154	72	172	190	18 x M18	485	93	78	58
IS 4.1	340	x	425	294	1732	154	72	176	194	20 x M18	485	88	75	62
IS 4.1	360	x	455	372	2065	178	84	200	218	22 x M18	485	85	72	85
IS 4.1	380	x	475	393	2068	178	84	198	216	22 x M18	485	81	69	89
IS 4.1	400	x	495	414	2068	178	84	198	216	24 x M18	485	77	66	93

\*Spannschrauben DIN EN ISO 4762: Güte 12.9  
 Bestellangabe: (Typ x  $\text{Ø}d$  x  $\text{Ø}D$ ) z. B. IS 4.1 170 x 225

## Innenspannsatz IS – Baureihe IS 4.1

Typ	d	x	D	M <sub>t</sub> kNm	P <sub>ax</sub> kN	L <sub>1</sub> mm	L <sub>2</sub> mm	L <sub>3</sub> mm	L <sub>4</sub> mm	B* Güte 12.9	M <sub>a</sub> Nm	P <sub>w</sub> N/mm <sup>2</sup>	P <sub>n</sub>	kg
IS 4.1	420	x	515	507	2412	178	84	200	218	26 x M18	485	86	74	97
IS 4.1	440	x	545	530	2409	202	96	228	248	24 x M20	690	72	61	128
IS 4.1	460	x	565	554	2409	202	96	226	246	22 x M20	690	69	59	134
IS 4.1	480	x	585	578	2409	202	96	228	248	24 x M20	690	66	57	139
IS 4.1	500	x	605	703	2811	202	96	226	246	26 x M20	690	74	64	144
IS 4.1	520	x	630	731	2811	202	96	226	246	26 x M20	690	71	62	157
IS 4.1	540	x	650	759	2811	202	96	226	246	26 x M20	690	68	60	162
IS 4.1	560	x	670	843	3012	202	96	226	246	30 x M20	690	71	62	168
IS 4.1	580	x	690	873	3012	202	96	226	246	30 x M20	690	68	60	173
IS 4.1	600	x	710	903	3012	202	96	226	246	30 x M20	690	66	59	179

Weitere Größen auf Anfrage, technische Änderungen vorbehalten

\*Spannschrauben DIN EN ISO 4762: Güte 12.9

**Bestellangabe:** (Typ x Ød x ØD) z. B. IS 4.1 420 x 515

**STÜWE**®

**STÜWE® GmbH & Co. KG**

Zum Ludwigstal 35 - 45527 Hattingen

Tel. +49 2324 394-0 - Fax +49 2324 394-30

[www.stuewe.de](http://www.stuewe.de) - [info@stuewe.de](mailto:info@stuewe.de)

Informationen zu unseren Vertretungen weltweit finden Sie unter [www.stuewe.de/kontakt](http://www.stuewe.de/kontakt)