



STÜWE[®]

Produktkatalog Schrumpfscheibe TYP HYD



Zertifiziert nach
DIN ISO 9001:2008

STÜWE[®]

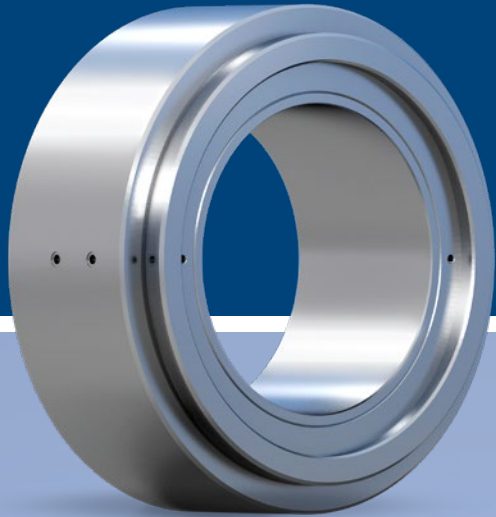

SCHRUMPFSCHEIBE TYP HYD



SCHRUMPFSCHEIBE TYP HYD – ALLGEMEINES

Anwendungsbeschreibung

Die hydraulische Schrumpfscheibe Typ HYD basiert auf dem gleichen Prinzip wie die mechanische Schrumpfscheibe Typ HSD. Auf Grund der hydraulischen Verspannung wird im Vergleich zum mechanischen Typ HSD nur ein Bruchteil der Zeit zum Verspannen benötigt.

Einsatzgebiete

Baureihe	Wellendurchmesser	Übertragbare Drehmomente
HYD 12	90 - 680 mm	16 - 6211 kNm
HYD 22	50 - 860 mm	2,7 - 12349 kNm

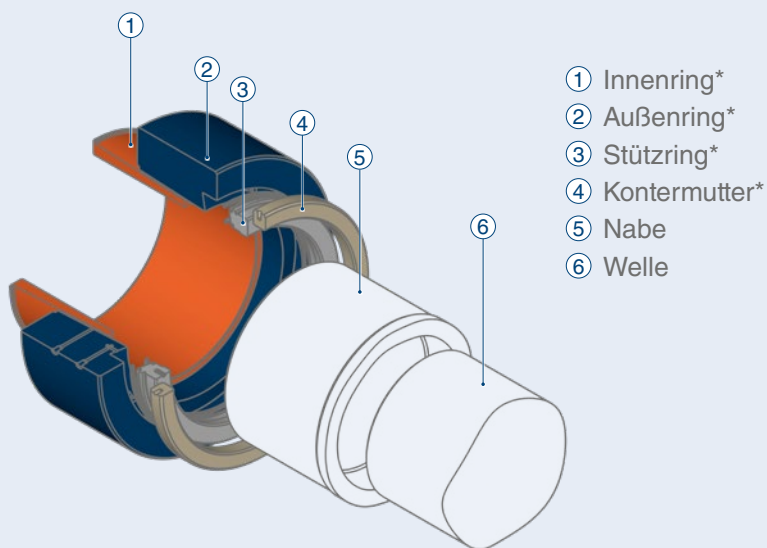

*Im Lieferumfang enthalten

STÜWE® Schrumpfscheibe Typ HYD

Baureihe 12

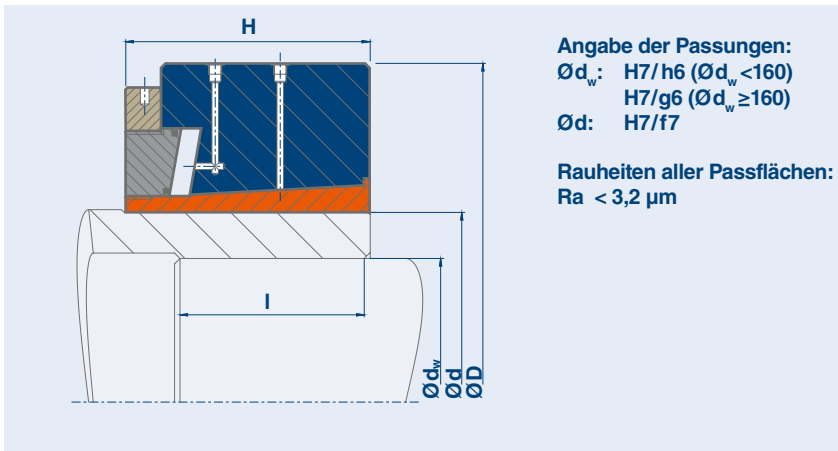

Erläuterungen

- M_t** Maximal übertragbares Drehmoment einer Schrumpfscheibe bei $P_{ax} = 0$
- P_{ax}** Maximal übertragbare Axialkraft einer Schrumpfscheibe bei $M_t = 0$
- HP** Hochdruck beträgt maximal 3800 bar
- T** Spanndruck beträgt maximal 450 bar

Schrumpfscheibe Typ HYD – Baureihe 12

Typ	d mm	d_w mm	M_t kNm	P_{ax} kN	D mm	l mm	H mm	kg
HYD 125 - 12		90	16	348	215	42	75	13
		95	18	377				
		100	20	406				
HYD 140 - 12	140	100	19	374	245	46	84	20
		105	21	401				
		110	24	429				
HYD 155 - 12	155	110	27	488	263	50	90	23
		115	30	520				
		120	33	551				
HYD 165 - 12	165	120	36	592	290	56	90	29
		125	39	628				
		130	43	663				
HYD 175 - 12	175	130	50	776	300	71	90	31
		135	55	818				
		140	60	861				
HYD 185 - 12	185	140	62	881	320	71	117	46
		145	67	924				
		150	73	968				
HYD 200 - 12	200	150	73	976	340	71	117	51
		160	85	1064				
		165	91	1108				
HYD 220 - 12	220	160	96	1194	370	80	130	66
		170	110	1297				
		180	126	1401				
HYD 240 - 12	240	180	140	1560	430	86	150	110
		190	159	1677				
		200	180	1796				
HYD 260 - 12	260	200	180	1795	430	95	145	98
		210	201	1916				
		220	224	2038				
HYD 280 - 12	280	220	228	2073	460	100	150	115
		230	253	2198				
		240	279	2323				

Bestellangabe: (Typ x $\varnothing d$), z. B. HYD 155 - 12 x 155

Schrumpfscheibe Typ HYD – Baureihe 12

Typ	d mm	d _w mm	M _t kNm	P _{ax} kN	max. hyd. Druck bar	D mm	l mm	H mm	kg
HYD 300 - 12	300	230	258	2242	450	485	110	160	134
		240	285	2371					
		250	313	2501					
HYD 320 - 12	320	250	348	2781	450	520	120	179	173
		260	381	2929					
		270	415	3077					
HYD 340 - 12	340	260	398	3063	450	570	120	179	216
		270	434	3215					
		280	472	3369					
HYD 360 - 12	360	280	467	3334	450	590	120	179	225
	350	290	505	3486					
	300	300	546	3638					
HYD 390 - 12	390	310	617	3978	450	650	135	200	311
	380	320	663	4143					
	330	330	711	4308					
HYD 420 - 12	420	330	718	4353	450	690	135	200	345
		340	768	4519					
		350	820	4686					
HYD 440 - 12	440	340	836	4917	450	720	160	240	449
		350	893	5100					
		360	951	5284					
HYD 460 - 12	460	360	944	5246	450	745	160	240	475
		370	1004	5429					
		380	1066	5612					
HYD 480 - 12	480	380	1221	6425	450	780	170	260	566
		390	1293	6631					
		400	1368	6839					
HYD 500 - 12	500	400	1335	6674	450	830	170	260	657
		410	1411	6881					
		420	1488	7088					
HYD 530 - 12	530	430	1524	7088	450	850	190	280	712
		440	1605	7294					
		450	1688	7501					
HYD 560 - 12	560	450	1673	7435	450	880	190	280	743
		460	1757	7640					
		470	1844	7846					
HYD 590 - 12	590	470	1987	8456	450	940	200	300	925
		480	2082	8676					
		490	2179	8896					
HYD 620 - 12	620	500	2236	8945	450	965	210	310	976
		510	2337	9166					
		520	2441	9389					
HYD 660 - 12	660	530	2728	10294	450	1040	210	310	1153
		540	2843	10529					
		550	2960	10764					
HYD 700 - 12	700	560	3278	11708	450	1100	220	320	1327
		580	3540	12207					
		600	3812	12708					
HYD 750 - 12	750	600	4555	15184	450	1260	240	350	2066
		620	4889	15772					
		640	5236	16361					
HYD 800 - 12	800	640	5446	17019	450	1310	260	370	2293
		660	5822	17642					
		680	6211	18267					

Weitere Größen auf Anfrage, technische Änderungen vorbehalten

Bestellangabe: (Typ x Ød), z. B. HYD 560 - 12 x 560

STÜWE® Schrumpfscheibe Typ HYD

Baureihe 22

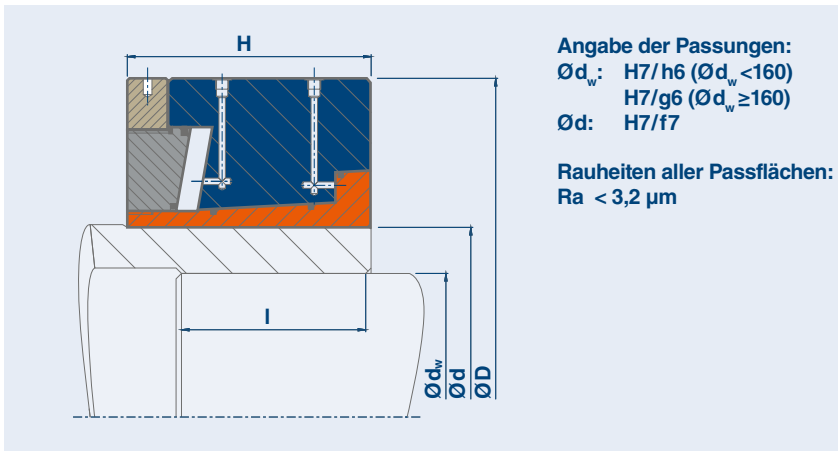

Erläuterungen

- M_t Maximal übertragbares Drehmoment einer Schrumpfscheibe bei $P_{ax} = 0$
- P_{ax} Maximal übertragbare Axialkraft einer Schrumpfscheibe bei $M_t = 0$

Schrumpfscheibe Typ HYD – Baureihe 22

Typ	d mm	d _w mm	M _t kNm	P _{ax} kN	max. hyd. Druck bar	D mm	l mm	H mm	kg
HYD 62 - 22		50	2,7	107	450	130	33	60	5
		52	3,0	114					
		53	3,1	118					
HYD 80 - 22	80	55	3,1	112	450	155	33	60	6
		60	3,9	130					
		65	4,8	148					
HYD 100 - 22	100	70	7,6	217	450	185	45	70	10
		75	9,0	241					
		80	10,6	265					
HYD 125 - 22	125	90	18	390	450	230	45	75	16
		95	20	421					
		100	23	453					
HYD 140 - 22	140	100	25	495	450	263	50	84	24
		105	28	529					
		110	31	563					
HYD 155 - 22	155 150	110	33	592	450	300	50	90	34
		115	36	628					
		120	40	663					
HYD 165 - 22	165	120	40	667	450	320	53	102	44
		125	44	706					
		130	48	744					
HYD 175 - 22	175	130	50	770	450	320	53	102	42
		135	55	810					
		140	59	850					
HYD 185 - 22	185	140	74	1056	450	340	71	117	55
		145	80	1106					
		150	87	1155					
HYD 200 - 22	200	150	86	1151	450	370	71	117	65
		160	100	1249					
		165	107	1299					
HYD 220 - 22	220	160	105	1311	450	405	88	140	93
		170	121	1425					
		180	139	1540					

Bestellangabe: (Typ x Ød), z. B. HYD 155 - 22 x 150

Schrumpfscheibe Typ HYD – Baureihe 22

Typ	d mm	d _w mm	M _t kNm	P _{ax} kN	max. hyd. Druck bar	D mm	l mm	H mm	kg
HYD 240 - 22	240	180	145	1615	450	430	88	143	105
		190	165	1737					
		200	186	1861					
HYD 260 - 22	260	200	199	1988	450	460	100	160	142
		210	223	2123					
		220	249	2259					
HYD 280 - 22	280	220	285	2587	450	485	122	180	174
		230	315	2741					
		240	348	2896					
HYD 300 - 22	300	230	326	2833	450	520	120	190	198
		240	359	2991					
		250	394	3149					
HYD 320 - 22	320	250	397	3175	450	570	140	220	285
		260	434	3342					
		270	474	3510					
HYD 340 - 22	340	260	541	4162	450	640	140	220	374
		270	589	4363					
		280	639	4565					
HYD 360 - 22	360	280	646	4615	450	660	140	220	388
		350	699	4815					
		300	753	5022					
HYD 390 - 22	390	310	791	5101	450	690	140	220	412
		380	849	5304					
		330	909	5508					
HYD 420 - 22	420	330	850	5152	450	720	178	255	506
		340	910	5352					
		350	972	5552					
HYD 440 - 22	440	340	915	5384	450	740	168	255	530
		350	977	5584					
		360	1041	5785					
HYD 460 - 22	460	360	1016	5645	450	760	165	255	540
		370	1081	5842					
		380	1147	6039					
HYD 480 - 22	480	380	1386	7293	450	830	188	295	785
		390	1468	7526					
		400	1552	7760					
HYD 500 - 22	500	400	1720	8600	450	850	188	295	810
		410	1816	8859					
		420	1915	9118					
HYD 530 - 22	530	430	2141	9958	450	910	223	330	1045
		440	2252	10236					
		450	2366	10515					
HYD 560 - 22	560	450	2397	10653	450	980	223	330	1240
		460	2515	10934					
		470	2636	11216					
HYD 590 - 22	590	470	2726	11600	450	1020	230	360	1445
		480	2854	11892					
		490	2985	12185					
HYD 620 - 22	620	500	3203	12810	450	1070	230	360	1595
		510	3345	13119					
		520	3491	13428					
HYD 660 - 22	660	530	4079	15393	450	1160	245	380	2005
		540	4248	15734					
		550	4421	16076					
HYD 700 - 22	700	560	4501	16073	450	1210	260	420	2345
		580	4857	16749					
		600	5228	17428					

Bestellangabe: (Typ x Ød), z. B. HYD 390 - 22 x 380

Schrumpfscheibe Typ HYD – Baureihe 22

Typ	d mm	d _w mm	M _t kNm	P _{ax} kN	max. hyd. Druck bar	D mm	l mm	H mm	kg
HYD 750 - 22	750	580	4808	16579	450	1260	300	450	2705
		590	4990	16916					
		600	5176	17255					
HYD 775 - 22	775	610	5521	18101	450	1350	320	490	3300
		620	5719	18449					
		630	5921	18798					
HYD 800 - 22	800	640	6108	19088	450	1310	340	480	2974
		660	6536	19805					
		680	6978	20524					
HYD 850 - 22	850	680	7542	22183	450	1430	340	520	3895
		690	7786	22568					
		700	8033	22953					
HYD 900 - 22	900	700	8443	24123	450	1520	360	550	4752
		710	8707	24526					
		730	9247	25334					
HYD 950 - 22	950	740	10034	27119	450	1590	380	580	5429
		750	10329	27544					
		800	11871	29677					
HYD 1000 - 22	1000	820	12680	30927	450	1650	400	600	5951
		830	13018	31369					
		850	13708	32254					
HYD 1025 - 22	1025	840	13603	32388	450	1700	410	620	6567
		850	13956	32838					
		860	14314	33288					

Weitere Größen auf Anfrage, technische Änderungen vorbehalten

Bestellangabe: (Typ x Ød), z. B. HYD 900 - 22 x 900



STÜWE®

STÜWE® GmbH & Co. KG

Zum Ludwigstal 35 - 45527 Hattingen

Tel. +49 2324 394-0 - Fax +49 2324 394-30

www.stuewe.de - info@stuewe.de

Informationen zu unseren Vertretungen weltweit finden Sie unter www.stuewe.de/kontakt